

# Proposed Rules

Federal Register

Vol. 80, No. 216

Monday, November 9, 2015

This section of the FEDERAL REGISTER contains notices to the public of the proposed issuance of rules and regulations. The purpose of these notices is to give interested persons an opportunity to participate in the rule making prior to the adoption of the final rules.

## CONSUMER PRODUCT SAFETY COMMISSION

### 16 CFR Parts 1112 and 1231

[Docket No. CPSC-2015-0031]

#### Safety Standard for High Chairs

**AGENCY:** Consumer Product Safety Commission.

**ACTION:** Notice of proposed rulemaking.

**SUMMARY:** The Danny Keysar Child Product Safety Notification Act, section 104(b) of the Consumer Product Safety Improvement Act of 2008 (“CPSIA”; Pub. L. 110-314, 122 Stat. 3016), requires the United States Consumer Product Safety Commission (“Commission” or “CPSC”) to promulgate consumer product safety standards for durable infant or toddler products. These standards must be substantially the same as applicable voluntary standards or more stringent than the voluntary standard if the Commission determines that more stringent requirements would further reduce the risk of injury associated with a product. In response to the direction under section 104(b) of the CPSIA, the Commission is proposing a safety standard for high chairs. The proposed rule would incorporate by reference ASTM F404-15, *Standard Consumer Safety Specification for High Chairs* (“ASTM F404-15”) into our new regulation and impose more stringent requirements for rearward stability and warnings on labels and in instructional literature. In addition, the Commission proposes to amend our regulations to include the newly proposed high chair standard in the list of notice of requirements (“NORs”) issued by the Commission.

**DATES:** Submit comments by January 25, 2016.

**ADDRESSES:** Comments related to the Paperwork Reduction Act aspects of the labeling and instructional literature requirements of the proposed mandatory standard for high chairs should be directed to the Office of

Information and Regulatory Affairs, the Office of Management and Budget, Attn: CPSC Desk Officer, FAX: 202-395-6974, or emailed to [oira\\_submission@omb.eop.gov](mailto:oira_submission@omb.eop.gov).

Other comments, identified by Docket No. CPSC-2015-0031, may be submitted electronically or in writing:

**Electronic Submissions:** Submit electronic comments to the Federal eRulemaking Portal at: <http://www.regulations.gov>. Follow the instructions for submitting comments. The Commission does not accept comments submitted by electronic mail (email), except through [www.regulations.gov](http://www.regulations.gov). The Commission encourages you to submit electronic comments by using the Federal eRulemaking Portal, as described above.

**Written Submissions:** Submit written comments by mail/hand delivery/courier to: Office of the Secretary, Consumer Product Safety Commission, Room 820, 4330 East West Highway, Bethesda, MD 20814; telephone (301) 504-7923.

**Instructions:** All submissions received must include the agency name and docket number for this proposed rulemaking. All comments received may be posted without change, including any personal identifiers, contact information, or other personal information provided, to: <http://www.regulations.gov>. Do not submit confidential business information, trade secret information, or other sensitive or protected information that you do not want to be available to the public. If furnished at all, such information should be submitted by mail/hand delivery/courier.

**Docket:** For access to the docket to read background documents or comments received, go to: <http://www.regulations.gov>, and insert the docket number, CPSC-2015-0031, into the “Search” box, and follow the prompts.

**FOR FURTHER INFORMATION CONTACT:** Stefanie C. Marques, Project Manager, Directorate for Health Sciences, U.S. Consumer Product Safety Commission, 5 Research Place, Rockville, MD 20850; telephone: 301-987-2581; email: [smarques@cpsc.gov](mailto:smarques@cpsc.gov).

#### SUPPLEMENTARY INFORMATION:

##### I. Background and Statutory Authority

The CPSIA was enacted on August 14, 2008. Section 104(b) of the CPSIA, part

of the Danny Keysar Child Product Safety Notification Act, requires the Commission to: (1) examine and assess the effectiveness of voluntary consumer product safety standards for durable infant or toddler products, in consultation with representatives of consumer groups, juvenile product manufacturers, and independent child product engineers and experts; and (2) promulgate consumer product safety standards for durable infant or toddler products. Any standard the Commission adopts under this directive must be substantially the same as the applicable voluntary standard or more stringent than the voluntary standard if the Commission determines that more stringent requirements would further reduce the risk of injury associated with the product.

The term “durable infant or toddler product” is defined in section 104(f)(1) of the CPSIA as “a durable product intended for use, or that may be reasonably expected to be used, by children under the age of 5 years.” Section 104(f)(2)(C) of the CPSIA specifically identifies high chairs as a durable infant or toddler product.

Pursuant to section 104(b)(1)(A) of the CPSIA, the Commission consulted with representatives of manufacturers, consumer groups, consultants, retailers, industry trade groups, and government agencies in reviewing and assessing the effectiveness of the existing voluntary standard for high chairs, ASTM F404-15, largely through ASTM International’s (“ASTM”; formerly the American Society for Testing and Materials) standard-development process. The standard the Commission is proposing in this notice of proposed rulemaking (“NPR”) is based on ASTM F404-15 with more stringent requirements for rearward stability and warnings in labels and instructional literature.

The testing and certification requirements of section 14(a) of the Consumer Product Safety Act (“CPSA”; 15 U.S.C. 2051-2089) apply to the standards promulgated under section 104 of the CPSIA. Section 14(a)(3) of the CPSA requires the Commission to publish an NOR for the accreditation of third party conformity assessment bodies (*i.e.*, test laboratories) to assess whether a children’s product conforms to applicable children’s product safety rules. If adopted, the proposed rule for

high chairs would be a children’s product safety rule that requires the issuance of an NOR. For this reason, this NPR also proposes to amend 16 CFR part 1112 to include proposed 16 CFR part 1231, the section in which the high chair standard would be codified.

**II. The Product**

*A. Definition*

ASTM F404–15 defines a “high chair” as “a free standing chair for a child up to 3 years of age which has a seating surface more than 15 in. above the floor and elevates the child normally for the purposes of feeding or eating.” The ASTM standard further specifies that a high chair may be sold with or without a tray, have adjustable heights, and recline for infants.

There are various designs and construction materials for high chairs. Typical high chairs consist of a plastic, wood, or metal frame, often with a padded fabric seat. Some models fold for storage and transport or convert for continued use as a child grows. Some high chairs include a removable snack tray or mounted toy accessories and some have no trays. High chairs may have a passive crotch restraint (*i.e.*, two separate bounded openings for the occupant’s legs), a rigid front torso support, a three-point restraint system, or a five-point restraint system with

shoulder harnesses. High chair designs include restaurant-style chairs, four-legged A-frame styles, single-leg pedestals, and Z-frame styles. Restaurant-style high chairs are discussed further in section VII. of this preamble.

*B. Market Description*

In 2013, the CPSC conducted a Durable Nursery Product Exposure Survey (“DNPES”) of U.S. households with children under the age of 6. Data from DNPES indicate that there are approximately 9.74 million high chairs in U.S. households with children under the age of 6 and about 7.14 million high chairs actually in use in those households. High chairs range in price from \$35 to \$650.

Staff identified 62 firms supplying high chairs to the U.S. market. Fifty-one of these are domestic, including 27 manufacturers, 19 importers, and five wholesalers. The remaining 11 firms are foreign, including nine manufacturers, one importer, and one retailer. Of these 62 firms, 48 market their high chairs to consumers. The remaining 14 firms market their high chairs for use in commercial settings, primarily in restaurants, but these products generally also are available to consumers.

**III. Incident Data**

The Commission receives data regarding product-related injuries from several sources. One such source is the National Electronic Injury Surveillance System (“NEISS”), from which CPSC can estimate the number of injuries associated with specific consumer products that are treated in U.S. hospital emergency departments (“EDs”) nationwide, based on a probability sample. Other sources include reports from consumers and others through the Consumer Product Safety Risk Management System (which also includes some NEISS data) and reports from retailers and manufacturers through CPSC’s Retailer Reporting System (collectively referred to as Consumer Product Safety Risk Management System data (“CPSRMS”).

Through CPSRMS sources, the Commission has received 1,296 reports of incidents related to high chairs that occurred between January 1, 2011 and December 31, 2014. Because several of these reports include more than one incident or issue, the total number of incidents is 1,308. These reports include one fatality and 138 injuries; for the remaining incidents, no injury occurred, or no injury was reported. Table 1 provides the number of incidents, injuries, and fatalities by year for 2011 to 2014.

TABLE 1—CPSRMS INCIDENT REPORTS INVOLVING HIGH CHAIRS BETWEEN JANUARY 1, 2011 AND DECEMBER 31, 2014

Incident year	Total	Injuries	Fatalities
2011 .....	276	44	0
2012* .....	360	51	0
2013* .....	491	28	0
2014* .....	169	15	1
<b>Total .....</b>	<b>1,296</b>	<b>138</b>	<b>1</b>

Source: CPSC’s Consumer Product Safety Risk Management System  
 \* data collection is ongoing

Of the 1,296 reports CPSC received from CPSRMS sources, 923 provided the age of the child involved. For incidents in which age was reported, the majority involved children between 7 and 18 months old.

EDs participating in NEISS reported 1,078 injuries and no deaths related to high chairs between January 1, 2011 and December 31, 2014. Extrapolating from this probability sample, there were approximately 31,300 injuries and no fatalities related to high chairs treated in EDs between January 1, 2011 and December 31, 2014. Approximately 75 percent of injuries reported through NEISS involved children between 7 and 23 months old.

*A. Fatalities*

The Commission received a report in 2014 of one fatality associated with a high chair. Apart from indicating that the high chair involved had broken, the report provided little information about the decedent or the circumstances of the incident. The Commission has been unable to obtain additional information regarding this incident.

*B. Nonfatal Injuries*

Of the 138 CPSRMS injuries related to high chairs that occurred between 2011 and 2014, three resulted in moderate injuries treated in EDs. These injuries included a puncture wound to the forehead, a broken collarbone, and a

lacerated finger. There were no severe injuries, and the remaining injuries primarily resulted in contusions, abrasions, and lacerations. Many of the incident descriptions in the remaining 1,157 reports that did not state that an injury had occurred, nevertheless, indicated the potential for injury.

For injuries reported through NEISS, 94 percent were treated and released. The most commonly injured body parts were the head (65 percent) and face (17 percent). The most common types of injuries were injuries to internal organs (48 percent), contusions and abrasions (22 percent), and lacerations (11 percent). In 1,540 of the estimated 31,300 injuries treated in U.S. EDs,

severe head injuries, such as fractured skulls and concussions, occurred.

*C. Hazard Pattern Identification*

CPSC staff reviewed NEISS and CPSRMS data to identify hazard patterns associated with high chairs. Because CPSRMS data sources generally provide greater detail about incidents, staff was able to identify more distinct hazard patterns using this data than NEISS data. CPSC staff identified

several hazard patterns associated with high chairs in reviewing the 1,308 CPSRMS incidents. Approximately 96 percent of the 1,308 incidents involved issues with specific components of the high chair, including the frame, seat, restraint system, armrest, tray, toy accessories, wheels, footrest, and other features. Approximately 4 percent involved general problems with the high chair, including the design and stability,

and less than 1 percent fell into other categories, including consumer observations and incidents in which reports provided insufficient information to identify a hazard pattern (*i.e.*, undetermined). Staff was unable to identify the hazard pattern for the one fatality because there was insufficient information in the report. Table 2 provides the frequency of each hazard pattern and category.

TABLE 2—HAZARD PATTERNS FOR CPSRMS INCIDENTS INVOLVING HIGH CHAIRS BETWEEN JANUARY 1, 2011 AND DECEMBER 31, 2014

Hazard pattern	Total incidents	Injuries	Fatalities
Frame .....	650	20	0
Seat .....	205	41	0
Restraint System .....	139	12	0
Armrest .....	81	2	0
Tray .....	75	33	0
Toy Accessories .....	70	1	0
Wheels .....	21	1	0
Footrest .....	14	0	0
Miscellaneous Issues .....	8	1	0
Design .....	22	13	0
Stability .....	16	12	0
Consumer Observations .....	3	0	0
Undetermined .....	4	2	1
<b>Total .....</b>	<b>1,308</b>	<b>138</b>	<b>1</b>

Issues with frames account for the greatest number of incidents. Examples of these incidents include broken frames, legs, seat supports, and loose screws. Issues with seats are associated with the greatest number of injuries. Examples of these incidents include torn, cracked, or peeling seat pads and seat-reclining issues. Examples of restraint system incidents include broken buckles and prongs, jamming, easy release, torn or fraying straps, pinching, and ineffective restraints. Examples of issues with armrests include cracking or breaking. Examples of tray incidents include trays failing to lock or remain locked, trays releasing too easily, difficulty releasing trays, and pinching. Examples of toy accessory incidents include cracked or broken toy accessories. Examples of incidents involving wheels include broken or loose wheels or wheels not locking. Examples of footrest incidents include cracked or broken footrests. Examples of other miscellaneous issues include unclear assembly instructions, excessive lead content in paint, finish coming off, poor construction quality, and loose hardware.

General issues with the design and stability of high chairs also contributed to incidents and injuries. Examples of incidents related to design issues include children’s limbs, fingers, and

toes becoming entrapped in spaces or openings. In two separate incidents, children were entrapped by the neck in the seatback opening and leg opening of high chairs. Examples of incidents involving stability issues include a high chair actually or nearly tipping over.

CPSC identified two additional categories that do not represent particular hazard patterns. First, several incident reports included consumer observations that did not indicate an incident with a high chair had occurred. Examples of these include perceived safety hazards and unauthorized sales of recalled high chairs. Second, several reports, including a fatality report, provided insufficient information for CPSC to determine the circumstances or cause of the incident.

One issue that relates to several of these hazard patterns is prevalent in both NEISS and CPSRMS incidents—namely, falls from high chairs. Many of the incidents reported through NEISS and CPSRMS sources involved children falling from high chairs. Within NEISS data, 78 percent of incidents involved falls but did not specify the cause, and an additional 18 percent involved mainly falls that occurred when a component of a high chair failed, a high chair tipped over, or a child climbed in or out of a high chair. Many of the CPSRMS incidents also involved falls

from a high chair. Fall incidents are particularly evident in the stability, restraint system, tray, and frame hazard patterns. Falls often occurred when these features fail or the restraint system is not used properly. Fall incidents have the potential to result in serious injuries, including severe head injuries, which can cause brain damage and impact a child’s development and cognitive skills. Of the 1,308 CPSRMS incidents, 79 fall incidents showed the potential for serious injuries, and in many of these incidents, the child sustained a head injury. Of the 31,300 estimated NEISS incidents, 1,540 resulted in severe head injuries.

*D. Product Recalls*

Since January 1, 2010, there have been 10 recalls of high chairs involving eight firms. The recalled high chairs were responsible for a total of 72 injuries, including 44 injuries involving bumps and bruises, 11 lacerations requiring medical closure (stitches, tape, or glue), one scratched cornea, and one hairline fracture to the arm. These injuries were primarily due to falls from the high chair.

**IV. International Standards for High Chairs**

CPSC is aware of four international standards that apply to high chairs:

- ASTM F404–15;
- EN 14988: 2006, *Children’s High Chairs—Safety Requirements and Test Methods* (“European standard”);
- AS 4684–2009, *High Chairs—Safety Requirements* (“Australian standard”); and
- ISO 9221: 1992, *Furniture—Children’s High Chairs* (“ISO standard”).

CPSC staff reviewed the provisions in these four standards and believes that ASTM F404–15 best addresses the hazard patterns indicated in the incident data CPSC has received. In most areas, ASTM F404–15 includes more stringent requirements than the other three international standards. For example, to test forward stability, the European standard requires testing with an 11-pound load and 5.6 foot-pound force, while ASTM F404–15 requires testing with a 40-pound load and 14 foot-pound force, making it the more stringent standard.

In reviewing the provisions in which one of the other international standards includes more stringent requirements than ASTM F404–15, CPSC found that incident data do not indicate that the more stringent standard is necessary to reduce the risk of injury, and the requirements in ASTM F404–15 are sufficient. For example, the European standard has height requirements for the sides of high chairs, while ASTM F404–15 does not. However, incident data do not indicate that side height is a factor in fall hazard patterns. Similarly, the Australian standard requires castors or gliders to be in specific configurations, and the ISO standard only allows castors for convertible high chairs, while ASTM F404–15 has no requirements for castors. However, incident data do not indicate that castors are a common cause of injury.

Based on these comparisons, CPSC believes that ASTM F404–15 is, in general, a more stringent standard than the other three international standards and is better tailored to address the hazard patterns shown in the incident data.

## V. ASTM F404–15

### A. History of ASTM F404–15

ASTM first approved and published a standard for high chairs in 1975, as ASTM F404–75, *Standard Consumer Safety Specification for High Chairs*. ASTM has revised the voluntary standard many times since then, adding and modifying requirements. Some of the more substantial additions over the past 5 years include requirements for tray-release mechanisms, visibility and permanency of labels, restraint system

installation, and restraint anchor integrity. ASTM approved the current version, ASTM F404–15, on May 15, 2015.

### B. Description of ASTM F404–15

CPSC staff, together with stakeholders on the ASTM subcommittee task group for high chairs, developed modified and new requirements for ASTM F404–15 to address the hazards associated with high chairs. ASTM F404–15 includes the following key provisions: scope, terminology, calibration and standardization, general requirements, performance requirements, test methods, labeling and warnings, and instructional literature. The following provides an overview of these provisions; to view the complete standard, see the instructions in section X. of this preamble.

#### 1. Scope

This section states the scope and intent of the standard.

#### 2. Terminology

This section provides definitions of terms specific to the standard.

#### 3. Calibration and Standardization

This section provides general instructions for conducting tests.

#### 4. General Requirements

This section includes general requirements regarding various issues, such as components of a high chair, conversion kits, accessories, threaded fasteners, sharp edges and points, small parts, wood parts, latching or locking mechanisms, labels, openings, toy components, and lead in paint.

#### 5. Performance Requirements and Test Methods

These sections contain performance requirements and associated test methods for high chairs. The following summarizes key requirements in these sections.

a. Protective Components: These requirements provide for testing protective components such as caps and plugs.

b. Tray or Front Torso Support—Drop Test: Each removable tray and front torso support must be dropped from a specified height in multiple orientations. The purpose of this requirement is to test whether high chair components continue to function or exhibit mechanical hazards (e.g., sharp edges) after the drop test.

c. Tray or Front Torso Support—Pull Tests: The tray or front torso support must be pulled multiple times from multiple sides and directions with a

specified force. The purpose of this requirement is to test whether frontal support can withstand kicking or pulling.

d. Static Load: A high chair must support specified weights on the seat, tray, step, and footrest. The purpose of this requirement is to test whether the high chair seat and step can support more than the weight of a child and whether the tray can withstand overloading.

e. Stability: A high chair must not tip over when pulled forward, backward, or sideways by a specified force. The purpose of this requirement is to test the high chair’s resistance to falling over if an occupant leans forward, pushes off a nearby surface, or the high chair is otherwise pushed.

f. Exposed Coil Springs: Any exposed coil springs that reach a specified distance from each other during static load testing must be designed to prevent pinching or entrapment.

g. Scissoring, Shearing, and Pinching: Each accessible point at which components move (e.g., fastening points, pivots) must admit a probe with a specified diameter. The purpose of this requirement is to prevent scissoring, shearing, and pinching of an occupant.

h. Restraint System: The standard requires an active restraint system, such as a belt, to secure a child in the high chair. The restraint system must include waist and crotch restraints. In addition, the restraints must withstand upward and downward force tests as well as testing to pull on restraint system attachments. The purpose of these requirements is to ensure that the restraint system and its closing means remain anchored and functional under various forces.

i. Completely-Bounded Openings: This section requires high chairs with completely-bounded openings in front of the occupant to have a passive crotch restraint with specified maximum sizes for gaps and openings. The crotch restraint must be installed or tethered in place to prevent consumers from misinstalling or not installing it and tethers must withstand specified forces. The purpose of these provisions is to reduce the likelihood of injury or death from an occupant sliding through and being entrapped in an opening.

j. Structural Integrity: A high chair must withstand dynamic cycle testing, involving repeated drops of a weight on the seat, without any structural components breaking or the seat height or angle changing beyond a set limit. The purpose of this requirement is to test whether the high chair can

withstand the dynamic loads to which it will be subjected.

k. **Tray Latch Release Mechanisms:** The standard includes requirements for tray latches to prevent unintentional or accidental release. These requirements include specific types and placements for latch release mechanisms and testing to ensure they can withstand a specified force. The purpose of these requirements is to address incidents in which occupants fell from high chairs that had passive restraints integrated into the tray.

l. **Side Containment:** Any completely-bounded openings on the sides of the seat must meet specified maximum dimensions for gaps and openings. The purpose of this requirement is to reduce the likelihood of injury or death from an occupant sliding through and being entrapped in an opening.

m. **Protrusions:** Projections must meet certain dimensional requirements if they are located on the outside of high chair legs at a height a toddler is susceptible to falling into. The purpose of this requirement is to address the incidents in which children outside of high chairs sustained injuries from falling into tray storage hooks or other protrusions.

n. **Locking Mechanisms:** Locking mechanisms must be able to withstand a specified force.

o. **Permanency of Labels and Warnings:** This section specifies testing and criteria for determining the permanency of labels.

## 6. Labeling and Warnings

This section contains various requirements related to warnings and labels, including content, format, and prominence requirements.

## 7. Instructional Literature

This section requires that instructions be provided with high chairs and be easy to read and understand. The instructions must comply with content, format, and prominence requirements.

## VI. Assessment of ASTM F404–15

CPSC considered the fatalities, injuries, and non-injury incidents associated with high chairs that occurred between January 1, 2011 and December 31, 2014, and staff evaluated ASTM F404–15 to determine whether the voluntary standard addresses these hazards or whether more stringent standards would reduce the risk of injury associated with high chairs. CPSC believes that ASTM F404–15 effectively addresses the hazards indicated in the incident data, with the exception of two areas. CPSC believes that more stringent requirements than those in ASTM

F404–15 would further reduce the risk of injury associated with high chairs regarding rearward stability and warnings on labels and in instructional literature. Consequently, CPSC proposes additional requirements for those areas.

This section provides CPSC's assessments of how ASTM F404–15 addresses the hazard patterns in the incident data. In its analysis, CPSC identified broad categories into which the incidents fall. One category is components of high chairs, including issues with frames, seats, restraint systems, armrests, trays, toy accessories, wheels, footrests, and miscellaneous issues. Another category is general problems with high chairs, including design and stability issues. And the final category includes incidents that did not clearly fall within any of the above groupings—these are listed below as consumer observations and undetermined. This section discusses each of these hazard patterns, in descending order of frequency of incidents within each of the three categories (see Table 2, above). Section VIII. discusses the additional requirements that CPSC proposes for rearward stability and warnings.

### A. Frame

There were 650 CPSRMS incidents involving the frame of a high chair, resulting in a total of 20 injuries. Common incidents included cracked frames or height adjusters, loose screws, and buckling legs. More than 80 percent of frame-related incidents involved cracked components on two similar high chair models from one manufacturer and resulted in only a few minor injuries.

ASTM F404–15 contains two separate requirements intended to provide structural integrity to high chair frames—a static load test and a drop test. Several general requirements also address the hazards associated with frame failures, such as the requirements regarding the use of certain screws for key structural elements to provide for proper installation and durability over time. Since frame-related incidents are not an industry-wide problem, CPSC believes that the ASTM F404–15 requirements for structural integrity, load tests, and fasteners effectively address the safety hazards related to high chair frames.

### B. Seat

There were a total of 205 incidents involving the seat of a high chair, resulting in 41 injuries. Seat-related issues include cracked or peeling seat pads, broken seat reclining hardware, seat backs detaching, and loose screws.

Nearly 60 percent of seat issues involved a single manufacturer's seat pads cracking or peeling after multiple washings. Eighty-three percent of seat-related injuries involved cracked or peeling seat pads scratching occupants' legs.

ASTM F404–15 contains two requirements that address the integrity of structural components of a high chair, including the seat. These are the static load test and drop test. General requirements, such as those regarding sharp points and small parts, also address the risk of laceration or choking on pieces that detach from the seat. CPSC believes that ASTM F404–15 effectively addresses the hazards associated with high chair seats.

### C. Restraint System

There were 139 incidents involving the restraint system of a high chair, resulting in 12 injuries. These issues generally fall into two categories—restraint systems that failed and unused restraint systems.

Within the first category, incidents included buckles breaking or separating from straps, straps tearing or pulling out of anchor points, and other issues. To address these issues, ASTM F404–15 requires all high chairs to be shipped with two types of restraint systems—a pre-attached “active” crotch and waist belt restraint system and a “passive” crotch restraint—that have undergone testing to ensure they work as intended. ASTM F404–15 also requires the restraint anchors to withstand a pull test. CPSC believes that ASTM F404–15 effectively addresses the hazard pattern associated with restraint system failures.

As for the second category, unused restraint systems, CPSC believes that a more stringent standard for labels and instructional literature than ASTM F404–15 would further reduce the risk of injuries associated with this issue. CPSRMS and NEISS data indicate that, in many incidents, caregivers did not use the restraint system. CPSC believes more effective warnings would increase consumer use of restraint systems and reduce these incidents.

CPSC's review of CPSRMS data revealed that of the 1,308 incidents involving high chairs, there were numerous cases in which the caregiver did not use the high chair restraints, resulting in the child falling or nearly falling from the high chair. Although many incident reports have limited detail, CPSC noted that several incidents involved a child falling from a high chair when the tray disengaged, suggesting the tray was used as the sole restraint. Several reports also indicated that a caregiver's attention was

elsewhere when the incident occurred. And several other reports suggested that the restraint system was ineffective at restraining the child or was used improperly.

CPSC's review of NEISS data revealed a similar pattern. The vast majority of NEISS incidents involved falls, which suggests that restraints were unused or ineffective. Although NEISS data provide limited details, many reports state that the child was not restrained or that the restraint had just been removed when the incident occurred. In some cases, the incident happened when a caregiver turned away from the child, and some reports stated the child was strapped in before the fall, suggesting the restraint fit poorly or was not adjusted properly.

CPSC believes that the requirements in ASTM F404-15 do not adequately address the risk of injury associated with unused or improperly used restraint systems. ASTM F404-15 includes three types of requirements relevant to this hazard. First, the standard requires the passive crotch restraint to arrive attached or tethered to its manufacturer's recommended use position to reduce the chances that the restraint is not installed before use. Second, section 8 of ASTM F404-15 requires warnings about the risk of serious injury or death from falling or sliding out of a high chair, instructions to use the restraint system, and a warning never to leave a child unattended. Some of these warnings must be visible to a person standing near the high chair at any one position when a child is in the high chair, but not necessarily visible from all positions. Other warnings must be visible to a caregiver while placing a child in the high chair, but not necessarily visible when the child is in the high chair. Third, section 9 of ASTM F404-15 specifies that instructional literature provided with a high chair must include the same warning statements that are on the high chair; state that only children capable of sitting upright unassisted should use a high chair; advise consumers to use the restraint system; and inform consumers that the tray is not a restraint system.

CPSC believes that more stringent content, form, and placement requirements for warnings than ASTM F404-15's would further reduce the risk of injury associated with unused restraint systems. Section VIII. discusses CPSC's proposed labeling and instructional literature requirements in greater detail.

#### *D. Armrest*

Eighty-one high chair incidents involved armrests and resulted in two injuries. Many of the reports indicate armrests broke as users removed the tray. All but one of the armrest incidents involved a single high chair model.

ASTM F404-15 includes several performance tests that address this hazard. For example, the static load and pull tests for trays also evaluate the durability of armrests because trays are typically attached to armrests. CPSC believes that ASTM F404-15 effectively addresses the armrest hazard pattern. The incident reports indicate this is not an industry-wide problem; there were only a small number of minor injuries associated with armrests, and ASTM F404-15 includes tests for armrest durability.

#### *E. Tray*

A total of 75 high chair incidents involved trays and resulted in 33 injuries. Common tray incidents included pinching, and in addition, falls that occurred when trays unexpectedly detached or released too easily.

ASTM F404-15 contains several performance requirements that address tray incidents, including pull tests, a static load test, and specific tray-latching requirements. Provisions on tray latch accessibility and latch actuation that ASTM adopted in 2007 and 2010 have been effective at reducing tray-related incidents, as data show a decline in incidents for models manufactured after those revisions. General requirements, such as those for sharp edges and scissoring, shearing, and pinching, also address these hazards. CPSC believes that ASTM F404-15 effectively addresses the tray hazard pattern.

#### *F. Toy Accessories*

Toy accessories were involved in 70 high chair incidents, resulting in one injury. These reports indicate toy accessories cracked or broke.

ASTM F404-15 includes requirements for toy accessory durability, requiring manufacturers to attach toy accessories to the high chair for testing, including tray drop testing and load cycle testing. CPSC believes ASTM F404-15 effectively addresses the toy accessory hazard pattern. CPSC expects the toy durability requirements in ASTM F404-15, as well as the general requirement in ASTM F404-15 calling for compliance with ASTM's toy standard, ASTM F963, *Standard Consumer Safety Specification for Toy Safety*, to reduce hazards related to cracked or broken toy accessories.

#### *G. Wheels*

Wheels were involved in 21 high chair incidents, resulting in one injury. Common incidents involved wheels becoming loose, breaking, or not locking. All but two of these incident reports cited cracked or broken components of high chairs from one manufacturer and almost all of these were the same model. In the single incident that resulted in an injury, the wheel was only a minor contributing factor.

ASTM F404-15 evaluates wheel durability through a static load test and drop test. CPSC believes that ASTM F404-15 effectively addresses this hazard pattern, as wheel issues do not appear to be an industry-wide hazard pattern, do not contribute to a substantial number of injuries, and ASTM F404-15 contains provisions that evaluate wheel integrity.

#### *H. Footrests*

Fourteen high chair incidents involved footrests and resulted in no injuries. All of the incident reports cited footrests cracking on a single high chair model.

ASTM F404-15 includes a static load test to evaluate the durability of footrests. CPSC believes that ASTM F404-15 effectively addresses this hazard pattern, as this is not an industry-wide issue, and ASTM F404-15 includes requirements for footrest durability.

#### *I. Miscellaneous Issues*

High chair incident reports included various additional issues, such as paint with excessive lead content, cracked wood finish, loose screws, and assembly problems. Eight high chair incident reports cited these miscellaneous issues and resulted in one injury.

ASTM F404-15 contains several requirements that address these various issues, such as issues with screws on consumer-assembled structural components, sharp edges, small parts, exposed wood, and compliance with 16 CFR part 1303 (banning lead-containing paint). ASTM F404-15 also includes requirements for instructional literature, intended to provide clear assembly instructions. CPSC believes that ASTM F404-15 effectively addresses these issues.

#### *J. Design*

Design issues were involved in 22 high chair incidents, resulting in 13 injuries. Incident reports relating to the design of a high chair primarily cited designs that create entrapment hazards. These hazards commonly resulted in children's arms being entrapped

between the back of a high chair and the tray or children's legs catching in the gap between the bottom of the tray and the top of the passive crotch restraint. In the most severe cases, children slid into leg hole openings under the tray and hung by their necks.

To address these "submarining" cases, ASTM F404-15 contains several performance tests that specifically address openings, including a probe test for gaps and completely-bounded openings in front of occupants, around the passive crotch restraint, and between horizontal portions and the tray. The standard also includes a test for leg openings and openings around the sides of the high chair seat to ensure that occupants cannot slide through and become entrapped. ASTM F404-15 requires manufacturers to attach passive crotch restraints to the high chair to increase the likelihood that consumers will use restraints and reduce submarining incidents. ASTM F404-15's requirements on openings and scissoring, shearing, and pinching address less serious entrapment hazards. CPSC believes that ASTM F404-15 effectively addresses the design hazard pattern.

#### K. Stability

Stability issues played a role in 16 high chair incidents, resulting in 12 injuries. This hazard pattern includes forward tip-overs, side tip-overs, and rearward tip-overs. Tip-overs generally occur when a child leans out of the high chair or pushes off a nearby surface. In NEISS reports that included enough detail to identify the cause of the incident, the vast majority of the incidents were falls resulting from tip-overs, mostly rearward tip-overs. CPSC data also included reports of many injuries resulting from high chairs tipping over, also frequently rearward tip-overs.

ASTM F404-15 requires forward, sideways, and rearward tip-over testing. The standard also contains a stability requirement to simulate the load applied by a child climbing into the chair. CPSC believes that ASTM F404-15 effectively addresses forward and sideways tip-overs. However, based on the frequency of rearward tip-over incidents, CPSC believes that ASTM F404-15 does not adequately address rearward tip-over hazards and a more stringent standard is necessary. Section VIII. discusses CPSC's proposed rearward stability standard.

#### L. Consumer Observations

Three incident reports involved consumers' perceived safety hazards or complaints about high chairs, but none

of the incidents resulted in injuries. These reports did not provide enough information for CPSC to assess the adequacy of ASTM F404-15 regarding the reported concerns.

#### M. Undetermined

Four high chair incident reports did not provide sufficient information for CPSC to determine how the incidents, including the one reported death and two injuries, occurred. The lack of information available in these incident reports made it impossible for CPSC to assess the effectiveness of ASTM F404-15 in addressing these issues.

### VII. Restaurant-Style High Chairs

ASTM F404-15 applies to high chairs without distinguishing where consumers use them. However, many high chairs are designed to be used in commercial settings, primarily restaurants ("restaurant-style high chairs"). These high chairs generally include features that are particularly useful in commercial or restaurant settings and may not present the same hazards as high chairs used in the home. Based on CPSC's review of incident data and the potential economic impact of the requirements proposed in this NPR, it is possible that, due to the unique environmental factors in restaurant settings, high chairs used in these settings may present lesser hazards and warrant fewer requirements to reduce the risk of injury associated with high chairs. The following describes the factors that weigh in favor of and against distinguishing restaurant-style high chairs from other high chairs and possible options for distinguishing them.

Of the 1,296 CPSC incident reports, three explicitly state that the incidents occurred in restaurants while consumers used the establishments' high chairs. Restaurant-style high chairs have several distinct features. This style of chair is generally constructed from robust materials, such as wood or plastic and do not have trays. Therefore, restaurant-style high chairs can be pulled up to a table. In addition, restaurant-style high chairs are designed to be compact and stackable for easy storage and have little space available for labels. Restaurant-style high chairs are also generally designed to be lower to the ground and narrower than high chairs intended for home use. Additionally, restaurant-style high chairs are designed not only to accommodate a wide range of ages, from infants to toddlers, but also accommodate bulky outerwear and shoes. These design attributes are desirable in a restaurant setting to adapt

to the environment and be versatile and compact. However, these features also make it difficult for these high chairs to comply with the requirements in ASTM F404-15 and the additional requirements proposed in this NPR.

There are several requirements that restaurant-style high chairs frequently do not follow. Contrary to ASTM F404-15, wedge blocks can generally pass through the leg openings of restaurant-style high chairs. The large side and back openings also do not meet ASTM F404-15. The belt used as a passive restraint often fits loosely over the top rail of the high chair and does not meet the passive restraint requirements of ASTM F404-15. The lower and narrower stance of these high chairs also may impact the chairs' compliance with the stability requirements in ASTM F404-15. Moreover, there is little space on these high chairs to accommodate the label requirements in ASTM F404-15 or the additional requirements CPSC proposes.

There are several reasons it may be appropriate to apply different requirements to restaurant-style high chairs. First, the environment in which restaurant-style high chairs are used may not present the same hazards that are common in the home. In a restaurant environment, caregivers sit next to the child seated in the high chair, are unlikely to leave a child unattended in the high chair, and are not distracted by the tasks that may divert the caregiver's attention in a home environment. For these reasons, a caregiver would likely be able to prevent an incident from occurring, or correct any issue quickly, before serious injury or death could occur. None of the three incidents involving restaurant-style high chairs reported to CPSC involved children who were unattended and entrapped in the openings of the high chair. Because caregivers are likely to be nearby and attentive, it is likely to be less necessary for warnings regarding attending the child to be visible when the child is in the high chair. Second, modifying restaurant-style high chairs to comply with ASTM F404-15 would likely reduce their utility because these high chairs would no longer accommodate larger children or bulky clothes, and would be less compact and not stackable. Finally, given the possible lesser safety issues, the proposed requirements in this NPR impose proportionately high costs on restaurant-style high chair suppliers because these products require more changes to come into compliance.

There are also several reasons to apply the same requirements to restaurant-style high chairs and other

high chairs. First, restaurant-style high chairs are readily available to consumers and are also used in homes. Two of the firms that market their products to consumers produce high chairs identical to the wooden high chairs used in restaurants. This negates the environmental factors that support distinguishing high chairs used in restaurants. Second, there is minimal incident data to indicate whether high chairs actually pose lesser safety risks in restaurant settings. It is also possible that, although caregivers in restaurants are near the child, caregivers may be less likely to attend to the child or use the restraint system because caregivers assume they are near enough to the child to prevent an incident. As the incident data indicate, this may not be correct, as incidents can happen quickly. Finally, because high chairs are readily available to consumers, it may be difficult, practically, to apply different requirements to these high chairs.

Some options for treating restaurant style-high chairs differently than other high chairs include excluding restaurant-style high chairs from the proposed standard or modifying individual requirements, such as label placement and bounded-openings, to reflect the features and lesser safety issues associated with restaurant-style high chairs.

CPSC requests comments on the following factors: whether it is appropriate to distinguish these high chairs, which requirements should differ, and how CPSC could apply those distinctions.

## VIII. Description of Proposed Changes to ASTM Standard

The proposed rule would create part 1231, titled, *Safety Standard for High Chairs*. As explained above, the Commission believes that ASTM F404–15 effectively addresses the safety hazards associated with high chairs, with the exception of rearward stability and warnings in labels and instructional literature. For this reason, the Commission proposes to incorporate by reference ASTM F404–15, with modified requirements for rearward stability and warnings. This section discusses the proposed changes to ASTM F404–15.

### A. Rearward Stability

Based on the incident data discussed above, CPSC believes that a more stringent standard than ASTM F404–15 for rearward stability would further reduce the risk of injury. CPSC staff has tested the high chair models involved in incidents and found that the tested

models passed the requirements of ASTM F404–15. To develop a performance test to measure and improve the rearward stability of high chairs, CPSC worked with an ASTM task group to develop an alternative rearward stability test, based on CPSC staff's and manufacturers' testing. Although this test is not included in ASTM F404–15, ASTM may adopt the test in future revisions. CPSC proposes to adopt this test, in lieu of the rearward stability test in ASTM F404–15.

The proposed standard is based on a rearward stability index ("SI") rating that evaluates the factors that contribute to rearward tip-overs and sets a minimum SI score for high chairs. The task group developed the SI based on a review of various stability requirements, the incident data, and testing numerous high chair models, including those involved in rearward tip-over incidents and those not reported to be involved in such incidents. The SI measures the elements associated with high chair occupants pushing back from a surface. The SI rates high chairs based on two characteristics associated with rearward tip-overs—the force ("F") required to tip the chair over in the rearward direction and the distance ("D") that a reference point on the seat travels as the chair tilts from the manufacturer's recommended use position to the point of instability just before tipping over. A chair design will score well if it requires a large push-off force and/or a long distance to reach its tipping point. CPSC's and manufacturers' tests determined that the tip force is a more critical factor in identifying unstable chairs. As such, the SI weights F twice as heavily as D:  $SI = 2F + D$ .

The test method CPSC developed through this testing and proposes in this NPR includes the following elements:

- Attach a force gauge to the center line of the back of the seat, 7.25" above the seating surface and preload it with 3 pounds of force (to eliminate any slack in fabric or loose seats);
  - Establish an initial reference point along the plane of the force gauge;
  - Gradually apply a rearward, horizontal force until the point at which the chair becomes unstable and begins to tip over backward;
  - Record the maximum force applied during the tip test, along with the total distance the reference point moved from its predetermined position; and
  - Calculate the SI by multiplying the force by a factor of two and adding the distance. Based on the product testing conducted, CPSC proposes requiring high chairs to have an SI of 50 or more.
- CPSC also proposes to include requirements for the test surface and

positioning of the high chair for rearward stability testing. These requirements are based on CPSC staff's testing initiative and aim to reduce variation in test results. First, CPSC proposes to require the high chair seat back, tray, seat, and wheels to be in specific positions for rearward stability testing. This will decrease variability in test methods and results, and based on testing, CPSC believes that these positions are the most effective for assessing high chair stability.

Second, CPSC proposes to require a specific test surface, including 60-grit sandpaper to prevent sliding and maximum parameters for the stop block placed behind a high chair with wheels to instigate tipping. Without these requirements, test results vary because test surfaces differ and the height of a stop block affects the amount of force necessary to tip over a high chair.

The proposed rearward stability requirement and test procedure are effective at identifying high chairs that have been involved in rearward tip-over incidents. As such, CPSC believes this more stringent standard would further reduce the risk of injury associated with rearward high chair tip-overs, and proposes requiring this modification to ASTM F404–15.

### B. Warnings in Labels

Based on incident data discussed above and research on effective warnings, CPSC believes that the on-product warning requirements in ASTM F404–15 do not adequately address the safety risks associated with high chairs; therefore, CPSC proposes more stringent requirements that would further reduce the risk of injury associated with falls from high chairs. Specifically, CPSC proposes additional content, form, and placement provisions for on-product warnings labels. Tab E of CPSC staff's briefing package for this proposed rule includes additional details about these proposed requirements and the rationale behind them. The briefing package is available at: <http://www.cpsc.gov/Newsroom/FOIA/Commission-Briefing-Packages/>.

#### 1. Content

CPSC proposes to require high chairs to bear labels that address the following statements:

Children have suffered skull fractures after falling from high chairs. Falls can happen quickly if child is not restrained properly.

- Always use restraints, and adjust to fit snugly. Tray is not designed to hold child in chair.
- Stay near and watch your child during use.

CPSC believes this language would be more effective than ASTM F404–15's language at reducing the risk of injury associated with falls from high chairs. CPSC developed the proposed warning language from information developed through research on the content of warnings. The proposed rule refers to ANSI Z535.4, *Product Safety Signs and Labels* ("ANSI Z535.4"), for guidance on warning label designs. ANSI Z535.4 is the primary U.S. voluntary consensus standard for product safety signs and labels. The standard is available at: <http://www.ansi.org/>. ANSI Z535.4 addresses the design, application, use, and placement of on-product warning labels. CPSC's Division of Human Factors regularly uses ANSI Z535.4.

As the staff briefing package discusses, literature and guidelines about warnings consistently recommend that on-product warnings include:

- A description of the hazard;
- information about the consequences of exposure to the hazard; and
- instructions about appropriate hazard-avoidance behaviors.

The warning statements in ASTM F404–15 lack important details regarding the hazard and its consequences, providing only a vague description of the types of injuries that may occur. As staff's briefing package for this proposed rule indicates, providing more detailed and vivid information in a warning increases its effectiveness. Accordingly, CPSC developed the proposed language, describing the specific hazard, consequent injuries, and precise actions that can help reduce the likelihood of the hazard.

As Tab E of CPSC staff's briefing package for this proposed rule discusses, incident data and other research reveals the following:

- Falls can happen quickly;
- falls occur when caregivers are not close by or watching a child;
- falls occur when caregivers do not use the restraint system;
- falls occur when caregivers do not use the restraint system properly; and
- receiving information about a hazard, its consequences, and mitigating actions, motivates appropriate behavior.

As discussed in further detail in Tab E of CPSC staff's briefing package, CPSC does not believe that ASTM F404–15 includes adequately detailed requirements to address many of these factors. To increase the effectiveness of warnings and further reduce the risk of injury, CPSC proposes the following for high chair warnings:

- A statement describing the speed with which incidents can occur;

- a detailed description of what "attending" means, including staying near and watching a child;

- an instruction to use the restraint system and a statement that the tray is not part of the restraint system;
- an instruction to adjust the restraints to fit the child snugly; and
- a warning statement regarding the hazard, consequences, and appropriate actions to appear together on a label.

Similarly to ASTM F404–15, CPSC proposes that for high chairs that have a seating component that is also used as a seating component for a stroller, the content of the labels must comply with ASTM F833, *Standard Consumer Safety Performance Specification for Carriages and Strollers* ("ASTM F833"). However, although ASTM F404–15 only requires compliance with section 8.2.2.2 of ASTM F833, CPSC also proposes to require the additional warning provided in section 8.2.2.1. CPSC incorporated the most recent revision of this standard (ASTM F833–13b) into 16 CFR part 1227 as the safety standard for carriages and strollers, with some modifications, effective September 10, 2015. 79 FR 13,208 (Mar. 10, 2014).

## 2. Form

Research indicates that the form of a warning can affect the extent to which consumers notice and read the warning. The form of a warning can also communicate the seriousness of a hazard, which can affect compliance with recommended behavior. CPSC considered research on effective forms for warnings, including the requirements in ANSI Z535.4, in developing the proposed form requirements. ASTM F404–15 does not include several of the features that have been found to be effective, including colors, contrast, typeface, and layout.

As discussed in Tab E of CPSC staff's briefing package for this proposed rule, research indicates the following points about the format of warnings:

- Certain colors, particularly red, orange, and yellow, attract attention and help convey the presence of a hazard;
- the degree of contrast contributes to readability;
- certain typeface styles, such as sentence capitalization (*i.e.*, mixed upper and lowercase) and boldface, are easier to read and more effective at highlighting information than extensive capitalization;
- left-justified text is easier to read than fully-justified text;
- condensed or narrow typeface is less effective at conveying information; and
- lists and outline formats provide for better absorption and retention of

information than continuous paragraph text.

ASTM F404–15 does not include specific requirements for many of these factors. To increase the effectiveness of warnings and further reduce the risk of injury, based on this research, CPSC proposes the following for high chair warnings:

- Red, orange, or yellow on-product warnings;
- highly contrasting colors, such as black and white;
- sentence capitalization, with key phrases emphasized in boldface;
- left-justified text;
- non-condensed typeface; and
- outline format.

## 3. Placement

As discussed above, the warning placement and visibility requirements in ASTM F404–15 permit different portions of warning information to appear on separate labels. CPSC believes that to be most effective, all of the warning information should appear together because the hazard description and potential injuries help motivate caregivers to take the recommended actions. Similarly, CPSC believes that it is important for caregivers to be able to see the warnings when putting a child into a high chair and when the child is in it. This will remind users to use the restraint system when putting the child into the high chair and to stay near and watch the child once the high chair is in use. ASTM F404–15 only requires certain warning information to be visible when a caretaker is placing a child in the high chair, not once the chair is occupied; and the standard requires other warning information to be visible when the child is in the chair. Based on the incident data, CPSC believes it would more effectively reduce the risk of injury associated with falls from high chairs if users could see the warning after putting a child in the high chair and before leaving the child unattended. As such, CPSC proposes requiring warning labels to be visible when placing the occupant in the high chair and once the child is in the high chair.

## 4. Additional Guidance

CPSC also proposes to include a note in the regulatory text referencing ANSI Z535.4 for optional additional guidance. CPSC would not require compliance with ANSI Z535.4, but the standard may offer regulated entities additional useful information for developing effective labels.

### C. Warnings in Instructional Literature

For reasons similar to using warnings in on-product labels, CPSC proposes more stringent requirements for warnings in instructional literature than ASTM F404–15 provides. CPSC believes that more stringent requirements will further reduce the risk of injury associated with high chairs by providing more effective warnings regarding the hazard, potential injuries, and recommended behavior. This includes requirements about the content and form of warnings in instructional literature. The discussion below provides the rationale for these more-stringent requirements, and the requirements are discussed in additional detail in Tab E of CPSC staff's briefing package for this proposed rule.

#### 1. Content

Section 9.2 of ASTM F404–15 requires that instructional literature contain the same warnings as the warnings required on the high chair. CPSC believes that this requirement is appropriate. However, because CPSC proposes to require different on-product warning label content than ASTM F404–15, the more-stringent warning requirements also would apply to instructional literature. The Commission agrees with the additional content requirement listed in section 9.2.1 of ASTM F404–15. Therefore, CPSC does not propose to modify that requirement.

#### 2. Form

Unlike on-product warning labels, ASTM F404–15 does not specify the form in which warning statements in instructional literature must appear. Similarly to on-product warning labels, research and guidance indicate that specific forms are more effective at conveying information. The proposed rule refers to ANSI Z535.6, *Product Safety Information in Product Manuals, Instructions, and Other Collateral Materials* (“ANSI Z535.6”) for guidance on the design and location of product safety messages in instructional literature. The standard is available at: <http://www.ansi.org/>.

CPSC proposes to require the same form requirements for warnings in instructional literature as the requirements proposed for on-product warning labels, with one exception. CPSC believes that these form requirements will further reduce the risk of injury associated with high chairs for the same reasons discussed for on-product warning labels. However, CPSC does not propose to require the use of specific colors (*i.e.*, red, orange,

yellow) for warnings in instructional literature unless a manufacturer opts to use color, in which case the same color requirements as on-product labels would apply.

#### 3. Additional Guidance

Similar to ANSI Z535.4, CPSC also proposes to include a note in the regulatory text referencing ANSI Z535.6 for optional additional guidance. CPSC would not require compliance with ANSI Z535.6, but the standard may offer regulated entities additional useful information for developing effective warnings in instructional literature.

### IX. Amendment to 16 CFR Part 1112 To Include NOR for High Chair Standard

Section 14 of the CPSA establishes requirements for product testing and certification. Manufacturers of products that are subject to a consumer product safety rule under the CPSA or another rule the Commission enforces must certify, based on product testing, that their product complies with all such rules. 15 U.S.C. 2063(a)(1). Additionally, manufacturers of children's products that are subject to a children's product safety rule must have these products tested by a third party conformity assessment body that CPSC has accredited, and manufacturers must certify that their products comply with all applicable children's product safety rules. *Id.* at 2063(a)(2). The Commission must publish an NOR for the accreditation of third party conformity assessment bodies to assess conformity with a children's product safety rule. *Id.* at 2063(a)(3). Because the proposed rule is a children's product safety rule, if the Commission issues 16 CFR part 1231, *Safety Standard for High Chairs*, as a final rule, the CPSC must also issue an NOR.

The Commission published a final rule, codified at 16 CFR part 1112, titled, *Requirements Pertaining to Third Party Conformity Assessment Bodies*, which established requirements for accreditation of third party conformity assessment bodies to test for conformity with children's product safety rules in accordance with the CPSA. 78 FR 15836 (Mar. 12, 2013). Part 1112 also codifies all of the NORs the Commission previously issued.

NORs for new children's product safety rules, such as the high chair standard, require the Commission to amend part 1112. To accomplish this, as part of this NPR, the Commission proposes to amend part 1112 to add high chairs to the list of children's product safety rules for which CPSC has issued an NOR.

Test laboratories applying for acceptance as a CPSC-accepted third party conformity assessment body to test for compliance with the proposed standard for high chairs would be required to meet the third party conformity assessment body accreditation requirements in part 1112. When a laboratory meets the requirements of a CPSC-accepted third party conformity assessment body, the laboratory can apply to CPSC to have 16 CFR part 1231, *Safety Standard for High Chairs*, included in the laboratory's scope of accreditation of CPSC safety rules listed for the laboratory on the CPSC Web site at: [www.cpsc.gov/labsearch](http://www.cpsc.gov/labsearch).

### X. Incorporation by Reference

Section 1231.2(a) of the proposed rule incorporates by reference ASTM F404–15. The Office of the Federal Register (“OFR”) has regulations concerning incorporation by reference. 1 CFR part 51. Under these regulations, in the preamble of the NPR, an agency must summarize the incorporated material and discuss the ways the material is reasonably available to interested parties or how the agency worked to make the materials reasonably available. 1 CFR 51.5(a).

In accordance with the OFR's requirements, section V.B. of this preamble summarizes the provisions of ASTM F404–15 that the Commission proposes to incorporate by reference. ASTM F404–15 is copyrighted. By permission of ASTM, interested parties may view the standard as a read-only document during the comment period of this NPR at: <http://www.astm.org/cpsc.htm>. Interested parties may also purchase a copy of ASTM F404–15 from ASTM International, 100 Bar Harbor Drive, P.O. Box 0700, West Conshohocken, PA 19428; <http://www.astm.org/cpsc.htm>. You may also inspect a copy at CPSC's Office of the Secretary, U.S. Consumer Product Safety Commission, Room 820, 4330 East West Highway, Bethesda, MD 20814, telephone 301–504–7923.

### XI. Effective Date

The Administrative Procedure Act (5 U.S.C. 551–559) generally requires that the effective date of a rule be at least 30 days after publication of the final rule. 5 U.S.C. 553(d). To allow time for high chairs to come into compliance with the standard, the Commission proposes that the standard become effective 6 months after publication of the final rule in the **Federal Register**. Without evidence to the contrary, CPSC generally considers 6 months to be sufficient time for suppliers to come into compliance with

a new standard, and 6 months is typical for other CPSIA section 104 rules. Six months is also the period that the Juvenile Products Manufacturers Association (“JPMA”) typically allows for products in the JPMA certification program to transition to a new standard once that standard is published. We also propose that the amendment to part 1112 become effective 6 months after publication of the final rule. We ask for comments on this proposed effective date.

**XII. Regulatory Flexibility Act**

*A. Introduction*

The Regulatory Flexibility Act (“RFA”; 5 U.S.C. 601–612) requires agencies to consider the impact of proposed rules on small entities, including small businesses. Section 603 of the RFA requires the Commission to prepare an initial regulatory flexibility analysis (“IRFA”) and make it available to the public for comment when the NPR is published. The IRFA must describe the impact of the proposed rule on small entities and identify significant alternatives that accomplish the statutory objectives and minimize any significant economic impact of the proposed rule on small entities.

Specifically, the IRFA must discuss:

- The reasons the agency is considering the action;
- the objectives and legal basis of the proposed rule;
- the small entities that would be subject to the proposed rule and, when possible, an estimate of the number of small entities that would be impacted;
- the projected reporting, recordkeeping, and other compliance requirements of the proposed rule, including the classes of small entities subject to it and the professional skills necessary to prepare the reports or records; and
- the relevant federal rules that may duplicate, overlap, or conflict with the proposed rule. 5 U.S.C. 603.

This section summarizes the IRFA for this proposed rule. Based on CPSC’s analysis, staff cannot rule out a significant economic impact for 20 of the 38 firms (53 percent) operating in the U.S. market for high chairs.

*B. Market Description*

CPSC identified 62 firms that supply high chairs to the U.S. market. The majority of these firms are domestic (including 27 manufacturers, 19 importers, and 5 wholesalers). The remaining 11 firms are foreign (including 9 manufacturers, 1 importer, and 1 retailer). Forty-eight of these firms market their products to consumers,

while 14 firms market their products for use in commercial settings, such as restaurants, hotels, and day care centers. However, consumers are able to purchase high chairs that are generally designed and marketed for use in commercial settings; two of the firms that market their products to consumers also produce high chairs identical to the wooden high chairs used in restaurants.

*C. Reason for Agency Action, Objectives, and Legal Basis for Proposed Rule*

Section 104 of the CPSIA requires the CPSC to promulgate a mandatory standard for high chairs that is substantially the same as the voluntary standard or more stringent than the voluntary standard if the Commission determines that more stringent requirements would further reduce the risk of injury associated with the product.

*D. Description of the Proposed Rule*

CPSC proposes to adopt ASTM F404–15 with modifications to the rearward stability test and requirements for warnings on labels and instructional literature. Section V. of this preamble discusses key provisions of ASTM F404–15.

CPSC believes that the high chairs of 37 firms comply with ASTM F404. This is because JPMA has certified the high chairs supplied by 12 firms, and the remaining 25 firms state that they comply with the voluntary standard. As such, these firms will not incur additional costs to comply with the provisions of ASTM F404–15, which CPSC proposes to adopt.

In addition to incorporating ASTM F404–15 by reference, CPSC proposes to adopt modified requirements for rearward stability and warnings in labels and instructional literature because CPSC believes that more stringent standards in these areas would further reduce the risk of injury. Section VIII. of this preamble discusses these proposed provisions.

Preliminary testing by CPSC staff and other members of the ASTM task group indicates that most high chairs would pass the proposed rearward stability test, and therefore, would not require any modifications to meet the proposed standard. Through testing high chairs and other market research, staff identified only three high chairs that might not pass the modified rearward stability test, based on their design. However, CPSC expects that the cost of modifying the design to increase rearward stability would be low, and that this could likely be accomplished by adding flat supports to the bottom of each back leg.

The Commission is also proposing more stringent requirements for warnings in labels and instructional literature. All firms would be affected by the proposed requirements for warnings in labels and instructional literature. Each firm would need to modify the text and formatting of the warnings for both the product and the instructional literature. Firms would need to move warning labels to the specified location, ensuring that the warnings are visible when the child is placed in the high chair and when the child is in the high chair. If the high chair can be used with and without padding, this would require placing the warning on both the high chair and the padding. Section XII.F. of this preamble discusses staff’s assessment of the impact of these proposed requirements on small entities.

*E. Other Relevant Federal Rules*

CPSC staff has not identified any federal or state rules that duplicate, overlap or conflict with the proposed rule.

*F. Impact of the Proposed Rule on Small Businesses*

CPSC is aware of approximately 62 firms currently marketing high chairs in the United States, 51 of which are domestic firms. Under U.S. Small Business Administration (“SBA”) guidelines, a high chair manufacturer is “small” if it has 500 or fewer employees, and importers and wholesalers are small if they have 100 or fewer employees. CPSC limited its analysis to domestic firms because SBA guidelines and definitions pertain to U.S. entities. Based on these guidelines and available information about the firms, staff has identified 38 of the 51 domestic suppliers as small (21 manufacturers, 13 importers, and 4 wholesalers). There may be additional small domestic high chair suppliers that CPSC is not aware of who are operating in the U.S. market. Table 3 lists the number of firms by category:

**TABLE 3—FIRMS THAT MARKET HIGH CHAIRS IN THE U.S.**

Category	Number of firms
Domestic .....	51
Small .....	38
Manufacturers .....	21
Compliant with ASTM F404 .....	12
Not Compliant with ASTM F404 .....	9
Importers and Wholesalers .....	17

TABLE 3—FIRMS THAT MARKET HIGH CHAIRS IN THE U.S.—Continued

Category	Number of firms
Compliant with ASTM F404 .....	9
Not Compliant with ASTM F404 .....	8
Large .....	13
Foreign .....	11
Total .....	62

#### 1. Small Manufacturers With Compliant High Chairs

Of the 21 small manufacturers, 12 produce high chairs that comply with ASTM F404–14. In general, CPSC expects small manufacturers that already comply with the voluntary standard will continue to comply with the standard as the standard evolves because they follow, and in three cases, actively participate in ASTM’s standard-development process. As such, compliance with the voluntary standard is part of these firms’ established business practice. Because ASTM approved ASTM F404–15 on May 15, 2015, these firms would likely be in compliance with the standard before the proposed rule would take effect.

For this reason, the economic impact of the proposed rule should be small for 10 of the 12 small domestic manufacturers. These 10 firms include one firm that may need to modify its high chair to meet the proposed rearward stability test; as discussed above, the cost associated with this modification is likely small.

However, the proposed warning label requirements may create a significant economic impact for two small manufacturers. Both firms produce high chairs with compact designs, with one serving the commercial restaurant market. Redesigning the seat back would provide additional space for warning labels, but may reduce the chairs’ compactness, which may be an important feature for marketability. For one firm, high chairs represent a small part of its product line, but it is unclear whether the firm could stop producing high chairs because CPSC was unable to obtain sales revenue information. For the second firm, high chairs represent an integral part of its commercial product line, so discontinuing that product line could create a significant economic burden. CPSC requests input on consumer preferences for compact high chairs, how compact high chair manufacturers would respond to the proposed warning label requirements,

and the costs of developing a compliant product.

#### 2. Small Manufacturers with NonCompliant High Chairs

Nine small manufacturers produce high chairs that do not comply with the voluntary standard, five who market their products for use in commercial settings, primarily in restaurants. CPSC believes it is possible that there would be a significant economic impact on some of these manufacturers. The five producers of restaurant-style high chairs would need to make several changes to meet the base requirements of ASTM F404–15. As discussed previously, different circumstances and needs exist for restaurant-style high chairs. Complying with the proposed rule may undermine some of the characteristics that make certain high chair features desirable in restaurant settings. For example, leg holes tend to be larger for restaurant-style high chairs to accommodate children clothed in outerwear and children of varied ages and sizes. The proposed standard would preclude some features.

Manufacturers of restaurant-style high chairs may also need to make changes to meet the proposed warning label requirements. For example, two firms manufacture plastic high chairs that may need to be redesigned to comply with the proposed warning label requirements.

Four firms that do not currently comply with the ASTM standard produce high chairs for home use. One of these four firms likely would need to make significant changes to its product to meet the proposed warning label requirements, given the compact design of its product. The three remaining firms appear to have sufficient room on their high chairs to accommodate the proposed warning labels without redesign, and any modifications to the high chairs would be due to the requirements of ASTM F404–15. However, CPSC staff could not determine the extent or cost of the changes that may be necessary, so we cannot rule out a significant economic impact.

CPSC requests comments on the differences between restaurant-style high chairs and high chairs produced for home use, as well as the desirability of particular features in these respective environments. CPSC also requests information about the changes that would be necessary to meet the proposed requirement, including whether redesign or retrofitting would be necessary and whether there would be any associated costs.

#### 3. Third Party Testing Costs for Small Manufacturers

Under section 14 of the CPSA, if CPSC adopts the proposed high chair requirements, all manufacturers will be subject to the third party testing and certification requirements under 16 CFR part 1107. Third party testing would include any physical and mechanical test requirements specified in a final high chair rule. Manufacturers and importers should already be conducting required lead testing for high chairs. Third party testing costs would be in addition to the direct costs of meeting the high chair standard.

More than half of small high chair manufacturers (11 out of 21) are already testing their products to verify compliance with the ASTM standard, although not necessarily by a third party laboratory. For these manufacturers, the impact on testing costs would be limited to the difference between the cost of third party tests and the cost of current testing regimes. The suppliers that CPSC staff contacted estimate that obtaining third party testing for high chairs would cost about \$600 to \$900 per model sample. For manufacturers that are already testing, the incremental costs will be lower than that.

Based on CPSC staff’s examination of firm revenues from recent Dun & Bradstreet or ReferenceUSAGov reports, the impact of third party testing, alone is unlikely to be economically significant for small manufacturers of noncompliant high chairs. Even without knowing how many samples would be needed to meet the “high degree of assurance” criterion in part 1107, more than 12 units per model would be required before testing costs exceed 1 percent of gross revenue for the small manufacturer with the lowest gross revenue. CPSC could not obtain revenue information for one small manufacturer, and therefore, could not evaluate the impact on that firm. CPSC requests comments on testing costs and incremental costs of third party testing (*i.e.*, how much does moving from a voluntary to a mandatory third party testing regime add to testing costs, in total, and on a per-test basis). In particular, CPSC requests comments on the preliminary determination that third party testing is unlikely to lead to significant economic impacts for small high chair manufacturers. In addition, CPSC would like comments about the number of high chair units that typically need to be tested to provide a “high degree of assurance.”

#### 4. Small Importers and Wholesalers With Compliant High Chairs

CPSC considered the economic impact to importers and wholesalers together, because both rely on outside firms to supply the products they distribute to the U.S. market. Importers distribute products made by foreign firms and are often closely related to the firms producing their products. CPSC was unable to determine the source of wholesalers' high chairs, but the sources are likely from other suppliers that may be foreign or domestic.

In the absence of a mandatory regulation, the nine firms (seven small importers and two small wholesalers) currently in compliance with the voluntary standard likely would remain in compliance with new versions. However, the high chairs these firms supply would require modifications to meet the proposed requirements. There are two firms that may require modifications to meet the rearward stability requirement (one importer and one wholesaler) but, as discussed above, these costs are likely to be low. The cost of modifying the wording and format of the warnings should be small, as well, given that such changes typically add only a few cents per unit to production costs.

The proposed placement requirements for warnings, however, could be more costly, possibly requiring firms to retrofit or redesign their high chairs. Four of the nine firms likely would have to modify the design of their high chairs to meet the proposed warnings label visibility requirement. The high chairs of two firms have compact designs, making the display of warning labels difficult. The remaining two firms provide information in a number of languages that would exceed the space available on their high chairs. Finding an alternative supply source would not be a viable alternative for three of the four firms, due to close relationships with their suppliers; however, all three firms supply a sufficient number of other products that could probably allow these firms to eliminate high chairs from their product line entirely. The fourth firm is a commercial supplier, and high chairs are an integral part of this firm's product line; therefore, exiting the high chair market would likely cause this firm to go out of business. CPSC requests comments on how importers would respond to the proposed rule and what are the costs of developing a compliant product.

#### 5. Small Importers and Wholesalers With Noncompliant High Chairs

There is insufficient information to rule out a significant impact for any of the eight importers and wholesalers of noncompliant high chairs. Whether there would be a significant economic impact would depend upon the extent of the changes required for these firms to come into compliance and the response of their suppliers. Their suppliers may pass on to the importers and wholesalers any increase in production costs that result from the proposed changes.

Six of the eight importers and wholesalers with noncompliant high chairs do not appear to have direct ties to their product suppliers. Therefore, these firms may choose to switch to alternative suppliers or manufacture other products, rather than bear the costs of complying with the proposed standard. It is unclear whether the costs of complying with the proposed requirements would be significant for these firms. Three firms supply restaurant-style high chairs, including one plastic high chair. As such, although the three firms may find compliant high chairs from alternative supply sources, these firms would share the same concerns as restaurant-style high chair manufacturers regarding the desirability of their product to their customers. Two of the six firms supply high chairs to the consumer market that are identical to several supplied to the commercial market. Although the costs of complying with the proposed standard could be significant for these two firms, high chairs make up only a small part of their product lines. Therefore, the two firms may eliminate high chairs from their product lines or select compliant high chairs from another supplier. However, CPSC was unable to obtain sales revenue for high chairs and could not determine whether exiting the high chair market would generate significant economic impacts.

The remaining two firms are directly tied to their foreign suppliers. Therefore, finding an alternative supply source would not be a viable alternative. However, these foreign suppliers may wish to comply with the proposed requirements to continue to market their products in the United States. Although it is possible that these firms could stop selling high chairs, it is unlikely for two of these firms because high chairs represent one of only a few products in their lines. Again, CPSC could not determine whether exiting the high chair market would generate significant economic impacts, given the lack of sales revenue for high chairs.

#### 6. Third Party Testing Costs for Small Importers and Wholesalers

As with manufacturers, all importers and wholesalers would be subject to third party testing and certification requirements, if CPSC adopts a final high chair standard. Consequently, importers and wholesalers would be subject to costs similar to manufacturers' costs if the foreign suppliers of importers and wholesalers do not obtain third party testing. Just over half of high chair importers and wholesalers (9 out of 17) already test their products to verify compliance with the ASTM standard. Any additional costs associated with a final high chair rule thus would be limited to the incremental costs of third party testing over the current testing regime.

There may be significant costs for two or three firms that do not comply with the ASTM standard to obtain third party certification. Specifically, for two firms, the cost of testing as few as three units per model could exceed 1 percent of their gross revenue. A third firm would need to test about six units per model before testing costs would exceed 1 percent of its gross revenue. CPSC was unable to obtain revenue data for one small, noncompliant importer, and therefore, could not examine the size of the impact on that firm.

#### 7. Summary of Impacts

CPSC staff is aware of 38 small firms that currently market high chairs in the United States, of which 21 are domestic manufacturers and 17 are domestic importers or wholesalers. Of the 21 small manufacturers, 10 are unlikely to experience significant economic impacts as a result of the proposed rule. However, CPSC cannot rule out a significant economic impact for the remaining 11 manufacturers. For eight of the small importers and wholesalers, it is unlikely the proposed rule would have a significant economic impact, based on a review of firm revenues and the options available to each firm. However, it is possible that the proposed rule would have a significant economic impact on the remaining nine small importers and wholesalers. Therefore, in total, based on current information, CPSC cannot rule out a significant economic impact for 20 of the 38 firms (53 percent) operating in the U.S. high chair market.

#### 8. Impacts of Test Laboratory Accreditation Requirements on Small Laboratories

In accordance with section 14 of the CPSA, all children's products that are subject to a children's product safety

rule must be tested by a third party conformity assessment body that has been accredited by CPSC. These third party conformity assessment bodies test products for compliance with applicable children's product safety rules. Testing laboratories that want to conduct this testing must meet the NOR for third party conformity testing. CPSC has codified NORs in 16 CFR part 1112. CPSC proposes to amend 16 CFR part 1112 to establish an NOR for testing laboratories to test for compliance with the proposed high chair standard. This section assesses the impact of this proposed amendment on small laboratories.

CPSC conducted a Final Regulatory Flexibility Analysis ("FRFA") when it adopted part 1112. 78 FR 15836 (Mar. 12, 2013). The FRFA concluded that the accreditation requirements would not have a significant adverse impact on a substantial number of small laboratories because no requirements were imposed on laboratories that did not intend to provide third party testing services. The only laboratories that were expected to provide such services were laboratories that anticipated receiving sufficient revenue from the mandated testing to justify accepting the requirements as a business decision.

For the same reasons, including the NOR for high chairs in part 1112 would not have a significant adverse impact on small laboratories. Moreover, CPSC expects that only a small number of laboratories would request accreditation to test high chairs, based on the number of laboratories that have applied for CPSC accreditation to test for conformance to other juvenile product standards. Most laboratories would already have accreditation to test for conformance to other juvenile product standards, and then the only costs would be to add the high chair standard to their scope of accreditation. Test laboratories have indicated that this cost is extremely low when they are already accredited for other CPSIA section 104 rules. Therefore, the Commission certifies that the NOR for the high chair standard will not have a significant impact on a substantial number of small entities.

#### G. Alternatives

At least four alternatives are available to minimize the economic impact on small entities supplying high chairs while also complying with the direction of section 104 of the CPSIA: (1) Adopt ASTM F404-15 with no modifications; (2) adopt ASTM F404-15 with the proposed modifications, except for requirements on the placement of warning labels; (3) adopt ASTM F404-

15 with the proposed modifications, but exclude restaurant-style high chairs from the scope of the rule; and (4) provide a later effective date for some or all high chairs.

First, section 104 of the CPSIA directs the Commission to promulgate a standard that is either substantially the same as the voluntary standard or more stringent if the Commission determines that would further reduce the risk of injury associated with the product. Therefore, adopting ASTM F404-15 with no modifications is the least stringent rule CPSC could adopt. This alternative would reduce the economic impact on all of the small businesses supplying high chairs to the U.S. market. Although, choosing this alternative would not reduce the testing costs associated with the rule, this option would eliminate the economic impact of complying with the requirements that CPSC proposes in addition to ASTM F404-15 for many firms. Specifically, this option would eliminate the cost of complying with the additional requirements for the 10 small domestic manufacturers and 9 small importers and wholesalers with compliant high chairs, all of whom would likely comply with ASTM F404-15 by the time a CPSC final rule for high chairs would take effect. However, the requirements that CPSC proposes in addition to ASTM F404-15 would reduce the risk of injuries associated with backward tip-over incidents and fall incidents where caregivers did not use restraints or used the restraints improperly. Adopting ASTM F404-15 with no modifications would not meet these objectives.

Second, the Commission could reduce impacts to small businesses by adopting ASTM F404-15 with the proposed modifications, except for the requirement regarding the placement and visibility requirements for warning labels. One option is to require warning labels to be visible only as a child is being placed into the high chair. This would reduce the proportion of high chair models with backs that would need to be redesigned and expanded to accommodate labels that are visible when the high chair is occupied. Another option would be to allow duplicate labels. Manufacturers could place one label on the front seat back, which would be visible when the child is placed in the seat, and manufacturers could place a second label in a location that is visible when the child is in the high chair. This alternative would reduce the economic impact on compact high chairs or high chairs with smaller backs.

Third, because a substantial portion of the economic impact of the proposed rule would fall on small, restaurant-style high chair suppliers, CPSC could exclude restaurant-style high chairs from this rule. Restaurant settings have unique requirements, including a need for smaller high chairs and to accommodate children of various sizes. It would be difficult to retain these features and comply with the proposed requirements. Moreover, CPSC has identified only a few injuries that involved high chairs in restaurant settings. Therefore, the reduction in safety benefits associated with limiting the rule's scope likely would be minimal.

If restaurants could no longer provide high chairs with the desirable attributes, restaurants may stop providing high chairs for customers, which could result in customers using less safe options, such as placing infant carriers on tables or chairs, or using booster seats for children under the appropriate age. CPSC requests comments on the potential impact of excluding restaurant-style high chairs from the proposed rule, including cost and safety impacts.

Because restaurant-style high chairs are also available to consumers for home use, CPSC could take steps to reduce the potential safety risks of these high chairs through other means. For example, CPSC could require restaurant-style high chair suppliers to label their products: "not intended for home use." Additionally, CPSC could develop separate warning label requirements for these products to inform users of the specific hazard patterns related to restaurant-style high chairs. ASTM could also develop requirements specific to restaurant-style high chairs. CPSC requests comments on the possibility of excluding restaurant-style high chairs from the proposed requirements, including the implications for safety and costs.

Fourth, the Commission could reduce the economic impact of the proposed rule on small businesses by setting a later effective date for some or all high chairs. A later effective date would reduce the economic impact on firms in two ways. First, firms would be less likely to experience a lapse in production or imports that could result if they are unable to come into compliance and secure third party testing within the required timeframe. Second, firms could spread costs over a longer period, thereby reducing annual costs, as well as the present value of total costs. CPSC requests comments on the 6-month effective date, as well as feedback on how firms likely would

address the proposed rule. CPSC could also consider a longer effective date for firms that supply restaurant-style high chairs. However, this may not reduce the economic impact on these firms because the primary cost issue for them is the utility of their high chairs, not the time needed to comply with the standard. Nevertheless, CPSC requests comments, particularly from restaurants and other commercial establishments, on the validity of this conclusion.

**XIII. Environmental Considerations**

The Commission’s regulations outline the types of agency actions that require an environmental assessment (“EA”) or environmental impact statement (“EIS”). Rules that have “little or no potential for affecting the human environment” fall within a “categorical exclusion” under the National Environmental Policy Act (“NEPA”; 42 U.S.C. 4231–4370h) and the regulations implementing NEPA (40 CFR parts 1500–1508) and do not normally require an EA or EIS. As stated in 16 CFR 1021.5(c)(1), rules or safety standards

that provide design or performance requirements for products fall within that categorical exclusion. Because this proposed rule would create design and performance requirements for high chairs, the proposed rule falls within the categorical exclusion, and thus, no EA or EIS is required.

**XIV. Paperwork Reduction Act**

This proposed rule contains information collection requirements that are subject to public comment and review by the Office of Management and Budget (“OMB”) under the Paperwork Reduction Act of 1995 (“PRA”; 44 U.S.C. 3501–3521). Under 44 U.S.C. 3507(a)(1)(D), an agency must publish the following information:

- a title for the collection of information;
- a summary of the collection of information;
- a brief description of the need for the information and the proposed use of the information;
- a description of the likely respondents and proposed frequency of

response to the collection of information;

- an estimate of the burden that shall result from the collection of information; and
- notice that comments may be submitted to OMB.

In accordance with this requirement, the Commission provides the following information:

*Title:* Safety Standard for High Chairs

*Description:* The proposed rule would require each high chair to comply with ASTM F404–15, with additional requirements regarding rearward stability and warnings in labels and instructional literature. Sections 8 and 9 of ASTM F404–15 contain requirements for labels and instructional literature. These requirements fall within the definition of “collection of information” provided in the PRA at 44 U.S.C. 3502(3).

*Description of Respondents:* Persons who manufacture or import high chairs.

*Estimated Burden:* CPSC estimates the burden of this collection of information as follows:

TABLE 4—ESTIMATED ANNUAL REPORTING BURDEN

16 CFR section	Number of respondents	Frequency of responses	Total annual responses	Hours per response	Total burden hours
1231.2 .....	62	2	124	1	124

CPSC’s estimate is based on the following:

Section 8.1 of ASTM F404–15 requires that the name and address (city, state, and zip code) of the manufacturer, distributor, or seller be marked on each high chair. Section 8.2 of ASTM F404–15 requires a code mark or other product identification on each high chair and the high chair’s package that indicates the date (month and year) of manufacture.

Sixty-two known entities supply high chairs to the U.S. market and may need to modify their existing labels to comply with ASTM F404–15. CPSC estimates that the time required to make these modifications is about 1 hour per model. Based on an evaluation of supplier product lines, each entity supplies an average of two models of high chairs. Therefore, the estimated burden associated with labels is 1 hour per model × 62 entities × 2 models per entity = 124 hours. CPSC estimates the hourly compensation for the time required to create and update labels is \$30.19 (U.S. Bureau of Labor Statistics, “Employer Costs for Employee Compensation,” Mar. 2015, Table 9, total compensation for all sales and office workers in goods-producing

private industries: <http://www.bls.gov/ncs/>). Therefore, the estimated annual cost associated with the proposed labeling requirements is \$3,743.56 (\$30.19 per hour × 124 hours = \$3,743.56). No operating, maintenance, or capital costs are associated with the collection.

Section 9.1 of ASTM F404–15 requires instructions to be supplied with a high chair. High chairs are products that generally require use and assembly instructions. As such, high chairs sold without use and assembly instructions would not be able to compete successfully with high chairs that supply this information. Under OMB’s regulations, the time, effort, and financial resources necessary to comply with a collection of information incurred by parties in the “normal course of their activities” are excluded from a burden estimate when an agency demonstrates that the disclosure activities required are “usual and customary.” 5 CFR 1320.3(b)(2). CPSC is unaware of high chairs that generally require use or assembly instructions but lack such instructions. Therefore, CPSC estimates that no burden hours are associated with section 9.1 of ASTM F404–15, because any burden associated

with supplying instructions with high chairs would be “usual and customary,” and thus, excluded from “burden” estimates under OMB’s regulations.

Based on this analysis, the proposed standard for high chairs would impose a burden to industry of 124 hours at a cost of \$3,743.56 annually.

CPSC has submitted the information collection requirements of this rule to OMB for review in accordance with PRA requirements. 44 U.S.C. 3507(d). CPSC requests interested parties submit comments regarding information collection to the Office of Information and Regulatory Affairs, OMB (see the ADDRESSES section at the beginning of this notice). Pursuant to 44 U.S.C. 3506(c)(2)(A), the Commission invites comments on:

- whether the proposed collection of information is necessary for the proper performance of CPSC’s functions, including whether the information will have practical utility;
- the accuracy of CPSC’s estimate of the burden of the proposed collection of information, including the validity of the methodology and assumptions used;
  - ways to enhance the quality, utility, and clarity of the information the Commission proposes to collect;

- ways to reduce the burden of the collection of information on respondents, including the use of automated collection techniques, when appropriate, and other forms of information technology; and
- the estimated burden hours associated with modifying labels and instructional literature, including any alternative estimates.

### XV. Preemption

Under section 26(a) of the CPSA, no state or political subdivision of a state may establish or continue in effect a requirement dealing with the same risk of injury as a federal consumer product safety standard under the CPSA unless the state requirement is identical to the federal standard. 15 U.S.C. 2075(a). States or political subdivisions of states may, however, apply to the Commission for an exemption, allowing them to establish or continue such a requirement if the state requirement provides a significantly high degree of protection from the risk of injury and does not unduly burden interstate commerce. *Id.* at 2075(c).

One of the functions of the CPSIA was to amend the CPSA, adding several provisions to CPSA, including CPSIA section 104 in 15 U.S.C. 2056a. As such, consumer product safety standards that the Commission creates under CPSIA section 104 are covered by the preemption provision in the CPSA. Consequently, the rule proposed in this NPR would be a federal consumer product safety standard, and the preemption provision in section 26 of the CPSA would apply.

### XVI. Request for Comments

This NPR begins a rulemaking proceeding under section 104(b) of the CPSIA to issue a consumer product safety standard for high chairs and to amend part 1112 to add high chairs to the list of children's product safety rules for which CPSC has issued an NOR. We invite all interested persons to submit comments on any aspect of the proposed mandatory safety standard for high chairs and on the proposed amendment to part 1112. Specifically, the Commission requests comments on the following:

- the requirements in ASTM F404–15, including their effectiveness in addressing the risk of injury associated with high chairs and the costs of complying with these requirements;
- the additional requirements proposed for rearward stability, including its effectiveness in addressing the risk of injury associated with rearward tip-overs and the costs of complying with these requirements;

- the additional requirements proposed for warnings in labels and instructional literature, including their effectiveness at addressing the risk of injury associated with falls from high chairs and the costs of complying with these requirements;
- whether application of different requirements to restaurant-style high chairs is appropriate, relevant safety implications, and options for applying distinct standards;
- the costs to small businesses associated with the requirements proposed in this NPR, including the costs to comply with the proposed rearward stability requirements, content and form requirements for labels and instructional literature, and placement requirements for labels;
- alternatives to the proposed standard that would reduce impacts on small businesses;
- the proposed effective date and whether an extended effective date would further mitigate the impact on small businesses and to what extent; and
- any additional information relevant to the issues discussed in this NPR and the proposed requirements.

During the comment period, ASTM F404–15 is available for review. Please see section X. for instructions on viewing it.

Please submit comments in accordance with the instructions in the **ADDRESSES** section at the beginning of this NPR.

#### List of Subjects

##### 16 CFR Part 1112

Administrative practice and procedure, Audit, Consumer protection, Reporting and recordkeeping requirements, Third party conformity assessment body.

##### 16 CFR Part 1231

Consumer protection, Imports, Incorporation by reference, Infants and children, Labeling, Law enforcement, and Toys.

For the reasons discussed in the preamble, the Commission proposes to amend Title 16 of the Code of Federal Regulations as follows:

### PART 1112—REQUIREMENTS PERTAINING TO THIRD PARTY CONFORMITY ASSESSMENT BODIES

■ 1. The authority citation for part 1112 continues to read as follows:

**Authority:** Pub. L. 110–314, section 3, 122 Stat. 3016, 3017 (2008); 15 U.S.C. 2063.

■ 2. Amend § 1112.15 by adding paragraph (b)(44) to read as follows:

### § 1112.15 When can a third party conformity assessment body apply for CPSC acceptance for a particular CPSC rule or test method?

\* \* \* \* \*

(b) \* \* \*

(44) 16 CFR part 1231, Safety Standard for High Chairs.

\* \* \* \* \*

■ 3. Add part 1231 to read as follows:

### PART 1231—SAFETY STANDARD FOR HIGH CHAIRS

Sec.

1231.1 Scope.

1231.2 Requirements for high chairs.

**Authority:** The Consumer Product Safety Improvement Act of 2008, Pub. L. 110–314, § 104, 122 Stat. 3016 (August 14, 2008); Pub. L. 112–28, 125 Stat. 273 (August 12, 2011).

#### § 1231.1 Scope.

This part establishes a consumer product safety standard for high chairs.

#### § 1231.2 Requirements for high chairs.

(a) Except as provided in paragraphs (b) through (e) of this section, each high chair must comply with all applicable provisions of ASTM F404–15, Standard Consumer Safety Specification for High Chairs, approved on May 15, 2015. The Director of the Federal Register approves this incorporation by reference in accordance with 5 U.S.C. 552(a) and 1 CFR part 51. You may obtain a copy from ASTM International, 100 Bar Harbor Drive, P.O. Box 0700, West Conshohocken, PA 19428; <http://www.astm.org/cpsc.htm>. You may inspect a copy at the Office of the Secretary, U.S. Consumer Product Safety Commission, Room 820, 4330 East West Highway, Bethesda, MD 20814, telephone 301–504–7923, or at the National Archives and Records Administration (NARA). For information on the availability of this material at NARA, call 202–741–6030, or go to: [http://www.archives.gov/federal\\_register/code\\_of\\_federal\\_regulations/ibr\\_locations.html](http://www.archives.gov/federal_register/code_of_federal_regulations/ibr_locations.html).

(b) Instead of complying with section 6.5 of ASTM F404–15, comply with the following:

(1) 6.5.1 *Forward and sideways stability*—A chair shall not tip over when forces are applied in accordance with 7.7.2.4 and 7.7.2.5.

(2) 6.5.2 *Rearward stability*—When tested in accordance with 7.7.2.6 (paragraph (c)(3) of this section), a high chair shall not have a Rearward Stability Index of 50 or more.

(c) For rearward stability testing, instead of complying with sections 7.7.2.1, 7.7.2.2, and 7.7.2.6 of ASTM F404–15, comply with the following:

(1) 7.7.2.1 Place the high chair in a manufacturer's recommended use position with all legs on a level floor and with the seat back adjusted into the most upright position. Attach the tray in the rear position, closest to the high chair seat back. For high chairs with height-adjustable seats, adjust the seat into the highest manufacturer's recommended use position or the position deemed most likely to fail. If a high chair has lockable wheels, those

wheels shall be locked during stability testing.

(2) 7.7.2.2 Place the high chair on a rigid, horizontal test surface covered with 60 grit sandpaper or equivalent to prevent the chair from sliding on the test surface during the test. If a high chair slides on the test surface during the test or has wheels that do not lock, place a stop on the test surface to prevent sliding during the test. The stop shall be low profile, minimum height required to prevent sliding, and shall

not inhibit the tipping of the high chair or affect the test results.

(3) 7.7.2.6 *Rearward stability*—

(i) 7.7.2.6.1 Attach a force gauge to the rear surface of the seat back at the lateral centerline and 7 ¼ in. (184 mm) above the occupant seating surface as shown in Figure 1. For high chairs with a seat back 7 ¼ in. (184 mm) high or less, attach the force gauge at the lateral centerline and top surface of the seat back.

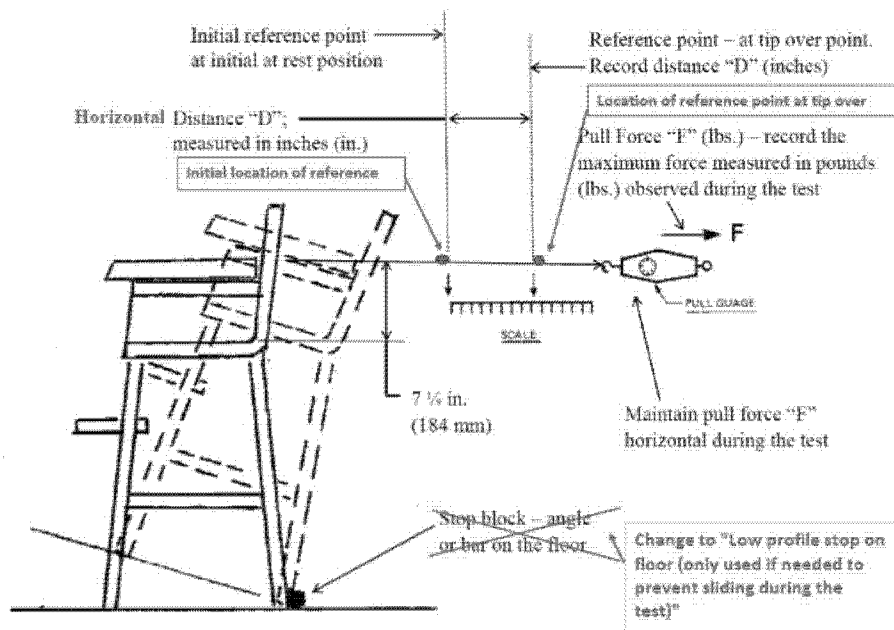

FIGURE 1.—Rearward Stability Test

(ii) 7.7.2.6.2 With the high chair in the at rest position, gradually apply a preload force “F” of 3 lbf (13 N) to the seat back surface of the high chair and while maintaining the force, establish the initial location of a reference point some distance away from the force gauge as shown in Figure 1.

(iii) 7.7.2.6.3 Gradually increase the horizontal force over a period of at least 5 seconds and continue to pull the high chair rearward until the high chair reaches the point that it becomes unstable and is on the verge of tipping over. Record the maximum force “F” in pounds (lbs.) applied during the test and the horizontal distance “D” in inches (in.) from the initial location of the reference point to the location of the reference point where the high chair becomes unstable and is on the verge of tipping over. Force “F” shall be maintained in a horizontal direction throughout the test.

(iv) 7.7.2.6.4 Calculate the Rearward Stability Index using the formula shown below.

Rearward Stability Index =  $2F + D$   
Force “F” is measured in pounds (lbs.).  
Distance “D” in measured in inches (in.)

(d) Instead of complying with section 8.4 of ASTM F404–15, comply with the following:

(1) 8.4 *Warning Statements—Each Product Shall Have Warning Statements:*

(i) 8.4.1 The warnings shall be easy to read and understand and be in the English language at a minimum.

(ii) 8.4.2 Any labels or written instructions provided in addition to those required by this section shall not contradict or confuse the meaning of the required information, or be otherwise misleading to the consumer.

(iii) 8.4.3 The warning statements shall be conspicuous, in highly contrasting color(s) (e.g., black text on a white background), permanent, and in non-condensed sans serif style type.

(iv) 8.4.4 Each warning statement or group of warning statements shall be preceded by the Safety Alert Symbol



and the signal word “WARNING” in bold uppercase letters. If warnings are placed directly under or adjacent to one another, then the safety alert symbol and the signal word WARNING need to be displayed only once. The Safety Alert Symbol



and the signal word “WARNING” shall not be less than 0.2 in. (5 mm) high and the remainder of the text shall be in characters whose uppercase shall not be less than 0.1 in. (2.5 mm) high. The height of the safety alert symbol shall equal or exceed the signal word height.

(v) 8.4.5 The safety alert symbol



and the signal word “WARNING” shall be in contrasting color to the background and delineated with solid black line borders. The background color behind the safety alert symbol



and the signal word “WARNING” shall be orange, red, or yellow, whichever provides the best contrast against the

product background. The signal word “WARNING” and the solid triangle portion of the safety alert symbol



shall be black. The exclamation mark of the safety alert symbol



shall be the same color as the background. The remainder of the text

shall be black, with key words highlighted using boldface, on a white background surrounded by a solid black line border. This text also shall be left-justified, in upper and lowercase letters (*i.e.*, sentence capitalization), and in list or outline format, with precautionary statements indented from hazard statements and preceded with bullet points. An example label in the format described in this section is shown in Figure 2.

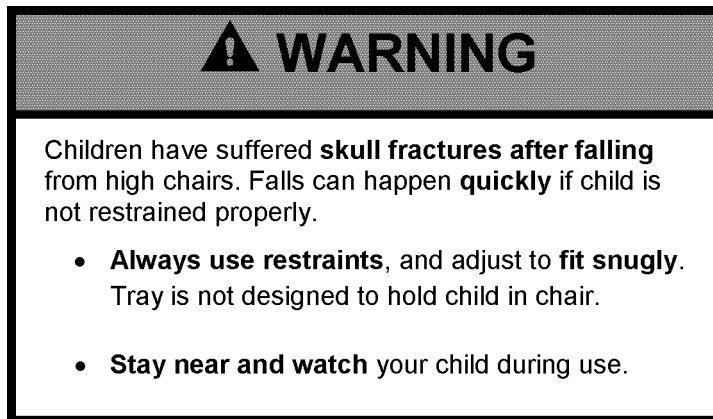

FIGURE 2.—Label Format Example

**Note:** For optional additional guidance on the design of warnings, see the most-recent edition of ANSI Z535.4, *Product Safety Signs and Labels*, American National Standards Institute, Inc., available at <http://www.ansi.org/>.

(vi) 8.4.6 The warning statements shall be in a location that is visible by the caregiver while placing the occupant into the high chair in each of the manufacturer’s recommended use positions.

(vii) 8.4.7 High chairs that do not have a seating component that is also used as a seating component of a stroller, shall, in the same label, address the following warning statements:

Children have suffered skull fractures after falling from high chairs. Falls can happen quickly if child is not restrained properly.

- Always use restraints, and adjust to fit snugly. Tray is not designed to hold child in chair.
- Stay near and watch your child during use.

(viii) 8.4.8 High chairs that have a seating component that is also used as a seating component of a stroller shall use the warning statements as specified in subsections 8.2.2.1 and 8.2.2.2 of the version of the standard that is incorporated by reference in part 1227 of this subchapter, in place of the

warning statements in 8.4.7 (paragraph (d)(vii) of this section).

(e) Instead of complying with section 9.2 of ASTM F404–15, comply with the following:

(1) 9.2 The instructions shall contain the warnings as specified in section 8.4 (paragraph (d)(1) of this section). Additional warnings similar to the statements included in this section shall also be included. These required warning statements shall meet the requirements described in section 8.4 (paragraph (d)(1) of this section), except for the color requirements (*i.e.*, the background of the signal word panel need not be orange, red, or yellow). However, the warning statements still must be in highly contrasting color(s) (*e.g.*, black text on a white background), and if color is used, those colors must meet the color requirements specified in section 8.4 (paragraph (d)(1) of this section).

(2) Reference to section 9.2 of ASTM F404–15 in paragraph (e) of this section includes only the introductory paragraph of section 9.2 and does not include subsections 9.2.1 or 9.2.2 of ASTM F404–15.

**Note:** For optional additional guidance on the design of warnings for instructional literature, see the most-recent addition of ANSI Z535.6, *Product Safety Information in*

*Product Manuals, Instructions, and Other Collateral Materials*, American National Standards Institute, Inc., available at <http://www.ansi.org/>.

Dated: November 2, 2015.

**Todd A. Stevenson,**  
Secretary, Consumer Product Safety Commission.

[FR Doc. 2015–28300 Filed 11–6–15; 8:45 am]

BILLING CODE 6355–01–P

## DEPARTMENT OF THE INTERIOR

### Bureau of Indian Affairs

#### 25 CFR Part 30

[167 A2100DD/AAKC001030/  
AOA501010.999900]

#### Notice of Intent To Establish a Negotiated Rulemaking Committee

**AGENCY:** Bureau of Indian Education, Interior.

**ACTION:** Notice of intent; request for nominations for tribal representatives; and comments.

**SUMMARY:** The Bureau of Indian Education (BIE) is announcing its intent to establish an Accountability Negotiated Rulemaking Committee (Committee). The Committee will