

will update this part in 2026 and every three years thereafter to reflect the new amount.

\* \* \* \* \*

## PART 2635—STANDARDS OF ETHICAL CONDUCT FOR EMPLOYEES OF THE EXECUTIVE BRANCH

■ 4. The authority citation for part 2635 continues to read as follows:

**Authority:** 5 U.S.C. 7301, 7351, 7353; 5 U.S.C. App. (Ethics in Government Act of 1978); E.O. 12674, 54 FR 15159, 3 CFR, 1989 Comp., p. 215, as modified by E.O. 12731, 55 FR 42547, 3 CFR, 1990 Comp., p. 306.

### § 2635.204 [Amended]

■ 5. In § 2635.204, in paragraph (g)(3)(iv) and examples 1 and 4 to paragraph (g), remove the dollar amount “\$415” and add in its place “\$480”.

[FR Doc. 2023-12291 Filed 6-8-23; 8:45 am]

BILLING CODE 6345-03-P

## DEPARTMENT OF TRANSPORTATION

### Federal Aviation Administration

#### 14 CFR Part 39

[Docket No. FAA-2023-1055; Project Identifier AD-2023-00583-T; Amendment 39-22445; AD 2023-10-09]

RIN 2120-AA64

### Airworthiness Directives; The Boeing Company Airplanes

**AGENCY:** Federal Aviation Administration (FAA), DOT.

**ACTION:** Final rule; request for comments.

**SUMMARY:** The FAA is adopting a new airworthiness directive (AD) for all The Boeing Company Model 787-8, 787-9, and 787-10 airplanes. This AD was prompted by reports of damaged decompression panels from operators. This AD requires repetitive inspections for damaged fastener holes on the vertical and bottom edges of the inward and outward blowing decompression panels installed on the forward and aft cargo compartment vertical sidewall linings and applicable on-condition actions. The FAA is issuing this AD to address the unsafe condition on these products.

**DATES:** This AD is effective June 26, 2023.

The FAA must receive comments on this AD by July 24, 2023.

**ADDRESSES:** You may send comments, using the procedures found in 14 CFR 11.43 and 11.45, by any of the following methods:

- *Federal eRulemaking Portal:* Go to [regulations.gov](https://www.regulations.gov). Follow the instructions for submitting comments.

- *Fax:* 202-493-2251.

- *Mail:* U.S. Department of Transportation, Docket Operations, M-30, West Building Ground Floor, Room W12-140, 1200 New Jersey Avenue SE, Washington, DC 20590.

- *Hand Delivery:* Deliver to Mail address above between 9 a.m. and 5 p.m., Monday through Friday, except Federal holidays.

*AD Docket:* You may examine the AD docket at [regulations.gov](https://www.regulations.gov) by searching for and locating Docket No. FAA-2023-1055; or in person at Docket Operations between 9 a.m. and 5 p.m., Monday through Friday, except Federal holidays. The AD docket contains this final rule, any comments received, and other information. The street address for Docket Operations is listed above.

#### FOR FURTHER INFORMATION CONTACT:

Nicole S. Tsang, Aviation Safety Engineer, FAA, 2200 South 216th St., Des Moines, WA 98198; telephone: 206-231-3959; email: [Nicole.S.Tsang@faa.gov](mailto:Nicole.S.Tsang@faa.gov).

#### SUPPLEMENTARY INFORMATION:

##### Background

The FAA has received a report indicating operators have found damaged fastener holes on vertical sidewall decompression panels installed in the forward and aft cargo compartments (*i.e.*, cargo liner panel). These decompression panels are designed to open only during a decompression event and otherwise remain sealed. Damaged fastener holes that exceed the allowable damage limits or fastener holes that are folded back during installation could result in movement of the decompression panel affecting the seal. This could result in possible leakage in the cargo compartments, which in the event of a cargo fire, could lead to insufficient Halon concentrations to adequately control the fire. This condition, if not addressed, could result in the loss of continued safe flight and landing of the airplane. The FAA is issuing this AD to address the unsafe condition on these products.

##### FAA's Determination

The FAA is issuing this AD because the agency has determined the unsafe condition described previously is likely to exist or develop in other products of the same type design.

##### AD Requirements

This AD requires gaining access to the fastener holes on the vertical and

bottom edges of the inward and outward blowing decompression panels installed on the forward and aft cargo compartment vertical sidewall linings; repetitive general visual inspections of those fastener holes for damage (such as a tear, cut, split, puncture, or delamination) and applicable on-condition actions; and making sure the panel fastener holes are not folded back when installing the decompression panel after completing the general visual inspection. On-condition actions include replacement of any decompression panel having damaged fastener holes that exceed the allowable damage limits with a serviceable panel. The allowable damage limits are as follows: damage on a fastener hole must not extend beyond the width of the fastener hole; if the damage is on one side of the fastener hole and the other side of the fastener hole has no damage, the damage must not extend more than the diameter of the fastener hole; the decompression panel must not have more than two adjacent damaged fastener holes with damage; and the decompression panel must not have more than four damaged fastener holes. For the purposes of this AD, a serviceable panel is one that has not exceeded the allowable damage limits. A decompression panel repaired using a method approved by The Boeing Company Organization Designation Authorization (ODA) is considered serviceable.

##### Minimum Equipment List (MEL) Provision

Paragraph (j) of this AD specifies that if any decompression panel is damaged and the decompression panel is deemed not serviceable, the airplane may be operated as specified in the operator's FAA-approved MEL, provided provisions that address the damaged decompression panel are included in the MEL.

##### Interim Action

The FAA considers this AD to be an interim action. If final action is later identified, the FAA might consider further rulemaking then.

##### Justification for Immediate Adoption and Determination of the Effective Date

Section 553(b)(3)(B) of the Administrative Procedure Act (APA) (5 U.S.C. 551 *et seq.*) authorizes agencies to dispense with notice and comment procedures for rules when the agency, for “good cause,” finds that those procedures are “impracticable, unnecessary, or contrary to the public interest.” Under this section, an agency, upon finding good cause, may issue a

final rule without providing notice and seeking comment prior to issuance. Further, section 553(d) of the APA authorizes agencies to make rules effective in less than thirty days, upon a finding of good cause.

An unsafe condition exists that requires the immediate adoption of this AD without providing an opportunity for public comments prior to adoption. The FAA has found that the risk to the flying public justifies forgoing notice and comment prior to adoption of this rule because significant leakage in the cargo compartments, in the event of a cargo fire, could lead to insufficient Halon concentrations to adequately control the fire. This condition, if not addressed, could result in loss of continued safe flight and landing of the airplane. Since this issue significantly compromises the fire suppression system, which is a required safety feature for extended operations (ETOPS) flights, the FAA finds this unsafe condition to be an urgent safety issue. In addition, the compliance time for the required action is shorter than the time necessary for the public to comment and for publication of the final rule. Accordingly, notice and opportunity for prior public comment are impracticable and contrary to the public interest pursuant to 5 U.S.C. 553(b)(3)(B).

In addition, the FAA finds that good cause exists pursuant to 5 U.S.C. 553(d) for making this amendment effective in less than 30 days, for the same reasons

the FAA found good cause to forgo notice and comment.

**Comments Invited**

The FAA invites you to send any written data, views, or arguments about this final rule. Send your comments to an address listed under **ADDRESSES**. Include Docket No. FAA-2023-1055 and Project Identifier AD-2023-00583-T at the beginning of your comments. The most helpful comments reference a specific portion of the final rule, explain the reason for any recommended change, and include supporting data. The FAA will consider all comments received by the closing date and may amend this final rule because of those comments.

Except for Confidential Business Information (CBI) as described in the following paragraph, and other information as described in 14 CFR 11.35, the FAA will post all comments received, without change, to *regulations.gov*, including any personal information you provide. The agency will also post a report summarizing each substantive verbal contact received about this final rule.

**Confidential Business Information**

CBI is commercial or financial information that is both customarily and actually treated as private by its owner. Under the Freedom of Information Act (FOIA) (5 U.S.C. 552), CBI is exempt from public disclosure. If your comments responsive to this AD contain

commercial or financial information that is customarily treated as private, that you actually treat as private, and that is relevant or responsive to this AD, it is important that you clearly designate the submitted comments as CBI. Please mark each page of your submission containing CBI as "PROPIN." The FAA will treat such marked submissions as confidential under the FOIA, and they will not be placed in the public docket of this AD. Submissions containing CBI should be sent to Nicole S. Tsang, Aviation Safety Engineer, FAA, 2200 South 216th St., Des Moines, WA 98198; telephone: 206-231-3959; email: *Nicole.S.Tsang@faa.gov*. Any commentary that the FAA receives that is not specifically designated as CBI will be placed in the public docket for this rulemaking.

**Regulatory Flexibility Act**

The requirements of the Regulatory Flexibility Act (RFA) do not apply when an agency finds good cause pursuant to 5 U.S.C. 553 to adopt a rule without prior notice and comment. Because the FAA has determined that it has good cause to adopt this rule without notice and comment, RFA analysis is not required.

**Costs of Compliance**

The FAA estimates that this AD affects 152 airplanes of U.S. registry. The FAA estimates the following costs to comply with this AD:

**ESTIMATED COSTS**

Action	Labor cost	Parts cost	Cost per product	Cost on U.S. operators
Repetitive Inspection .....	8 work-hours × \$85 per hour = \$680 per inspection cycle.	\$0	\$680 per inspection cycle .....	\$103,360 per inspection cycle

The FAA estimates the following costs to do any necessary replacement that would be required based on the

results of the inspection. The FAA has no way of determining the number of

aircraft that might need this replacement:

**ON-CONDITION COSTS**

Action	Labor cost	Parts cost	Cost per product
Replacement .....	1 work-hour × \$85 per hour = \$85 .....	\$0	\$85

\* The FAA has received no definitive data for the parts cost on which to base the cost estimate for the on-condition replacement specified in this AD. There are 19 panels on each airplane.

**Authority for This Rulemaking**

Title 49 of the United States Code specifies the FAA's authority to issue rules on aviation safety. Subtitle I, section 106, describes the authority of the FAA Administrator. Subtitle VII: Aviation Programs describes in more

detail the scope of the Agency's authority.

The FAA is issuing this rulemaking under the authority described in Subtitle VII, Part A, Subpart III, Section 44701: General requirements. Under that section, Congress charges the FAA

with promoting safe flight of civil aircraft in air commerce by prescribing regulations for practices, methods, and procedures the Administrator finds necessary for safety in air commerce. This regulation is within the scope of that authority because it addresses an

unsafe condition that is likely to exist or develop on products identified in this rulemaking action.

### Regulatory Findings

This AD will not have federalism implications under Executive Order 13132. This AD will not have a substantial direct effect on the States, on the relationship between the national government and the States, or on the distribution of power and responsibilities among the various levels of government.

For the reasons discussed above, I certify that this AD:

(1) Is not a “significant regulatory action” under Executive Order 12866, and

(2) Will not affect intrastate aviation in Alaska.

### List of Subjects in 14 CFR Part 39

Air transportation, Aircraft, Aviation safety, Incorporation by reference, Safety.

### The Amendment

Accordingly, under the authority delegated to me by the Administrator, the FAA amends 14 CFR part 39 as follows:

### PART 39—AIRWORTHINESS DIRECTIVES

■ 1. The authority citation for part 39 continues to read as follows:

**Authority:** 49 U.S.C. 106(g), 40113, 44701.

### § 39.13 [Amended]

■ 2. The FAA amends § 39.13 by adding the following new airworthiness directive:

**2023–10–09 The Boeing Company:**  
Amendment 39–22445; Docket No. FAA–2023–1055; Project Identifier AD–2023–00583–T.

#### (a) Effective Date

This airworthiness directive (AD) is effective June 26, 2023.

#### (b) Affected ADs

None.

#### (c) Applicability

This AD applies to all The Boeing Company Model 787–8, 787–9, and 787–10 airplanes, certificated in any category.

#### (d) Subject

Air Transport Association (ATA) of America Code 26, Fire Protection.

#### (e) Unsafe Condition

This AD was prompted by a report indicating operators have found damaged fastener holes on vertical sidewall decompression panels installed in the forward and aft cargo compartments (*i.e.*, cargo liner panel). The FAA is issuing this AD to address the possibility of leakage in the cargo compartments, which in the event of a cargo fire, could lead to insufficient Halon concentrations to adequately control the fire. The unsafe condition, if not addressed, could result in the loss of continued safe flight and landing of the airplane.

#### (f) Compliance

Comply with this AD within the compliance times specified, unless already done.

### (g) Definitions

For the purposes of this AD, the following terms are defined as follows.

(1) A “general visual inspection” is a visual examination of an interior or exterior area, installation, or assembly to detect obvious damage, failure, or irregularity. This level of inspection is made from within touching distance, unless otherwise specified. A mirror may be necessary to enhance visual access to all exposed surfaces in the inspection area. This level of inspection is made under normally available lighting conditions such as daylight, hangar lighting, flashlight, or drop-light and may require removal or opening of access panels or doors. Stands, ladders, or platforms may be required to gain proximity to the area being checked. Basic cleaning may be required to ensure appropriate visibility.

(2) A “damaged fastener hole” is a fastener hole having damage such as a tear, cut, split, puncture, or delamination.

(3) A “serviceable panel” is a decompression panel that has not exceeded the allowable damage limits specified in paragraphs (g)(3)(i) through (iv) of this AD. A decompression panel repaired using a method approved by The Boeing Company Organization Designation Authorization (ODA) is considered serviceable.

(i) If the damage is on the fastener hole, the damage must not extend beyond the width of the fastener hole. Refer to figure 1 to paragraph (g)(3)(i) of this AD. Where figure 1 to paragraph (g)(3)(i) of this AD refers to tears or tearing, this includes all types of damage as defined in paragraph (g)(2) of this AD.

**BILLING CODE 4910–13–P**

Figure 1 to paragraph (g)(3)(i)—Allowable damage not extending beyond fastener hole width

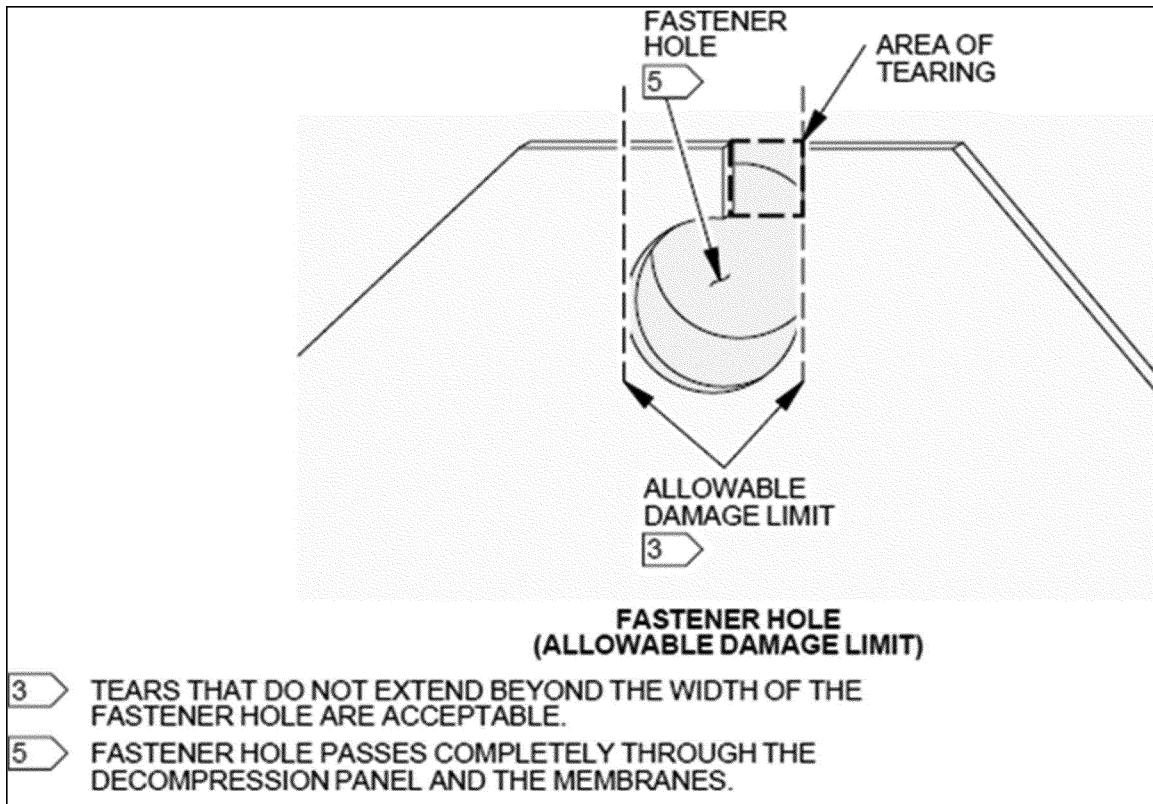

(ii) If the damage is on one side of the fastener hole and the other side of the fastener hole has no damage, the damage must not extend more than the diameter of

the fastener hole. Refer to figure 2 to paragraph (g)(3)(ii) of this AD. Where figure 2 to paragraph (g)(3)(ii) of this AD refers to tears, tearing, or tearing damage, this

includes all types of damage as defined in paragraph (g)(2) of this AD.

Figure 2 to paragraph (g)(3)(ii)—Allowable damage not extending more than fastener hole diameter

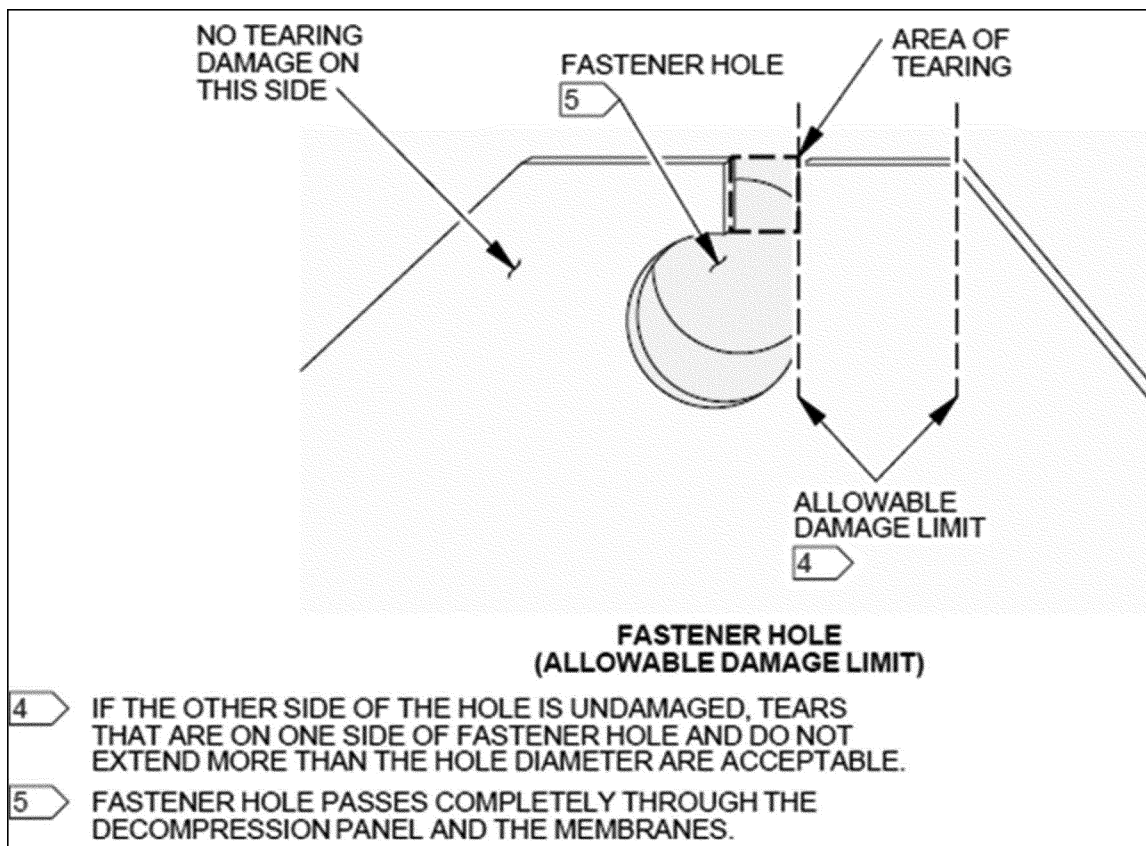

(iii) The decompression panel must not have more than two adjacent damaged fastener holes.

**Note 1 to paragraph (g)(3)(iii):** The limits in paragraphs (g)(3)(iii) and (iv) of this AD refer only to the fastener holes found on the vertical and bottom edges of the decompression panel. These limits do not refer to the fastener holes found on the top edge of the decompression panel.

(iv) The decompression panel must not have more than four damaged fastener holes.

#### (h) Repetitive Inspections

Within 90 days after the effective date of this AD, or within 90 days since the date of issuance of the original airworthiness certificate or date of issuance of the original export certificate of airworthiness, whichever occurs later, accomplish the actions specified in paragraphs (h)(1) and (2) of this AD. Repeat the actions thereafter at intervals not to exceed 90 days.

(1) Gain access to the fastener holes on the vertical and bottom edges of the inward and outward blowing decompression panels installed on the forward and aft cargo compartment vertical sidewall linings.

**Note 2 to paragraph (h)(1):** Additional guidance for gaining access to the fastener holes required by paragraph (h)(1) of this AD and performing the general visual inspection required by paragraph (h)(2) of this AD can be found in Boeing 787 Aircraft Maintenance

Manual (AMM) Task B787-A-50-11-08-02A-280A-A, Lower Cargo Compartment Decompression Panel Inspection.

(2) Do a general visual inspection for any damaged fastener holes.

#### (i) Reinstallation or Replacement

(1) If, during any inspection required by paragraph (h) of this AD, no damaged fastener holes are found or any damaged fastener is found but the decompression panel is deemed serviceable, before further flight, reinstall the decompression panel and make sure the panel fastener holes are not folded back.

**Note 3 to paragraph (i)(1):** Additional guidance for reinstalling the decompression panel required by paragraph (i)(1) of this AD or replacing any damaged panel required by paragraph (i)(2) of this AD can be found in Boeing 787 AMM Task B787-A-50-11-06-03A-520A-A, Forward and Aft Cargo Compartment Vertical Sidewall Lining Removal; and Boeing 787 AMM Task B787-A-50-11-06-03A-720A-A, Forward and Aft Cargo Compartment Vertical Sidewall Lining Installation.

**Note 4 to paragraph (i)(1):** This note applies to paragraphs (i)(1) and (2) of this AD. A folded back panel edge could contribute to inadvertent movement of the decompression panel.

(2) If, during any inspection required by paragraph (h) of this AD, any damaged

fastener hole is found and the decompression panel is deemed not serviceable, before further flight, replace the panel with a serviceable panel, except as provided by paragraph (j) of this AD. Replacement must be done in accordance with the operator's maintenance or inspection program, as applicable. Make sure the panel fastener holes are not folded back when installing the decompression panel.

#### (j) Minimum Equipment List (MEL) Provisions

If any decompression panel inspected as required by paragraph (h)(2) of this AD is damaged and the decompression panel is deemed not serviceable, the airplane may be operated as specified in the operator's FAA-approved MEL, provided provisions that address the damaged decompression panel are included in the MEL.

#### (k) Relief for Maintenance Review Board Report (MRBR) Task

Doing the inspection required by paragraph (h) of this AD is acceptable for compliance to Boeing 787 MRBR Task 50-005-00 (general visual inspection of cargo compartment liners) for inspecting the panel fastener holes required by the existing maintenance or inspection program.

**(l) Alternative Methods of Compliance (AMOCs)**

(1) The Manager, AIR-520 Continued Operational Safety Branch, FAA, has the authority to approve AMOCs for this AD, if requested using the procedures found in 14 CFR 39.19. In accordance with 14 CFR 39.19, send your request to your principal inspector or responsible Flight Standards Office, as appropriate. If sending information directly to the manager of the Continued Operational Safety Branch, send it to the attention of the person identified in paragraph (m)(1) of this AD. Information may be emailed to: *9-ANM-Seattle-ACO-AMOC-Requests@faa.gov*.

(2) Before using any approved AMOC, notify your appropriate principal inspector, or lacking a principal inspector, the manager of the responsible Flight Standards Office.

(3) An AMOC that provides an acceptable level of safety may be used for any repair, modification, or alteration required by this AD if it is approved by The Boeing Company ODA that has been authorized by the Manager, AIR-520 Continued Operational Safety Branch, FAA, to make those findings. To be approved, the repair method, modification deviation, or alteration deviation must meet the certification basis of the airplane, and the approval must specifically refer to this AD.

**(m) Related Information**

(1) For more information about this AD, contact Nicole S. Tsang, Aviation Safety Engineer, FAA, 2200 South 216th St., Des Moines, WA 98198; telephone: 206-231-3959; email: *Nicole.S.Tsang@faa.gov*.

(2) For Boeing service information identified in this AD that is not incorporated by reference, contact Boeing Commercial Airplanes, Attention: Contractual & Data Services (C&DS), 2600 Westminister Blvd., MC 110-SK57, Seal Beach, CA 90740-5600; telephone 562-797-1717; website *myboeingfleet.com*. You may view this service information at the FAA, Airworthiness Products Section, Operational Safety Branch, 2200 South 216th St., Des Moines, WA. For information on the availability of this material at the FAA, call 206-231-3195.

**(n) Material Incorporated by Reference**

None.

Issued on May 24, 2023.

**Michael Linegang,**

*Acting Director, Compliance & Airworthiness Division, Aircraft Certification Service.*

[FR Doc. 2023-12405 Filed 6-7-23; 8:45 am]

**BILLING CODE 4910-13-C**

**DEPARTMENT OF TRANSPORTATION****Federal Aviation Administration****14 CFR Part 39**

**[Docket No. FAA-2023-1205; Project Identifier AD-2023-00441-E; Amendment 39-22452; AD 2023-11-06]**

**RIN 2120-AA64**

**Airworthiness Directives; Engine Alliance Engines**

**AGENCY:** Federal Aviation Administration (FAA), DOT.

**ACTION:** Final rule; request for comments.

**SUMMARY:** The FAA is adopting a new airworthiness directive (AD) for certain Engine Alliance (EA) Model GP7270, GP7272, and GP7277 engines. This AD was prompted by a manufacturer investigation that revealed that certain high-pressure turbine (HPT) interstage seals were manufactured from material suspected to contain iron inclusion. This AD requires replacement of the affected HPT interstage seals. The FAA is issuing this AD to address the unsafe condition on these products.

**DATES:** This AD is effective June 26, 2023.

The FAA must receive comments on this AD by July 24, 2023.

**ADDRESSES:** You may send comments, using the procedures found in 14 CFR 11.43 and 11.45, by any of the following methods:

- *Federal eRulemaking Portal:* Go to *regulations.gov*. Follow the instructions for submitting comments.

- *Fax:* (202) 493-2251.

- *Mail:* U.S. Department of Transportation, Docket Operations, M-30, West Building Ground Floor, Room W12-140, 1200 New Jersey Avenue SE, Washington, DC 20590.

- *Hand Delivery:* Deliver to Mail address above between 9 a.m. and 5 p.m., Monday through Friday, except Federal holidays.

*AD Docket:* You may examine the AD docket at *regulations.gov* by searching for and locating Docket No. FAA-2023-1205; or in person at Docket Operations between 9 a.m. and 5 p.m., Monday through Friday, except Federal holidays. The AD docket contains this final rule, any comments received, and other information. The street address for Docket Operations is listed above.

**FOR FURTHER INFORMATION CONTACT:**

Alexei Marqueen, Aviation Safety Engineer, FAA, 2200 South 216th Street, Des Moines, WA 98198; phone: (781) 238-7178; email: *alexei.t.marqueen@faa.gov*.

**SUPPLEMENTARY INFORMATION:****Background**

The FAA was notified by the manufacturer of the detection of iron inclusion in a turbine disk manufactured from the same material used to manufacture certain HPT interstage seals for EA Model GP7270, GP7272, and GP7277 engines. Further investigation by the manufacturer determined that the iron inclusion is attributed to deficiencies in the manufacturing process. The investigation by the manufacturer also determined that certain GP7270, GP7272, and GP7277 HPT interstage seals made from billets manufactured using the same process may have reduced material properties and a lower fatigue life capability due to iron inclusion, which may cause premature fracture and subsequent uncontained failure. This condition, if not addressed, could result in uncontained debris release, damage to the engine, and damage to the airplane. The FAA is issuing this AD to address the unsafe condition on these products.

**FAA's Determination**

The FAA is issuing this AD because the agency has determined the unsafe condition described previously is likely to exist or develop in other products of the same type design.

**AD Requirements**

This AD requires replacement of certain HPT interstage seals with a part eligible for installation.

**Interim Action**

The FAA considers this AD to be an interim action. This unsafe condition is still under investigation by the manufacturer and, depending on the results of that investigation, the FAA may consider further rulemaking action.

**Justification for Immediate Adoption and Determination of the Effective Date**

Section 553(b)(3)(B) of the Administrative Procedure Act (APA) (5 U.S.C. 551 *et seq.*) authorizes agencies to dispense with notice and comment procedures for rules when the agency, for "good cause," finds that those procedures are "impracticable, unnecessary, or contrary to the public interest." Under this section, an agency, upon finding good cause, may issue a final rule without providing notice and seeking comment prior to issuance. Further, section 553(d) of the APA authorizes agencies to make rules effective in less than thirty days, upon a finding of good cause.