



FEDERAL REGISTER

Vol. 90

Thursday,

No. 68

April 10, 2025

Pages 15301–15392

OFFICE OF THE FEDERAL REGISTER



The **FEDERAL REGISTER** (ISSN 0097-6326) is published daily, Monday through Friday, except official holidays, by the Office of the Federal Register, National Archives and Records Administration, under the Federal Register Act (44 U.S.C. Ch. 15) and the regulations of the Administrative Committee of the Federal Register (1 CFR Ch. I). The Superintendent of Documents, U.S. Government Publishing Office, is the exclusive distributor of the official edition. Periodicals postage is paid at Washington, DC.

The **FEDERAL REGISTER** provides a uniform system for making available to the public regulations and legal notices issued by Federal agencies. These include Presidential proclamations and Executive Orders, Federal agency documents having general applicability and legal effect, documents required to be published by act of Congress, and other Federal agency documents of public interest.

Documents are on file for public inspection in the Office of the Federal Register the day before they are published, unless the issuing agency requests earlier filing. For a list of documents currently on file for public inspection, see www.federalregister.gov.

The seal of the National Archives and Records Administration authenticates the **Federal Register** as the official serial publication established under the Federal Register Act. Under 44 U.S.C. 1507, the contents of the **Federal Register** shall be judicially noticed.

The **Federal Register** is published in paper and on 24x microfiche. It is also available online at no charge at www.govinfo.gov, a service of the U.S. Government Publishing Office.

The online edition of the **Federal Register** is issued under the authority of the Administrative Committee of the Federal Register as the official legal equivalent of the paper and microfiche editions (44 U.S.C. 4101 and 1 CFR 5.10). It is updated by 6:00 a.m. each day the **Federal Register** is published and includes both text and graphics from Volume 1, 1 (March 14, 1936) forward. For more information, contact the GPO Customer Contact Center, U.S. Government Publishing Office. Phone 202-512-1800 or 866-512-1800 (toll free). E-mail, gpocusthelp.com.

The annual subscription price for the **Federal Register** paper edition is \$860 plus postage, or \$929, for a combined **Federal Register**, **Federal Register** Index and List of CFR Sections Affected (LSA) subscription; the microfiche edition of the **Federal Register** including the **Federal Register** Index and LSA is \$330, plus postage. Six month subscriptions are available for one-half the annual rate. The prevailing postal rates will be applied to orders according to the delivery method requested. The price of a single copy of the daily **Federal Register**, including postage, is based on the number of pages: \$11 for an issue containing less than 200 pages; \$22 for an issue containing 200 to 400 pages; and \$33 for an issue containing more than 400 pages. Single issues of the microfiche edition may be purchased for \$3 per copy, including postage. Remit check or money order, made payable to the Superintendent of Documents, or charge to your GPO Deposit Account, VISA, MasterCard, American Express, or Discover. Mail to: U.S. Government Publishing Office—New Orders, P.O. Box 979050, St. Louis, MO 63197-9000; or call toll free 1-866-512-1800, DC area 202-512-1800; or go to the U.S. Government Online Bookstore site, see bookstore.gpo.gov.

There are no restrictions on the republication of material appearing in the **Federal Register**.

How To Cite This Publication: Use the volume number and the page number. Example: 90 FR 12345.

Postmaster: Send address changes to the Superintendent of Documents, Federal Register, U.S. Government Publishing Office, Washington, DC 20402, along with the entire mailing label from the last issue received.

SUBSCRIPTIONS AND COPIES

PUBLIC

Subscriptions:

Paper or fiche 202-512-1800
Assistance with public subscriptions 202-512-1806

General online information 202-512-1530; 1-888-293-6498

Single copies/back copies:

Paper or fiche 202-512-1800
Assistance with public single copies 1-866-512-1800
(Toll-Free)

FEDERAL AGENCIES

Subscriptions:

Assistance with Federal agency subscriptions:
Email FRSubscriptions@nara.gov
Phone 202-741-6000

The Federal Register Printing Savings Act of 2017 (Pub. L. 115-120) placed restrictions on distribution of official printed copies of the daily **Federal Register** to members of Congress and Federal offices. Under this Act, the Director of the Government Publishing Office may not provide printed copies of the daily **Federal Register** unless a Member or other Federal office requests a specific issue or a subscription to the print edition. For more information on how to subscribe use the following website link: <https://www.gpo.gov/frsubs>.



Contents

Federal Register

Vol. 90, No. 68

Thursday, April 10, 2025

Civil Rights Cold Case Records Review Board

NOTICES

Formal Determination on Records Release, 15327–15329

Commerce Department

See Foreign-Trade Zones Board

See International Trade Administration

Consumer Product Safety Commission

PROPOSED RULES

Petition Requesting a Mandatory Regulation for Child-Resistant Above-Ground and Portable Pool Ladders, 15324–15326

Energy Department

See Federal Energy Regulatory Commission

Export-Import Bank

NOTICES

Agency Information Collection Activities; Proposals, Submissions, and Approvals:
Application for Approved Finance Provider, 15365
Trade Reference Form, 15365–15366

Federal Aviation Administration

RULES

Airspace Designations and Reporting Points:
Blanding Municipal Airport, Blanding, UT, 15315–15316
Challis, ID; Correction, 15312–15313
Cheyenne Regional/Jerry Olson Field, Cheyenne, WY, 15314–15315
New Bern, NC, 15313–15314
Airworthiness Directives:
Airbus Helicopters, 15301–15304, 15306–15310
Bell Textron Canada Limited Helicopters, 15310–15312
Thommen Aircraft Equipment AG Digital Air Data Computers, 15304–15306

PROPOSED RULES

Airworthiness Directives:
The Boeing Company Airplanes, 15318–15324

Federal Communications Commission

RULES

Television Broadcasting Services:
Monroe, LA, 15316–15317

Federal Election Commission

NOTICES

Designation of Policy-Making Positions, 15366

Federal Energy Regulatory Commission

NOTICES

Combined Filings, 15363–15365
Environmental Assessments; Availability, etc.:
EcoElectrica LP, 15362–15363
Licenses; Exemptions, Applications, Amendments etc.:
Idaho Power Co., 15363

Foreign-Trade Zones Board

NOTICES

Proposed Production Activity:
LMFAKRO, LLC, Foreign-Trade Zone 20, Elizabeth City, NC, 15329–15330

Health and Human Services Department

See National Institutes of Health

International Trade Administration

NOTICES

Antidumping or Countervailing Duty Investigations, Orders, or Reviews:
Certain Freight Rail Couplers and Parts Thereof from the People's Republic of China, 15358–15359
Sales at Less Than Fair Value; Determinations, Investigations, etc.:
Certain Corrosion-Resistant Steel Products from Australia, 15347–15349
Certain Corrosion-Resistant Steel Products from Brazil, 15333–15337
Certain Corrosion-Resistant Steel Products from Canada, 15337–15340
Certain Corrosion-Resistant Steel Products from Mexico, 15349–15352
Certain Corrosion-Resistant Steel Products from South Africa, 15330–15333
Certain Corrosion-Resistant Steel Products from Taiwan, 15359–15362
Certain Corrosion-Resistant Steel Products from the Netherlands, 15352–15355
Certain Corrosion-Resistant Steel Products from the Republic of Turkiye, 15340–15343
Certain Corrosion-Resistant Steel Products from the Socialist Republic of Vietnam, 15343–15346
Certain Corrosion-Resistant Steel Products from the United Arab Emirates, 15355–15358
Subsidy Programs:
Countries Exporting Softwood Lumber and Softwood Lumber Products to the United States, 15333

International Trade Commission

NOTICES

Investigations; Determinations, Modifications, and Rulings, etc.:
Strontium Chromate from Austria and France, 15366

Labor Department

See Labor Statistics Bureau

Labor Statistics Bureau

NOTICES

Agency Information Collection Activities; Proposals, Submissions, and Approvals, 15367–15368

National Highway Traffic Safety Administration

NOTICES

Agency Information Collection Activities; Proposals, Submissions, and Approvals:
Investigation-Based Crash Data Studies, 15384–15388

National Institutes of Health

NOTICES

Hearings, Meetings, Proceedings, etc.:
National Institute of Allergy and Infectious Diseases, 15366

Postal Regulatory Commission**NOTICES**

Hearings, Meetings, Proceedings, etc.:
Section 407 Proceeding, 15368–15369
New Postal Products, 15369–15370

Postal Service**NOTICES**

Privacy Act; Systems of Records, 15370–15373

Presidential Documents**ADMINISTRATIVE ORDERS**

Somalia; Continuation of National Emergency (Notice of April 8, 2025), 15389–15392

Railroad Retirement Board**NOTICES**

Agency Information Collection Activities; Proposals, Submissions, and Approvals, 15373–15375

Securities and Exchange Commission**NOTICES**

Agency Information Collection Activities; Proposals, Submissions, and Approvals, 15376, 15380

Application:

Texas Stock Exchange LLC, 15375–15376
Self-Regulatory Organizations; Proposed Rule Changes:
Cboe EDGX Exchange, Inc., 15379–15380
MIAX Sapphire, LLC, 15376–15379

Small Business Administration**NOTICES**

Surrender of License of Small Business Investment Company:
KLH Capital Fund III, LP, 15380–15381

State Department**NOTICES**

Culturally Significant Objects Imported for Exhibition:
Takashi Murakami: Stepping on the Tail of a Rainbow, 15381
The Many Lives of the Nakagin Capsule Tower, 15381

Susquehanna River Basin Commission**NOTICES**

General Permit, 15383–15384
Grandfathering Registration, 15381
Projects Approved:
Consumptive Uses of Water, 15381–15383

Transportation Department

See Federal Aviation Administration

See National Highway Traffic Safety Administration

Separate Parts In This Issue**Part II**

Presidential Documents, 15389–15392

Reader Aids

Consult the Reader Aids section at the end of this issue for phone numbers, online resources, finding aids, and notice of recently enacted public laws.

To subscribe to the Federal Register Table of Contents electronic mailing list, go to <https://public.govdelivery.com/accounts/USGPOOFR/subscriber/new>, enter your e-mail address, then follow the instructions to join, leave, or manage your subscription.

CFR PARTS AFFECTED IN THIS ISSUE

A cumulative list of the parts affected this month can be found in the Reader Aids section at the end of this issue.

3 CFR

Administrative Orders:

Notice of April 8,
202515391

14 CFR

39 (4 documents)15301,
15304, 15306, 15310

71 (4 documents)15312,
15313, 15314, 15315

Proposed Rules:

39 (2 documents)15318,
15321

16 CFR

Proposed Rules:

Ch. II15324

47 CFR

7315316

Rules and Regulations

Federal Register

Vol. 90, No. 68

Thursday, April 10, 2025

This section of the FEDERAL REGISTER contains regulatory documents having general applicability and legal effect, most of which are keyed to and codified in the Code of Federal Regulations, which is published under 50 titles pursuant to 44 U.S.C. 1510.

The Code of Federal Regulations is sold by the Superintendent of Documents.

DEPARTMENT OF TRANSPORTATION

Federal Aviation Administration

14 CFR Part 39

[Docket No. FAA-2025-0614; Project Identifier MCAI-2025-00008-R; Amendment 39-23010; AD 2025-07-08]

RIN 2120-AA64

Airworthiness Directives; Airbus Helicopters

AGENCY: Federal Aviation Administration (FAA), DOT.

ACTION: Final rule; request for comments.

SUMMARY: The FAA is adopting a new airworthiness directive (AD) for all Airbus Helicopters Model AS332C, AS332C1, AS332L, and AS332L1 helicopters. This AD results from a report of the loss of the tail rotor pitch control due to a fracture of the tail rotor slide of the tail rotor head (TRH) assembly. This AD requires inspecting the slide of the control plate of the TRH assembly for any score, scratch, crack, or corrosion, removing corrosion and replacing the TRH assembly, slide of the control plate, or pitch control assembly if discrepancies are found, and reporting the results of the inspection. This AD prohibits installing an affected TRH assembly unless the actions of this AD are accomplished. All of these actions are specified in a European Union Aviation Safety Agency (EASA) AD, which is incorporated by reference. The FAA is issuing this AD to address the unsafe condition on these products.

DATES: This AD is effective April 25, 2025.

The Director of the Federal Register approved the incorporation by reference of a certain publication listed in this AD as of April 25, 2025.

The FAA must receive comments on this AD by May 27, 2025.

ADDRESSES: You may send comments, using the procedures found in 14 CFR

11.43 and 11.45, by any of the following methods:

- *Federal eRulemaking Portal:* Go to *regulations.gov*. Follow the instructions for submitting comments.

- *Fax:* (202) 493-2251.

- *Mail:* U.S. Department of Transportation, Docket Operations, M-30, West Building Ground Floor, Room W12-140, 1200 New Jersey Avenue SE, Washington, DC 20590.

- *Hand Delivery:* Deliver to Mail address above between 9 a.m. and 5 p.m., Monday through Friday, except Federal holidays.

AD Docket: You may examine the AD docket at *regulations.gov* under Docket No. FAA-2025-0614; or in person at Docket Operations between 9 a.m. and 5 p.m., Monday through Friday, except Federal holidays. The AD docket contains this final rule, the mandatory continuing airworthiness information (MCAI), any comments received, and other information. The street address for Docket Operations is listed above.

Material Incorporated by Reference:

- For EASA material identified in this AD, contact EASA, Konrad-Adenauer-Ufer 3, 50668 Cologne, Germany; phone: +49 221 8999 000; email: ADS@easa.europa.eu; website: easa.europa.eu. You may find the EASA material on the EASA website at ad.easa.europa.eu.

- You may view this material at the FAA, Office of the Regional Counsel, Southwest Region, 10101 Hillwood Pkwy., Room 6N-321, Fort Worth, TX 76177. For information on the availability of this material at the FAA, call (817) 222-5110. It is also available at *regulations.gov* under Docket No. FAA-2025-0614.

FOR FURTHER INFORMATION CONTACT:

Evan Weaver, Aviation Safety Engineer, FAA, 1600 Stewart Avenue, Suite 410, Westbury, NY 11590; phone: (316) 944-8910; email: evan.p.weaver@faa.gov.

SUPPLEMENTARY INFORMATION:

Comments Invited

The FAA invites you to send any written data, views, or arguments about this final rule. Send your comments to an address listed under **ADDRESSES**. Include "Docket No. FAA-2025-0614; Project Identifier MCAI-2025-00008-R" at the beginning of your comments. The most helpful comments reference a specific portion of the final rule, explain the reason for any recommended

change, and include supporting data. The FAA will consider all comments received by the closing date and may amend this final rule because of those comments.

Except for Confidential Business Information (CBI) as described in the following paragraph, and other information as described in 14 CFR 11.35, the FAA will post all comments received, without change, to *regulations.gov*, including any personal information you provide. The agency will also post a report summarizing each substantive verbal contact received about this final rule.

Confidential Business Information

CBI is commercial or financial information that is both customarily and actually treated as private by its owner. Under the Freedom of Information Act (FOIA) (5 U.S.C. 552), CBI is exempt from public disclosure. If your comments responsive to this AD contain commercial or financial information that is customarily treated as private, that you actually treat as private, and that is relevant or responsive to this AD, it is important that you clearly designate the submitted comments as CBI. Please mark each page of your submission containing CBI as "PROPIN." The FAA will treat such marked submissions as confidential under the FOIA, and they will not be placed in the public docket of this AD. Submissions containing CBI should be sent to Evan Weaver, Aviation Safety Engineer, FAA, 1600 Stewart Avenue, Suite 410, Westbury, NY 11590. Any commentary that the FAA receives which is not specifically designated as CBI will be placed in the public docket for this rulemaking.

Background

EASA, which is the Technical Agent for the Member States of the European Union, has issued EASA AD 2025-0001, dated January 6, 2025 (EASA AD 2025-0001) (also referred to as the MCAI), to correct an unsafe condition on Airbus Helicopters Model AS 332 C, AS 332 C1, AS 332 L, AS 332 L1 helicopters. The MCAI states there was a report of the loss of the tail rotor pitch control on an AS 332 L1 helicopter. An investigation discovered a fracture of the tail rotor slide of the TRH assembly. Due to their similarity in type design to the Model AS332L1 helicopters in the affected area, the FAA determined that the unsafe condition could also exist or

develop on Airbus Helicopters Model AS332C, AS332C1, and AS332L helicopters. The unsafe condition, if not addressed, could result in structural failure of the TRH assembly and reduced or loss of control of the helicopter.

You may examine the MCAI in the AD docket at [regulations.gov](https://www.faa.gov/regulations) under Docket No. FAA-2025-0614.

Material Incorporated by Reference Under 1 CFR Part 51

EASA AD 2025-0001 specifies procedures for inspecting the slide of the control plate of the TRH assembly for any score, scratch, crack, or corrosion. Depending on the results of the inspection and the configuration of the helicopter (PRE MOD 0766205 OR POST MOD 0766205), EASA AD 2025-0001 specifies to remove corrosion and replace an affected part (TRH assembly as defined in EASA AD 2025-0001) with one repaired by Airbus Helicopters, replace the slide of the control plate of the TRH pitch assembly, or replace the pitch control assembly. Additionally, if any discrepancy is detected during the inspection, EASA AD 2025-0001 specifies reporting the results of the inspection to Airbus Helicopters. Lastly, EASA AD 2025-001 specifies that it is allowed to install an affected part on a helicopter provided that the affected part passes an inspection.

This material is reasonably available because the interested parties have access to it through their normal course of business or by the means identified in the ADDRESSES section.

FAA's Determination

These products have been approved by EASA and are approved for operation in the United States. Pursuant to the FAA's bilateral agreement with the European Union, EASA has notified the FAA about the unsafe condition described in its AD. The FAA is issuing this AD after evaluating all known relevant information and determining that the unsafe condition described previously is likely to exist or develop on other products of the same type design.

AD Requirements

This AD requires accomplishing the actions specified in EASA AD 2025-0001, described previously, as incorporated by reference, except for any differences identified as exceptions in the regulatory text of this AD.

Interim Action

The FAA considers this AD to be an interim action. The manufacturer is

currently investigating the root cause of the unsafe condition identified in this AD. If final action is later identified, the FAA might consider further rulemaking to address this unsafe condition.

Explanation of Required Compliance Information

In the FAA's ongoing efforts to improve the efficiency of the AD process, the FAA developed a process to use some civil aviation authority (CAA) ADs as the primary source of information for compliance with requirements for corresponding FAA ADs. The FAA has been coordinating this process with manufacturers and CAAs. As a result, EASA AD 2025-0001 will be incorporated by reference in this FAA final rule. This AD therefore, requires compliance with EASA AD 2025-0001 in its entirety through that incorporation, except for any differences identified as exceptions in the regulatory text of this AD. Using common terms that are the same as the heading of a particular section in EASA AD 2025-0001 does not mean that operators need comply only with that section. For example, where the AD requirement refers to "all required actions and compliance times," compliance with this AD requirement is not limited to the section titled "Required Action(s) and Compliance Time(s)" in EASA AD 2025-0001. Material referenced in EASA AD 2025-0001 for compliance is available at [regulations.gov](https://www.faa.gov/regulations) under Docket No. FAA-2025-0614.

Justification for Immediate Adoption and Determination of the Effective Date

Section 553(b) of the Administrative Procedure Act (APA) (5 U.S.C. 551 *et seq.*) authorizes agencies to dispense with notice and comment procedures for rules when the agency, for "good cause," finds that those procedures are "impracticable, unnecessary, or contrary to the public interest." Under this section, an agency, upon finding good cause, may issue a final rule without providing notice and seeking comment prior to issuance. Further, section 553(d) of the APA authorizes agencies to make rules effective in less than thirty days, upon a finding of good cause.

An unsafe condition exists that requires the immediate adoption of this AD without providing an opportunity for public comments prior to adoption. The FAA has found that the risk to the flying public justifies forgoing notice and comment prior to adoption of this rule because the affected components are part of an assembly that is critical to the control of a helicopter. The loss of the tail rotor pitch control has been

reported, and an investigation revealed a fracture of the tail rotor slide. This unsafe condition may lead to a TRH assembly failure, which in turn can cause loss of control of the helicopter. Since this condition can result rapidly and without warning, the required actions must be done within 50 hours TIS, a time period of up to two months based on the average flight-hour utilization rates of these helicopters. However, a significant portion of these helicopters in the U.S. fleet are high usage helicopters, which have an increased likelihood of occurrence of a failure and will reach the compliance time within a period of approximately one week based on the average flight-hour utilization rates of these helicopters. These compliance times are shorter than the time necessary for the public to comment and for publication of the final rule. Accordingly, notice and opportunity for prior public comment are impracticable and contrary to the public interest pursuant to 5 U.S.C. 553(b).

In addition, the FAA finds that good cause exists pursuant to 5 U.S.C. 553(d) for making this amendment effective in less than 30 days, for the same reasons the FAA found good cause to forgo notice and comment.

Regulatory Flexibility Act

The requirements of the Regulatory Flexibility Act (RFA) do not apply when an agency finds good cause pursuant to 5 U.S.C. 553 to adopt a rule without prior notice and comment. Because the FAA has determined that it has good cause to adopt this rule without prior notice and comment, RFA analysis is not required.

Costs of Compliance

The FAA estimates that this AD affects 10 helicopters of U.S. registry. Labor rates are estimated at \$85 per work-hour. Based on these numbers, the FAA estimates that operators may incur the following costs in order to comply with this AD.

Inspecting the TRH assembly will take 2 work-hours for an estimated cost of \$170 per helicopter and \$1,700 for the U.S. fleet.

If required, removing corrosion from the slide of the control plate of the TRH assembly will take 1 work-hour for an estimated cost of \$85 per helicopter.

If required, replacing the slide of the control plate of the TRH assembly will take 6 work-hours and parts will cost \$8,042 for an estimated cost of \$8,552 per slide.

If required, replacing the TRH assembly will take 8 work-hours and

parts will cost \$248,932 for an estimated cost of \$249,612 per TRH assembly.

If required, replacing the pitch control assembly will take 12 work-hours and parts will cost \$30,000 for an estimated cost of \$31,020 per pitch control assembly. If required, reporting the results of the inspection to the manufacturer takes 1 work-hour for an estimated cost of \$85 per helicopter.

Paperwork Reduction Act

A federal agency may not conduct or sponsor, and a person is not required to respond to, nor shall a person be subject to a penalty for failure to comply with a collection of information subject to the requirements of the Paperwork Reduction Act unless that collection of information displays a currently valid OMB Control Number. The OMB Control Number for this information collection is 2120-0056. Public reporting for this collection of information is estimated to take approximately 1 hour per response, including the time for reviewing instructions, searching existing data sources, gathering and maintaining the data needed, and completing and reviewing the collection of information. All responses to this collection of information are mandatory. Send comments regarding this burden estimate or any other aspect of this collection of information, including suggestions for reducing this burden, to: Information Collection Clearance Officer, Federal Aviation Administration, 10101 Hillwood Parkway, Fort Worth, TX 76177-1524.

Authority for This Rulemaking

Title 49 of the United States Code specifies the FAA's authority to issue rules on aviation safety. Subtitle I, section 106, describes the authority of the FAA Administrator. Subtitle VII: Aviation Programs describes in more detail the scope of the Agency's authority.

The FAA is issuing this rulemaking under the authority described in Subtitle VII, Part A, Subpart III, Section 44701: General requirements. Under that section, Congress charges the FAA with promoting safe flight of civil aircraft in air commerce by prescribing regulations for practices, methods, and procedures the Administrator finds necessary for safety in air commerce. This regulation is within the scope of that authority because it addresses an unsafe condition that is likely to exist or develop on products identified in this rulemaking action.

Regulatory Findings

This AD will not have federalism implications under Executive Order 13132. This AD will not have a substantial direct effect on the States, on the relationship between the national government and the States, or on the distribution of power and responsibilities among the various levels of government.

For the reasons discussed above, I certify that this AD:

- (1) Is not a "significant regulatory action" under Executive Order 12866, and
- (2) Will not affect intrastate aviation in Alaska.

List of Subjects in 14 CFR Part 39

Air transportation, Aircraft, Aviation safety, Incorporation by reference, Safety.

The Amendment

Accordingly, under the authority delegated to me by the Administrator, the FAA amends 14 CFR part 39 as follows:

PART 39—AIRWORTHINESS DIRECTIVES

- 1. The authority citation for part 39 continues to read as follows:

Authority: 49 U.S.C. 106(g), 40113, 44701.

§ 39.13 [Amended]

- 2. The FAA amends § 39.13 by adding the following new airworthiness directive:

2025-07-08 Airbus Helicopters:

Amendment 39-23010; Docket No. FAA-2025-0614; Project Identifier MCAI-2025-00008-R.

(a) Effective Date

This airworthiness directive (AD) is effective April 25, 2025.

(b) Affected ADs

None.

(c) Applicability

This AD applies to all Airbus Helicopters Model AS332C, AS332C1, AS332L, and AS332L1 helicopters, certificated in any category.

(d) Subject

Joint Aircraft System Component (JASC) Code 6420 Tail Rotor Head.

(e) Unsafe Condition

This AD was prompted by a report of the loss of the tail rotor pitch control. The FAA is issuing this AD to detect and address any score, scratch, crack, or corrosion on the slide of the control plate of the tail rotor head assembly. The unsafe condition, if not addressed, could result in structural failure of the tail rotor head assembly and reduced or loss of control of the helicopter.

(f) Compliance

Comply with this AD within the compliance times specified, unless already done.

(g) Requirements

Except as specified in paragraph (h) of this AD: Comply with all required actions and compliance times specified in, and in accordance with European Union Aviation Safety Agency (EASA) AD 2025-0001, dated January 6, 2025 (EASA AD 2025-0001).

(h) Exceptions to EASA AD 2025-0001

- (1) Where EASA AD 2025-0001 requires compliance in terms of flight hours, this AD requires using hours time-in-service.
- (2) Where EASA AD 2025-0001 refers to its effective date, this AD requires using the effective date of this AD.
- (3) Where the material referenced in EASA AD 2025-0001 specifies discarding certain parts, this AD requires removing these parts from service.
- (4) Where paragraph (3.1) of EASA AD 2025-0001 specifies replacing the TRH assembly with an assembly repaired in accordance with AH instructions, this AD requires replacement in accordance with a method approved by the Manager, International Validation Branch, FAA, or EASA, or Airbus Helicopters Design Organization Approval (DOA). If approved by the DOA, the approval must include the DOA authorized signature.
- (5) Where the material referenced in EASA AD 2025-0001 specifies sending the TRH to Airbus Helicopters for replacement of the slide, this AD requires replacement in accordance with a method approved by the Manager, International Validation Branch, FAA, or EASA, or Airbus Helicopters DOA. If approved by the DOA, the approval must include the DOA authorized signature.

(6) Where paragraph (4) of EASA AD 2025-0001 states to submit inspection results to AH within 30 days after that inspection, for this AD, report inspection results at the applicable times specified in paragraph (h)(6)(i) or (ii) of this AD.

(i) For an inspection done on or after the effective date of this AD: Submit the report within 7 days after the inspection.

(ii) For an inspection done before the effective date of this AD: Submit the report within 7 days after the effective date of this AD.

(7) This AD does not adopt the "Remarks" section of EASA AD 2025-0001.

(i) Special Flight Permits

Special flight permits are prohibited.

Alternative Methods of Compliance (AMOCs)

(1) The Manager, International Validation Branch, FAA, has the authority to approve AMOCs for this AD, if requested using the procedures found in 14 CFR 39.19. In accordance with 14 CFR 39.19, send your request to your principal inspector or local Flight Standards District Office, as appropriate. If sending information directly to the manager of the International Validation Branch, send it to the attention of the person identified in paragraph (j) of this AD and email to: AMOC@faa.gov.

(2) Before using any approved AMOC, notify your appropriate principal inspector, or lacking a principal inspector, the manager of the local Flight Standards District Office/certificate holding district office.

(j) Additional Information

For more information about this AD, contact Evan Weaver, Aviation Safety Engineer, FAA, 1600 Stewart Avenue, Suite 410, Westbury, NY 11590; phone: (817) 222-5134; email: evan.weaver@faa.gov.

(k) Material Incorporated by Reference

(1) The Director of the Federal Register approved the incorporation by reference of the material listed in this paragraph under 5 U.S.C. 552(a) and 1 CFR part 51.

(2) You must use this material as applicable to do the actions required by this AD, unless the AD specifies otherwise.

(i) European Union Aviation Safety Agency (EASA) AD 2025-0001, dated January 6, 2025.

(ii) [Reserved]

(3) For EASA material identified in this AD, contact EASA, Konrad-Adenauer-Ufer 3, 50668 Cologne, Germany; phone: +49 221 8999 000; email: ADs@easa.europa.eu; website: easa.europa.eu. You may find the EASA material on the EASA website at ad.easa.europa.eu.

(4) You may view this material at the FAA, Office of the Regional Counsel, Southwest Region, 10101 Hillwood Pkwy., Room 6N-321, Fort Worth, TX 76177. For information on the availability of this material at the FAA, call (817) 222-5110.

(5) You may view this material at the National Archives and Records Administration (NARA). For information on the availability of this material at NARA, visit www.archives.gov/federal-register/cfr/ibr-locations or email fr.inspection@nara.gov.

Issued on April 4, 2025.

Paul R. Bernado,

Acting Director, Compliance & Airworthiness Division, Aircraft Certification Service.

[FR Doc. 2025-06120 Filed 4-7-25; 11:15 am]

BILLING CODE 4910-13-P

DEPARTMENT OF TRANSPORTATION

Federal Aviation Administration

14 CFR Part 39

[Docket No. FAA-2024-2322; Project Identifier MCAI-2024-00065-Q; Amendment 39-23002; AD 2025-07-01]

RIN 2120-AA64

Airworthiness Directives; Thommen Aircraft Equipment AG Digital Air Data Computers

AGENCY: Federal Aviation Administration (FAA), DOT.

ACTION: Final rule.

SUMMARY: The FAA is adopting a new airworthiness directive (AD) for certain THOMMEN AIRCRAFT EQUIPMENT

AG (THOMMEN) AC32 Digital Air Data Computers. This AD results from occurrences of AC32 Digital Air Data Computers (ADCs) that stop functioning below certain temperatures. This AD requires replacing an affected AC32 Digital ADC with a serviceable part. The FAA is issuing this AD to address the unsafe condition on these products.

DATES: This AD is effective May 15, 2025.

The Director of the Federal Register approved the incorporation by reference of a certain publication listed in this AD as of May 15, 2025.

ADDRESSES:

AD Docket: You may examine the AD docket at regulations.gov under Docket No. FAA-2024-2322; or in person at Docket Operations between 9 a.m. and 5 p.m., Monday through Friday, except Federal holidays. The AD docket contains this final rule, the mandatory continuing airworthiness information (MCAI), any comments received, and other information. The address for Docket Operations is U.S. Department of Transportation, Docket Operations, M-30, West Building Ground Floor, Room W12-140, 1200 New Jersey Avenue SE, Washington, DC 20590.

Material Incorporated by Reference:

- For THOMMEN AIRCRAFT EQUIPMENT material identified in this AD, contact THOMMEN AIRCRAFT EQUIPMENT AG, Hofackerstrasse 48, 4132 Muttenz, Switzerland; phone: +41 (0) 61 965 22 22; email: sales@thommen.aero; website: thommen.aero.

- You may view this material at the FAA, Airworthiness Products Section, Operational Safety Branch, 901 Locust, Kansas City, MO 64106. For information on the availability of this material at the FAA, call (817) 222-5110. It is also available at regulations.gov under Docket No. FAA-2024-2322.

FOR FURTHER INFORMATION CONTACT:

William Reisenauer, Aviation Safety Engineer, FAA, 1600 Stewart Avenue, Suite 410, Westbury, NY 11590; phone: (516) 228-7301; email: 9-AVS-AIR-BACO-COS@faa.gov.

SUPPLEMENTARY INFORMATION:

Background

The FAA issued a notice of proposed rulemaking (NPRM) to amend 14 CFR part 39 by adding an AD that would apply to certain THOMMEN AC32 Digital Air Data Computers. The NPRM published in the *Federal Register* on September 30, 2024 (89 FR 79480). The NPRM was prompted by AD 2024-0024, dated January 24, 2024, issued by the European Union Aviation Safety Agency (EASA), which is the Technical Agent for the Member States of the European

Union (EASA AD 2024-0024) (also referred to as the MCAI). The MCAI states that there have been occurrences of certain AC32 Digital ADCs that stopped functioning at temperatures below -20 degrees Celsius. The error is detectable and there is no transmission of erroneous data. The problem is caused by the power module and the affected units have been identified. This condition, if not addressed, could result in insufficient navigational data provided to the flight crew, resulting in reduced control of the aircraft. The MCAI requires removing from service each affected part and specifies that only serviceable parts as defined in the MCAI may be installed.

In the NPRM, the FAA proposed to require replacing an affected AC32 Digital ADC with a serviceable part. The FAA is issuing this AD to address the unsafe condition on these products.

You may examine the MCAI in the AD docket at regulations.gov under Docket No. FAA-2024-2322.

Discussion of Final Airworthiness Directive

Comments

The FAA received one comment from an individual commenter and one comment from Bristow VTOL dba Era Helicopters. The following presents the comments received on the NPRM and the FAA's response to each comment.

Request To Revise the Applicability To Include Additional Helicopter Models

An individual commenter stated that Columbia Helicopters, Inc. Model 107-II helicopters and Kawasaki Model 107-II helicopters also have configurations with the subject ADC installed. The FAA infers that the commenter requested that the applicability of the proposed AD be revised to include these additional helicopter models.

Bristow VTOL dba Era Helicopters acknowledged that the proposed AD in paragraph "(c)(2) Applicability" mentions that "Table 1 to paragraph (c)(2)" does not limit the models identified in "Table 1 to paragraph (c)(2)" as being the only models that could have an affected serial number and affected part installed. However, the commenter stated that, while four Model AW189 helicopters are operating in the United States, only one helicopter serial number was identified as having an affected AC32 Digital ADC serial number and part number. The commenter confirmed that affected AC32 Digital ADC serial numbers and part numbers are not installed on any Model AW139 helicopter operating in the United States. Due to this

information, the commenter requested that the FAA include Model AW189 helicopters in “Table 1 to paragraph (c)(2).”

Although, as stated in paragraph (c)(2) of the Applicability section of this AD, the aircraft models specified in Table 1 are not an exhaustive list of affected models, the FAA agrees with the commenters’ requests. The FAA revised “Table 1 to paragraph (c)(2)” of this AD to include Columbia Helicopters, Inc. Model 107–II helicopters, Kawasaki Heavy Industries, Limited Model KV107–II helicopters, and Leonardo S.p.a. Model AW189 helicopters.

Conclusion

These products have been approved by the aviation authority of another country and are approved for operation in the United States. Pursuant to the FAA’s bilateral agreement with this State of Design Authority, it has notified the FAA of the unsafe condition

described in the MCAI referenced above. The FAA reviewed the relevant data, considered the comments received, and determined that air safety requires adopting this AD as proposed. Accordingly, the FAA is issuing this AD to address the unsafe condition on these products. Except for any changes described previously, this AD is adopted as proposed in the NPRM. None of the changes increase the economic burden on any operator.

Material Incorporated by Reference Under 1 CFR Part 51

The FAA reviewed THOMMEN AIRCRAFT EQUIPMENT Service Bulletin SB AC32/07, Revision 1.0, dated August 31, 2023 (THOMMEN SB AC32/07, Revision 1.0). This material specifies procedures for determining if an aircraft is equipped with an affected AC32 Digital ADC listed in Appendix A, determining if the actions specified in THOMMEN SB AC32/07, Revision 1.0,

were already accomplished, and replacing any affected THOMMEN AC32 Digital ADC.

This material is reasonably available because the interested parties have access to it through their normal course of business or by the means identified in the ADDRESSES section.

Costs of Compliance

The FAA estimates that this AD affects 401 AC32 Digital ADCs that are installed on aircraft worldwide. The FAA has no way of determining how many of these ADCs are installed on aircraft of U.S. registry.

The FAA estimates the following costs to comply with this AD. These costs assume all 401 AC32 Digital ADCs are installed on aircraft of U.S. registry. The FAA expects a portion of the affected population to exist outside of the U.S. and the estimated costs to be lower.

ESTIMATED COSTS

Action	Labor cost	Parts cost	Cost per product	Cost on U.S. operators
Replace affected AC32 Digital ADC	12 work-hours × \$85 per hour = \$1,020	\$4,477	\$5,497	\$2,204,297

The FAA has included all known costs in its cost estimate. According to the manufacturer, however, some of the costs of this AD may be covered under warranty, thereby reducing the cost impact on affected operators.

Authority for This Rulemaking

Title 49 of the United States Code specifies the FAA’s authority to issue rules on aviation safety. Subtitle I, section 106, describes the authority of the FAA Administrator. Subtitle VII: Aviation Programs, describes in more detail the scope of the Agency’s authority.

The FAA is issuing this rulemaking under the authority described in Subtitle VII, Part A, Subpart III, Section 44701: General requirements. Under that section, Congress charges the FAA with promoting safe flight of civil aircraft in air commerce by prescribing regulations for practices, methods, and procedures the Administrator finds necessary for safety in air commerce. This regulation is within the scope of that authority because it addresses an unsafe condition that is likely to exist or develop on products identified in this rulemaking action.

Regulatory Findings

This AD will not have federalism implications under Executive Order 13132. This AD will not have a substantial direct effect on the States, on the relationship between the national government and the States, or on the distribution of power and responsibilities among the various levels of government.

For the reasons discussed above, I certify that this AD:

- (1) Is not a “significant regulatory action” under Executive Order 12866,
- (2) Will not affect intrastate aviation in Alaska, and
- (3) Will not have a significant economic impact, positive or negative, on a substantial number of small entities under the criteria of the Regulatory Flexibility Act.

List of Subjects in 14 CFR Part 39

Air transportation, Aircraft, Aviation safety, Incorporation by reference, Safety.

The Amendment

Accordingly, under the authority delegated to me by the Administrator, the FAA amends 14 CFR part 39 as follows:

PART 39—AIRWORTHINESS DIRECTIVES

- 1. The authority citation for part 39 continues to read as follows:

Authority: 49 U.S.C. 106(g), 40113, 44701.

§ 39.13 [Amended]

- 2. The FAA amends § 39.13 by adding the following new airworthiness directive:

2025–07–01 Thommen Aircraft Equipment

AG: Amendment 39–23002; Docket No. FAA–2024–2322; Project Identifier MCAI–2024–00065–Q.

(a) Effective Date

This airworthiness directive (AD) is effective May 15, 2025.

(b) Affected ADs

None.

(c) Applicability

(1) This AD applies to THOMMEN AIRCRAFT EQUIPMENT AG (THOMMEN) AC32 Digital Air Data Computers (ADCs) having an affected part as defined in paragraph (f)(1) of this AD.

(2) This appliance is installed on, but not limited to, the following aircraft models specified in table 1 to paragraph (c)(2) of this AD, certificated in any category.

TABLE 1 TO PARAGRAPH (c)(2)—APPLICABLE AIRCRAFT MODELS

Type certificate holder	Aircraft model
Airbus Defense and Space S.A. (type certificate previously held by Construcciones Aeronauticas, S.A.).	CN-235, CN-235-100, CN-235-200, and CN-235-300.
Airbus Helicopters	AS332C, AS332C1, AS332L, AS332L1, AS332L2.
Airbus Helicopters Deutschland GmbH (AHD)	EC635T2+.
Bell Textron Inc	212, 412, and 412EP.
Bombardier Inc	CL-600-1A11 (600).
Columbia Helicopters Inc	107-II, 234.
General Atomics Aerotek Systems GmbH (type certificate formerly held by DORNIER LUFTFAHRT Inc.).	228-105, 228-101, 228-200, 228-201, 228-202, and 228-212.
Gulfstream Aerospace LP	Westwind Astra 1124 (serial numbers 004-0410).
International Air Response	C-130A.
Kawasaki Heavy Industries, Limited	KV107-II.
Leonardo S.p.a	A109, A10A, A109A II, A109C, A109K2, A109S, 1099SP, AW139, and AW189.
Textron Aviation Inc	200, 300, 500, 501, 550, and 551.
Viking Air Limited	CL-215-6B11 (CL-215T Variant).

(3) This appliance is approved for installation and could be installed on various aircraft modified by Supplemental Type Certificate (STC) No. SR09595RC or ST01523WI.

(d) Subject

Joint Aircraft System Component (JASC) Code 3417, Air Data Computer.

(e) Unsafe Condition

This AD was prompted by occurrences of AC32 Digital ADCs that stopped functioning due to the power module failing at temperatures below -20 degrees Celsius. The unsafe condition, if not addressed, could result in insufficient navigational data provided to the flight crew, resulting in reduced control of the aircraft.

(f) Definitions

For the purpose of this AD the definitions in paragraphs (f)(1) through (4) of this AD apply:

(1) Affected part: THOMMEN AC32 Digital ADCs, part numbers (P/N) AC32.10.21.10.XX, AC32.10.21.11.XX, AC32.11.21.10.XX, and AC32.11.21.11.XX (where XX represents any alpha/numerical sequence), and having a serial number (S/N) listed in Appendix A of THOMMEN AIRCRAFT EQUIPMENT Service Bulletin SB AC32/07, Revision 1.0, dated August 31, 2023 (THOMMEN SB AC32/07 Revision 1.0).

(2) Serviceable part: Any AC32.(X) Digital ADC that is not an affected part; or an affected part where the power module has been replaced by THOMMEN, in accordance with the instructions of THOMMEN SB AC32/07 Revision 1.0.

(3) Group 1 aircraft: Have an affected part installed.

(4) Group 2 aircraft: Do not have an affected part installed but are eligible for AC32.(X) Digital ADC installation.

(g) Compliance

Comply with this AD within the compliance times specified, unless already done.

(h) Required Actions

For Group 1 aircraft: Within 12 months after the effective date of this AD, remove

each affected part from service and replace it with a serviceable part in accordance with paragraph 3.A. of the Accomplishment Instructions in THOMMEN SB AC32/07 Revision 1.0, except where this material specifies to send the removed affected part to the manufacturer, this AD does not require that action.

(i) Parts Installation Prohibition

For Group 1 and 2 aircraft: As of the effective date of this AD, do not install an affected part on any aircraft.

(j) Special Flight Permits

A one-time special flight permit may be issued in accordance with 14 CFR 21.197 and 21.199 in order to fly to a maintenance base to perform the required action in this AD, provided a flight profile above -15 degrees Celsius (5 degrees Fahrenheit) is maintained.

(k) Alternative Methods of Compliance (AMOCs)

(1) The Manager, International Validation Branch, FAA, has the authority to approve AMOCs for this AD, if requested using the procedures found in 14 CFR 39.19. In accordance with 14 CFR 39.19, send your request to your principal inspector or local Flight Standards District Office, as appropriate. If sending information directly to the International Validation Branch, send it to the attention of the person identified in paragraph (l) of this AD and email to: AMOC@faa.gov. Before using any approved AMOC, notify your appropriate principal inspector, or lacking a principal inspector, the manager of the responsible Flight Standards Office.

(l) Additional Information

For more information about this AD, contact William Reisenauer, Aviation Safety Engineer, FAA, 1600 Stewart Avenue, Suite 410, Westbury, NY 11590; phone: (516) 228-7301; email: 9-AVS-AIR-BACO-COS@faa.gov.

(m) Material Incorporated by Reference

(1) The Director of the Federal Register approved the incorporation by reference of the material listed in this paragraph under 5 U.S.C. 552(a) and 1 CFR part 51.

(2) You must use this material as applicable to do the actions required by this AD, unless the AD specifies otherwise.

(i) THOMMEN AIRCRAFT EQUIPMENT Service Bulletin SB AC32/07, Revision 1.0, dated August 31, 2023.

(ii) [Reserved]

(3) For THOMMEN AIRCRAFT EQUIPMENT material in this AD, contact THOMMEN AIRCRAFT EQUIPMENT AG, Hofackerstrasse 48, 4132 Muttentz, Switzerland; phone: +41 (0) 61 965 22 22; email: sales@thommen.aero; website: thommen.aero.

(4) You may view this material at the FAA, Airworthiness Products Section, Operational Safety Branch, 901 Locust, Kansas City, MO 64106. For information on the availability of this material at the FAA, call (817) 222-5110.

(5) You may view this material at the National Archives and Records Administration (NARA). For information on the availability of this material at NARA, visit www.archives.gov/federal-register/cfr/ibr-locations or email fr.inspection@nara.gov.

Issued on March 27, 2025.

Steven W. Thompson,

Acting Deputy Director, Compliance & Airworthiness Division, Aircraft Certification Service.

[FR Doc. 2025-06066 Filed 4-9-25; 8:45 am]

BILLING CODE 4910-13-P

DEPARTMENT OF TRANSPORTATION

Federal Aviation Administration

14 CFR Part 39

[Docket No. FAA-2025-0613; Project Identifier MCAI-2025-00180-R; Amendment 39-23008; AD 2025-07-06]

RIN 2120-AA64

Airworthiness Directives; Airbus Helicopters

AGENCY: Federal Aviation Administration (FAA), DOT.

ACTION: Final rule; request for comments.

SUMMARY: The FAA is superseding Airworthiness Directive (AD) 2024–26–01, which applied to all Airbus Helicopters Model H160–B helicopters. AD 2024–26–01 required measuring the axial play of the rotating scissors spherical bearings, and depending on the results, accomplishing corrective action and reporting inspection results. Since the FAA issued AD 2024–26–01, Airbus Helicopters issued revised material to extend the applicability to all rotating scissors spherical bearing serial numbers, change the initial compliance time, establish repetitive inspections, and extend the reporting requirements. This AD was prompted by a determination that the initial compliance time and reporting requirement needed to be modified and repetitive inspections for certain axial play measurements added. This AD retains the actions required in AD 2024–26–01, revises the initial compliance time, extends the definition of an affected part to all serial numbered rotating scissors spherical bearings, extends the reporting requirements, and requires repetitive inspections. This AD also prohibits installing an affected rotating scissors spherical bearing unless certain requirements are met. These actions are specified in a European Union Aviation Safety Agency (EASA) AD, which is incorporated by reference. The FAA is issuing this AD to address the unsafe condition on these products.

DATES: This AD is effective April 25, 2025.

The Director of the Federal Register approved the incorporation by reference of a certain publication listed in this AD as of April 25, 2025.

The FAA must receive comments on this AD by May 27, 2025.

ADDRESSES: You may send comments, using the procedures found in 14 CFR 11.43 and 11.45, by any of the following methods:

- *Federal eRulemaking Portal:* Go to *regulations.gov*. Follow the instructions for submitting comments.

- *Fax:* (202) 493–2251.

- *Mail:* U.S. Department of Transportation, Docket Operations, M–30, West Building Ground Floor, Room W12–140, 1200 New Jersey Avenue SE, Washington, DC 20590.

- *Hand Delivery:* Deliver to Mail address above between 9 a.m. and 5 p.m., Monday through Friday, except Federal holidays.

AD Docket: You may examine the AD docket at *regulations.gov* under Docket No. FAA–2025–0613; or in person at

Docket Operations between 9 a.m. and 5 p.m., Monday through Friday, except Federal holidays. The AD docket contains this final rule, the mandatory continuing airworthiness information (MCAI), any comments received, and other information. The street address for Docket Operations is listed above.

Material Incorporated by Reference:

- For EASA material identified in this AD, contact EASA, Konrad-Adenauer-Ufer 3, 50668 Cologne, Germany; phone: +49 221 8999 000; email: *ADs@easa.europa.eu*; website: *easa.europa.eu*.

You may find the EASA material on the EASA website at *ad.easa.europa.eu*.

- You may view this material at the FAA, Office of the Regional Counsel, Southwest Region, 10101 Hillwood Parkway, Room 6N–321, Fort Worth, TX 76177. For information on the availability of this material at the FAA, call (817) 222–5110. It is also available at *regulations.gov* under Docket No. FAA–2025–0613.

FOR FURTHER INFORMATION CONTACT: Zain Jamal, Aviation Safety Engineer, FAA, 1600 Stewart Avenue, Suite 410, Westbury, NY 11590; phone: (847) 294–7264; email: *zain.jamal@faa.gov*.

SUPPLEMENTARY INFORMATION:

Comments Invited

The FAA invites you to send any written data, views, or arguments about this final rule. Send your comments to an address listed under the **ADDRESSES** section. Include “Docket No. FAA–2025–0613; Project Identifier MCAI–2025–00180–R” at the beginning of your comments. The most helpful comments reference a specific portion of the final rule, explain the reason for any recommended change, and include supporting data. The FAA will consider all comments received by the closing date and may amend this final rule because of those comments.

Except for Confidential Business Information (CBI) as described in the following paragraph, and other information as described in 14 CFR 11.35, the FAA will post all comments received, without change, to *regulations.gov*, including any personal information you provide. The agency will also post a report summarizing each substantive verbal contact received about this final rule.

Confidential Business Information

CBI is commercial or financial information that is both customarily and actually treated as private by its owner. Under the Freedom of Information Act (FOIA) (5 U.S.C. 552), CBI is exempt from public disclosure. If your

comments responsive to this AD contain commercial or financial information that is customarily treated as private, that you actually treat as private, and that is relevant or responsive to this AD, it is important that you clearly designate the submitted comments as CBI. Please mark each page of your submission containing CBI as “PROPIN.” The FAA will treat such marked submissions as confidential under the FOIA, and they will not be placed in the public docket of this AD. Submissions containing CBI should be sent to Zain Jamal, Aviation Safety Engineer, FAA, 1600 Stewart Avenue, Suite 410, Westbury, NY 11590. Any commentary that the FAA receives which is not specifically designated as CBI will be placed in the public docket for this rulemaking.

Background

The FAA issued AD 2024–26–01, Amendment 39–22915 (90 FR 20, January 2, 2025) (AD 2024–26–01), for all Airbus Helicopters Model H160–B helicopters. AD 2024–26–01 was prompted by MCAI originated by EASA, which is the Technical Agent for the Member States of the European Union Aviation Safety Agency. EASA issued Emergency AD 2024–0206–E, dated October 22, 2024 (EASA AD 2024–0206–E) to correct an unsafe condition identified as excessive axial play of the rotating scissors spherical bearings. AD 2024–26–01 required a one-time measurement of the axial play of the rotating scissors spherical bearings, and depending on the results, accomplishing corrective action and reporting inspection results. The FAA issued AD 2024–26–01 to address excessive axial play of the rotating scissors spherical bearings, which could result in reduced control of the helicopter.

Actions Since AD 2024–26–01 Was Issued

Since the FAA issued AD 2024–26–01, EASA superseded Emergency AD 2024–0206–E, and issued EASA AD 2025–0018, dated January 14, 2025 (EASA AD 2025–0018). EASA AD 2025–0018 states that Airbus Helicopters issued revised material to extend the list of the affected parts to all serial numbers, reduce the initial inspection compliance time, and establish repetitive inspections for certain axial play measurements. The FAA did not issue an AD corresponding to EASA AD 2025–0018. EASA then superseded AD 2025–0018 and issued EASA AD 2025–0040, dated February 14, 2025 (EASA AD 2025–0040) (also referred to as the MCAI), to correct an unsafe condition on Airbus Helicopters Model H160–B helicopters. The MCAI states that

Airbus Helicopters revised its material again to amend the initial inspection compliance time and added reporting requirements when the axial play exceeds 0.20 mm.

You may examine the MCAI in the AD docket at [regulations.gov](https://www.regulations.gov) under Docket No. FAA–2025–0613.

Material Incorporated by Reference Under 1 CFR Part 51

The FAA reviewed EASA AD 2025–0040, which specifies procedures for measuring the axial play of the rotating scissors spherical bearings and replacing the rotating scissors spherical bearings. EASA AD 2025–0040 also specifies reporting inspection results to Airbus Helicopters and prohibits installing an affected rotating scissors spherical bearing unless certain requirements are met.

This material is reasonably available because the interested parties have access to it through their normal course of business or by the means identified in the ADDRESSES section.

FAA’s Determination

These products have been approved by the aviation authority of another country and are approved for operation in the United States. Pursuant to the FAA’s bilateral agreement with this State of Design Authority, it has notified the FAA of the unsafe condition described in the MCAI referenced above. The FAA is issuing this AD after determining that the unsafe condition described previously is likely to exist or develop on other products of the same type design.

AD Requirements

This AD retains certain requirements of AD 2024–26–01. This AD also requires accomplishing the actions specified in the material already described, except for any differences identified as exceptions in the regulatory text of this AD.

Explanation of Required Compliance Information

In the FAA’s ongoing efforts to improve the efficiency of the AD process, the FAA developed a process to use some civil aviation authority (CAA) ADs as the primary source of information for compliance with requirements for corresponding FAA ADs. The FAA has been coordinating this process with manufacturers and CAAs. As a result, EASA AD 2025–0040 is incorporated by reference in this AD. This AD requires compliance with EASA AD 2025–0040 in its entirety through that incorporation, except for any differences identified as exceptions

in the regulatory text of this AD. Using common terms that are the same as the heading of a particular section in EASA AD 2025–0040 does not mean that operators need comply only with that section. For example, where the AD requirement refers to “all required actions and compliance times,” compliance with this AD requirement is not limited to the section titled “Required Action(s) and Compliance Time(s)” in EASA AD 2025–0040. Material required by EASA AD 2025–0040 for compliance will be available at [regulations.gov](https://www.regulations.gov) under Docket No. FAA–2025–0613 after this AD is published.

Interim Action

The FAA considers that this AD is an interim action. If final action is later identified, the FAA might consider further rulemaking.

Justification for Immediate Adoption and Determination of the Effective Date

Section 553(b) of the Administrative Procedure Act (APA) (5 U.S.C. 551 *et seq.*) authorizes agencies to dispense with notice and comment procedures for rules when the agency, for “good cause,” finds that those procedures are “impracticable, unnecessary, or contrary to the public interest.” Under this section, an agency, upon finding good cause, may issue a final rule without providing notice and seeking comment prior to issuance. Further, section 553(d) of the APA authorizes agencies to make rules effective in less than thirty days, upon a finding of good cause.

An unsafe condition exists that requires the immediate adoption of this AD without providing an opportunity for public comments prior to adoption. The FAA has found that the risk to the flying public justifies forgoing notice and comment prior to adoption of this rule because the affected components are part of an assembly that is critical to the control of a helicopter. The FAA has no information pertaining to the extent of excessive axial play of the rotating scissors spherical bearings that may currently exist in helicopters or how quickly degradation may occur. As the serial numbers of the affected part have been expanded, it is possible an initial inspection has not been performed on a helicopter where the unsafe condition exists. This excessive axial play of the rotating scissors spherical bearings is considered early for these parts. Accordingly, the initial actions required by this AD must be accomplished within a time period as short as 30 days for some helicopters. This compliance time is shorter than the time necessary for the public to comment and for publication of the final rule.

Accordingly, notice and opportunity for prior public comment are impracticable and contrary to the public interest pursuant to 5 U.S.C. 553(b).

In addition, the FAA finds that good cause exists pursuant to 5 U.S.C. 553(d) for making this amendment effective in less than 30 days, for the same reasons the FAA found good cause to forgo notice and comment.

Regulatory Flexibility Act

The requirements of the Regulatory Flexibility Act (RFA) do not apply when an agency finds good cause pursuant to 5 U.S.C. 553 to adopt a rule without prior notice and comment. Because the FAA has determined that it has good cause to adopt this rule without prior notice and comment, RFA analysis is not required.

Costs of Compliance

The FAA estimates that this AD affects nine helicopters of U.S. registry. Labor rates are estimated at \$85 per work-hour. Based on these numbers, the FAA estimates the following costs to comply with this AD.

Measuring the axial play of the two rotating scissors spherical bearings takes 2 work-hours for a cost of \$170 per helicopter and \$1,530 for the U.S. fleet, per inspection cycle. Reporting the results takes 1 work-hour for a cost of \$85 per helicopter and up to \$765 for the U.S. fleet, per reporting instance.

If required, replacing a rotating scissors spherical bearing takes 2 work-hours for a cost of \$170 and parts cost \$1,300, for an estimated cost of \$1,470 per bearing.

Paperwork Reduction Act

A federal agency may not conduct or sponsor, and a person is not required to respond to, nor shall a person be subject to a penalty for failure to comply with a collection of information subject to the requirements of the Paperwork Reduction Act unless that collection of information displays a currently valid OMB Control Number. The OMB Control Number for this information collection is 2120–0056. Public reporting for this collection of information is estimated to take approximately 1 hour per response, including the time for reviewing instructions, searching existing data sources, gathering and maintaining the data needed, and completing and reviewing the collection of information. All responses to this collection of information are mandatory. Send comments regarding this burden estimate or any other aspect of this collection of information, including suggestions for reducing this burden, to:

Information Collection Clearance Officer, Federal Aviation Administration, 10101 Hillwood Parkway, Fort Worth, TX 76177-1524.

Authority for This Rulemaking

Title 49 of the United States Code specifies the FAA's authority to issue rules on aviation safety. Subtitle I, section 106, describes the authority of the FAA Administrator. Subtitle VII, Aviation Programs, describes in more detail the scope of the Agency's authority.

The FAA is issuing this rulemaking under the authority described in Subtitle VII, Part A, Subpart III, Section 44701: General requirements. Under that section, Congress charges the FAA with promoting safe flight of civil aircraft in air commerce by prescribing regulations for practices, methods, and procedures the Administrator finds necessary for safety in air commerce. This regulation is within the scope of that authority because it addresses an unsafe condition that is likely to exist or develop on products identified in this rulemaking action.

Regulatory Findings

This AD will not have federalism implications under Executive Order 13132. This AD will not have a substantial direct effect on the States, on the relationship between the national government and the States, or on the distribution of power and responsibilities among the various levels of government.

For the reasons discussed above, I certify that this AD:

(1) Is not a "significant regulatory action" under Executive Order 12866, and

(2) Will not affect intrastate aviation in Alaska.

List of Subjects in 14 CFR Part 39

Air transportation, Aircraft, Aviation safety, Incorporation by reference, Safety.

The Amendment

Accordingly, under the authority delegated to me by the Administrator, the FAA amends 14 CFR part 39 as follows:

PART 39—AIRWORTHINESS DIRECTIVES

■ 1. The authority citation for part 39 continues to read as follows:

Authority: 49 U.S.C. 106(g), 40113, 44701.

§ 39.13 [Amended]

■ 2. The FAA amends § 39.13 by:

■ a. Removing Airworthiness Directive 2024-26-01, Amendment 39-22915 (90 FR 20, January 2, 2025); and

■ b. Adding the following new airworthiness directive:

2025-07-06 Airbus Helicopters:

Amendment 39-23008; Docket No. FAA-2025-0613; Project Identifier MCAI-2025-00180-R.

(a) Effective Date

This airworthiness directive (AD) is effective April 25, 2025.

(b) Affected ADs

This AD replaces AD 2024-26-01, Amendment 39-22915 (90 FR 20, January 2, 2025) (AD 2024-26-01).

(c) Applicability

This AD applies to Airbus Helicopters Model H160-B helicopters, certificated in any category.

(d) Subject

Joint Aircraft System Component (JASC) Code 6230, Main Rotor Mast/Swashplate.

(e) Unsafe Condition

This AD was prompted by report of excessive axial play of the rotating scissors spherical bearings. The FAA is issuing this AD to address excessive axial play of the rotating scissors spherical bearings. The unsafe condition, if not addressed, could result in reduced control of the helicopter.

(f) Compliance

Comply with this AD within the compliance times specified, unless already done.

(g) Requirements

Except as specified in paragraph (h) of this AD: Comply with all required actions and compliance times specified in, and in accordance with European Union Aviation Safety Agency AD 2025-0040, dated February 14, 2025 (EASA AD 2025-0040).

(h) Exceptions to EASA AD 2025-0040

(1) Where EASA AD 2025-0040 requires compliance in terms of flight hours, this AD requires using hours time-in-service.

(2) Where EASA AD 2025-0040 refers to its effective date, this AD requires using the effective date of this AD.

(3) Where EASA AD 2025-0040 refers to January 21, 2025 (the effective date of EASA AD 2025-0018, dated January 14, 2025), this AD requires using the effective date of this AD.

(4) Where Table 3 in appendix 1 of EASA AD 2025-0040 refers to October 24, 2024 (the effective date of EASA AD 2024-0206-E, dated October 22, 2024), this AD requires using January 17, 2025 (the effective date of AD 2024-26-01).

(5) Where paragraph (7) of EASA AD 2025-0040 specifies to report inspection results to AH [Airbus Helicopters] within certain compliance times, for this AD, report inspection results at the applicable times specified in paragraph (h)(5)(i) or (ii) of this AD.

(i) For an inspection done on or after the effective date of this AD: Submit the report within 7 days after the inspection.

(ii) For an inspection done before the effective date of this AD: Submit the report within 7 days after the effective date of this AD.

(6) This AD does not adopt the "Remarks" section of EASA AD 2025-0040.

(i) Special Flight Permits

Special flight permits are prohibited.

(j) Alternative Methods of Compliance (AMOCs)

(1) The Manager, International Validation Branch, FAA, has the authority to approve AMOCs for this AD, if requested using the procedures found in 14 CFR 39.19. In accordance with 14 CFR 39.19, send your request to your principal inspector or local Flight Standards District Office, as appropriate. If sending information directly to the manager of the International Validation Branch, send it to the attention of the person identified in paragraph (k) of this AD and email to: AMOC@faa.gov.

(2) Before using any approved AMOC, notify your appropriate principal inspector, or lacking a principal inspector, the manager of the local flight standards district office/certificate holding district office.

(k) Additional Information

For more information about this AD, contact Zain Jamal, Aviation Safety Engineer, FAA, 1600 Stewart Avenue, Suite 410, Westbury, NY 11590; phone: (847) 294-7264; email: zain.jamal@faa.gov.

(l) Material Incorporated by Reference

(1) The Director of the Federal Register approved the incorporation by reference of the material listed in this paragraph under 5 U.S.C. 552(a) and 1 CFR part 51.

(2) You must use this material as applicable to do the actions required by this AD, unless the AD specifies otherwise.

(i) European Union Aviation Safety Agency (EASA) AD 2025-0040, dated February 14, 2025.

(ii) [Reserved]

(3) For EASA material identified in this AD, contact EASA, Konrad-Adenauer-Ufer 3, 50668 Cologne, Germany; phone: +49 221 8999 000; email: ADS@easa.europa.eu; website: easa.europa.eu. You may find the EASA material on the EASA website at ad.easa.europa.eu.

(4) You may view this material at the FAA, Office of the Regional Counsel, Southwest Region, 10101 Hillwood Parkway, Room 6N-321, Fort Worth, TX 76177. For information on the availability of this material at the FAA, call (817) 222-5110.

(5) You may view this material at the National Archives and Records Administration (NARA). For information on the availability of this material at NARA, visit www.archives.gov/federal-register/cfr/ibr-locations or email fr.inspection@nara.gov.

Issued on March 31, 2025.

Paul R. Bernado,

Acting Director, Compliance & Airworthiness Division, Aircraft Certification Service.

[FR Doc. 2025-06067 Filed 4-9-25; 8:45 am]

BILLING CODE 4910-13-P

DEPARTMENT OF TRANSPORTATION

Federal Aviation Administration

14 CFR Part 39

[Docket No. FAA-2025-0486; Project Identifier MCAI-2025-00348-R; Amendment 39-23007; AD 2025-06-51]

RIN 2120-AA64

Airworthiness Directives; Bell Textron Canada Limited Helicopters

AGENCY: Federal Aviation Administration (FAA), DOT.

ACTION: Final rule; request for comments.

SUMMARY: The FAA is adopting a new airworthiness directive (AD) for certain Bell Textron Canada Limited (Bell) Model 505 helicopters. The FAA previously sent this AD as an emergency AD to all known U.S. owners and operators of these helicopters. This AD was prompted by deformation and/or improper pin engagement in the knuckles of the door hinge on the aft movable ballast box assembly. This AD requires removing all ballast weights from the aft movable ballast box assembly and prohibits the use of ballast weights within the aft movable ballast box assembly, as specified in a Transport Canada emergency AD, which is incorporated by reference. The FAA is issuing this AD to address the unsafe condition on these products.

DATES: This AD is effective April 25, 2025. Emergency AD 2025-06-51, issued on March 21, 2025, which contained the requirements of this amendment, was effective with actual notice.

The Director of the Federal Register approved the incorporation by reference of a certain publication listed in this AD as of April 25, 2025.

The FAA must receive comments on this AD by May 27, 2025.

ADDRESSES: You may send comments, using the procedures found in 14 CFR 11.43 and 11.45, by any of the following methods:

- *Federal eRulemaking Portal:* Go to *regulations.gov*. Follow the instructions for submitting comments.
- *Fax:* (202) 493-2251.
- *Mail:* U.S. Department of Transportation, Docket Operations, M-

30, West Building Ground Floor, Room W12-140, 1200 New Jersey Avenue SE, Washington, DC 20590.

• *Hand Delivery:* Deliver to Mail address above between 9 a.m. and 5 p.m., Monday through Friday, except Federal holidays.

AD Docket: You may examine the AD docket at *regulations.gov* under Docket No. FAA-2025-0486; or in person at Docket Operations between 9 a.m. and 5 p.m., Monday through Friday, except Federal holidays. The AD docket contains this final rule, the mandatory continuing airworthiness information (MCAI), any comments received, and other information. The street address for Docket Operations is listed above.

Material Incorporated by Reference:

• For Transport Canada material identified in this AD, contact Transport Canada, Transport Canada National Aircraft Certification, 159 Cleopatra Drive, Nepean, Ontario K1A 0N5, Canada; phone: (888) 663-3639; email: *TC.AirworthinessDirectives-Consignesdenavigabilite.TC@tc.gc.ca*. You may view this material on the Transport Canada website at *tc.canada.ca/en/aviation*.

• You may view this material at the FAA, Office of the Regional Counsel, Southwest Region, 10101 Hillwood Parkway, Room 6N-321, Fort Worth, TX 76177. For information on the availability of this material at the FAA, call (817) 222-5110. It is also available at *regulations.gov* under Docket No. FAA-2025-0486.

FOR FURTHER INFORMATION CONTACT: Dan McCully, Aviation Safety Engineer, FAA, 1600 Stewart Avenue, Suite 410, Westbury, NY 11590; phone: (404) 474-5548; email: *William.McCully@faa.gov*.

SUPPLEMENTARY INFORMATION:

Comments Invited

The FAA invites you to send any written data, views, or arguments about this final rule. Send your comments to an address listed under the **ADDRESSES** section. Include “Docket No. FAA-2025-0486; Project Identifier MCAI-2025-00348-R” at the beginning of your comments. The most helpful comments reference a specific portion of the final rule, explain the reason for any recommended change, and include supporting data. The FAA will consider all comments received by the closing date and may amend this final rule because of those comments.

Except for Confidential Business Information (CBI) as described in the following paragraph, and other information as described in 14 CFR 11.35, the FAA will post all comments received, without change, to

regulations.gov, including any personal information you provide. The agency will also post a report summarizing each substantive verbal contact received about this final rule.

Confidential Business Information

CBI is commercial or financial information that is both customarily and actually treated as private by its owner. Under the Freedom of Information Act (FOIA) (5 U.S.C. 552), CBI is exempt from public disclosure. If your comments responsive to this AD contain commercial or financial information that is customarily treated as private, that you actually treat as private, and that is relevant or responsive to this AD, it is important that you clearly designate the submitted comments as CBI. Please mark each page of your submission containing CBI as “PROPIN.” The FAA will treat such marked submissions as confidential under the FOIA, and they will not be placed in the public docket of this AD. Submissions containing CBI should be sent to Dan McCully, Aviation Safety Engineer, FAA, 1600 Stewart Avenue, Suite 410, Westbury, NY 11590. Any commentary that the FAA receives that is not specifically designated as CBI will be placed in the public docket for this rulemaking.

Background

The FAA issued Emergency AD 2025-06-51, dated March 21, 2025 (the emergency AD), to address an unsafe condition on Bell Model 505 helicopters, serial numbers 65011 and subsequent with ballast kit part number (P/N) SLS-706-201-007 installed. The FAA sent the emergency AD to all known U.S. owners and operators of these helicopters. The emergency AD requires removing all ballast weights from the aft movable ballast box assembly, P/N SLS-706-201-007, and prohibits the use of ballast weights within the aft movable ballast box assembly.

The emergency AD was prompted by Emergency AD CF-2025-17, dated March 19, 2025 (Transport Canada Emergency AD CF-2025-17) (also referred to as “the MCAI”), issued by Transport Canada, which is the aviation authority for Canada. The MCAI states that Bell has discovered possible plastic deformation and/or improper pin engagement in the knuckles of the door hinge on the aft movable ballast box assembly, P/N SLS-706-201-007. Ballast weights escaping the ballast box have a high potential of striking the tail rotor assembly. The FAA is issuing this AD to prevent damage to and departure of tail rotor blades, loss of tail rotor thrust, and severe vibrations. Any of

these conditions, if not addressed, will lead to loss of control of the helicopter.

You may examine the MCAI in the AD docket at *regulations.gov* under Docket No. FAA–2025–0486.

Material Incorporated by Reference Under 1 CFR Part 51

The FAA reviewed Transport Canada Emergency AD CF–2025–17, which specifies procedures for removing all ballast weights from the aft movable ballast box assembly, P/N SLS–706–201–007, and prohibits the use of ballast weights within the aft movable ballast box assembly.

This material is reasonably available because the interested parties have access to it through their normal course of business or by the means identified in the ADDRESSES section.

FAA’s Determination

This product has been approved by the aviation authority of another country and is approved for operation in the United States. Pursuant to the FAA’s bilateral agreement with this State of Design Authority, it has notified the FAA of the unsafe condition described in the MCAI described above. The FAA is issuing this AD after determining that the unsafe condition described previously is likely to exist or develop on other products of the same type design.

AD Requirements

This AD requires accomplishing the actions specified in the MCAI, except for any differences identified as

exceptions in the regulatory text of this AD.

Interim Action

The FAA considers that this AD is an interim action. Bell is developing inspection procedures intended to address the unsafe conditions. Once this inspection is developed, approved, and available, the FAA might consider additional rulemaking.

Justification for Immediate Adoption and Determination of the Effective Date

Section 553(b) of the Administrative Procedure Act (APA) (5 U.S.C. 551 *et seq.*) authorizes agencies to dispense with notice and comment procedures for rules when the agency, for “good cause,” finds that those procedures are “impracticable, unnecessary, or contrary to the public interest.” Under this section, an agency, upon finding good cause, may issue a final rule without providing notice and seeking comment prior to issuance. Further, section 553(d) of the APA authorizes agencies to make rules effective in less than thirty days, upon a finding of good cause.

An unsafe condition exists that required the immediate adoption of Emergency AD 2025–06–51 issued on March 21, 2025, to all known U.S. owners and operators of these helicopters. The FAA found that the risk to the flying public justified waiving notice and comment prior to adoption of this rule because ballast weights escaping the ballast box have a high potential of striking the tail rotor

assembly, which could result in damage and/or departure of tail rotor blades, loss of tail rotor thrust, and severe vibrations; these conditions will result in loss of control of the helicopter. In addition, this AD requires removal of the ballast weights from the aft movable ballast box assembly before further flight. These conditions still exist, therefore, notice and opportunity for prior public comment are impracticable and contrary to the public interest pursuant to 5 U.S.C. 553(b).

In addition, the FAA finds that good cause exists pursuant to 5 U.S.C. 553(d) for making this amendment effective in less than 30 days, for the same reasons the FAA found good cause to forgo notice and comment.

Regulatory Flexibility Act

The requirements of the Regulatory Flexibility Act (RFA) do not apply when an agency finds good cause pursuant to 5 U.S.C. 553 to adopt a rule without prior notice and comment. Because the FAA has determined that it has good cause to adopt this rule without notice and comment, RFA analysis is not required.

Costs of Compliance

The FAA estimates that this AD affects 174 helicopters of U.S. registry. The FAA estimates the following costs to comply with this AD:

ESTIMATED COSTS OF REQUIRED ACTIONS

Action	Labor cost	Parts cost	Cost per product	Cost on U.S. operators
Inspection, weight removal	0.5 work-hour × \$85 per hour = \$42.50	\$0	\$42.50	\$7,395

Authority for This Rulemaking

Title 49 of the United States Code specifies the FAA’s authority to issue rules on aviation safety. Subtitle I, section 106, describes the authority of the FAA Administrator. Subtitle VII: Aviation Programs describes in more detail the scope of the Agency’s authority.

The FAA is issuing this rulemaking under the authority described in Subtitle VII, Part A, Subpart III, Section 44701: General requirements. Under that section, Congress charges the FAA with promoting safe flight of civil aircraft in air commerce by prescribing regulations for practices, methods, and procedures the Administrator finds necessary for safety in air commerce.

This regulation is within the scope of that authority because it addresses an unsafe condition that is likely to exist or develop on products identified in this rulemaking action.

Regulatory Findings

This AD will not have federalism implications under Executive Order 13132. This AD will not have a substantial direct effect on the States, on the relationship between the national government and the States, or on the distribution of power and responsibilities among the various levels of government.

For the reasons discussed above, I certify that this AD:

(1) Is not a “significant regulatory action” under Executive Order 12866, and

(2) Will not affect intrastate aviation in Alaska.

List of Subjects in 14 CFR Part 39

Air transportation, Aircraft, Aviation safety, Incorporation by reference, Safety.

The Amendment

Accordingly, under the authority delegated to me by the Administrator, the FAA amends 14 CFR part 39 as follows:

PART 39—AIRWORTHINESS DIRECTIVES

■ 1. The authority citation for part 39 continues to read as follows:

Authority: 49 U.S.C. 106(g), 40113, 44701.

§ 39.13 [Amended]

■ 2. The FAA amends § 39.13 by adding the following new airworthiness directive:

2025–06–51 Bell Textron Canada Limited: Amendment 39–23007; Docket No. FAA–2025–0486; Project Identifier MCAI–2025–00348–R.

(a) Effective Date

The FAA issued emergency Airworthiness Directive (AD) 2025–06–51 on March 21, 2025, directly to affected owners and operators. As a result of such actual notice, the emergency AD was effective for those owners and operators on the date it was provided. This AD contains the same requirements as the emergency AD and, for those who did not receive actual notice, is effective on April 25, 2025.

(b) Affected ADs

None.

(c) Applicability

This AD applies to Bell Textron Canada Limited Model 505 helicopters, certificated in any category, as identified in Transport Canada Emergency AD CF–2025–17, dated March 19, 2025 (Transport Canada Emergency AD CF–2025–17).

(d) Subject

Joint Aircraft System Component (JASC) Code 2500, Equipment/furnishings.

(e) Unsafe Condition

This AD was prompted by deformation and/or improper pin engagement in the knuckles of the door hinge on the aft movable ballast box assembly, which could allow the ballast weights to escape the ballast box and strike the tail rotor assembly. The FAA is issuing this AD to prevent damage and/or departure of tail rotor blades, loss of tail rotor thrust, and severe vibrations. The unsafe condition, if not addressed, could result in loss of control of the helicopter.

(f) Compliance

Comply with this AD within the compliance times specified, unless already done.

(g) Requirements

Except as specified in paragraph (h) of this AD: Comply with all required actions and compliance times specified in, and in accordance with, Transport Canada Emergency AD CF–2025–17.

(h) Exception to Transport Canada Emergency AD CF–2025–17

Where Transport Canada Emergency AD CF–2025–17 refers to its effective date, this AD requires using the effective date of this AD.

(i) Special Flight Permits

Special flight permits are prohibited.

(j) Additional AD Provisions

The following provisions also apply to this AD:

(1) *Alternative Methods of Compliance (AMOCs):* The Manager, International Validation Branch, FAA, has the authority to approve AMOCs for this AD, if requested using the procedures found in 14 CFR 39.19. In accordance with 14 CFR 39.19, send your request to your principal inspector or responsible Flight Standards Office, as appropriate. If sending information directly to the manager of the International Validation Branch, send it to the attention of the person identified in paragraph (k) of this AD and email to AMOC@faa.gov. Before using any approved AMOC, notify your appropriate principal inspector, or lacking a principal inspector, the manager of the responsible Flight Standards Office.

(2) *Contacting the Manufacturer:* For any requirement in this AD to obtain instructions from a manufacturer, those instructions must be accomplished using a method approved by the Manager, International Validation Branch, FAA; or Transport Canada; or Bell Textron Canada Limited's Transport Canada Design Approval Organization (DAO). If approved by the DAO, the approval must include the DAO-authorized signature.

(k) Additional Information

For more information about this AD, contact Dan McCully, Aviation Safety Engineer, FAA, 1600 Stewart Avenue, Suite 410, Westbury, NY 11590; phone: (404) 474–5548; email: William.McCully@faa.gov.

(l) Material Incorporated by Reference

(1) The Director of the Federal Register approved the incorporation by reference of the material listed in this paragraph under 5 U.S.C. 552(a) and 1 CFR part 51.

(2) You must use this material as applicable to do the actions required by this AD, unless this AD specifies otherwise.

(i) Transport Canada Emergency AD CF–2025–17, dated March 19, 2025.

(ii) [Reserved]

(3) For Transport Canada material identified in this AD, contact Transport Canada, Transport Canada National Aircraft Certification, 159 Cleopatra Drive, Nepean, Ontario K1A 0N5, Canada; phone: (888) 663–3639; email: TC.AirworthinessDirectives-Consignesdenavigabilite.TC@tc.gc.ca. You may view this material on the Transport Canada website at tc.canada.ca/en/aviation.

(4) You may view this material at the FAA, Office of the Regional Counsel, Southwest Region, 10101 Hillwood Parkway, Room 6N–321, Fort Worth, TX 76177. For information on the availability of this material at the FAA, call (817) 222–5110.

(5) You may view this material at the National Archives and Records Administration (NARA). For information on the availability of this material at NARA, visit www.archives.gov/federal-register/cfr/ibr-locations or email fr.inspection@nara.gov.

Issued on March 28, 2025.

Paul R. Bernado,

Acting Director, Compliance & Airworthiness Division, Aircraft Certification Service.

[FR Doc. 2025–06121 Filed 4–7–25; 11:15 am]

BILLING CODE 4910–13–P

DEPARTMENT OF TRANSPORTATION

Federal Aviation Administration

14 CFR Part 71

[Docket No. FAA–2024–2491; Airspace Docket No. 23–ANM–23]

RIN 2120–AA66

Establishment of Class E Airspace; Challis Airport, Challis, ID; Correction

AGENCY: Federal Aviation Administration (FAA), DOT.

ACTION: Final rule; correction.

SUMMARY: The FAA is correcting a typographical error in the agency docket number within the final rule published in the **Federal Register** on March 20, 2025, establishing Class E airspace extending upward from 700 feet above the surface in Challis, ID.

DATES: Effective 0901 UTC, June 12, 2025. The Director of the Federal Register approves this incorporation by reference action under 1 CFR part 51, subject to the annual revision of FAA Order 7400.11, Airspace Designations and Reporting Points, and publication of conforming amendments.

FOR FURTHER INFORMATION CONTACT: Jeffrey Drasin, Federal Aviation Administration, Western Service Center, Operations Support Group, 2200 S 216th Street, Des Moines, WA 98198; telephone (206) 231–2248.

SUPPLEMENTARY INFORMATION:

History

The FAA published a final rule in the **Federal Register** (90 FR 13067; March 20, 2025) establishing Class E airspace at Challis Airport, Challis, ID. Subsequent to publication, the FAA identified an error within the agency docket number, which was also present within the notice of proposed rulemaking. This action corrects the final rule by replacing the incorrect agency docket number (FAA–2023–2491) with the correct one (FAA–2024–2491).

Correction to the Final Rule

On page 13607, in the first column, immediately under “14 CFR Part 71” and within the document headings, the agency docket number is corrected to read “FAA–2024–2491”.

Issued in Des Moines, Washington, on April 2, 2025.

B.G. Chew,

Group Manager, Western Service Center, Operations Support Group.

[FR Doc. 2025-06035 Filed 4-9-25; 8:45 am]

BILLING CODE 4910-13-P

DEPARTMENT OF TRANSPORTATION

Federal Aviation Administration

14 CFR Part 71

[Docket No. FAA-2024-1965; Airspace Docket No. 24-ASO-26]

RIN 2120-AA66

Amendment of Class E Airspace; New Bern, NC

AGENCY: Federal Aviation Administration (FAA), DOT.

ACTION: Final rule.

SUMMARY: This action amends Class E airspace extending upward from 700 feet above the surface for New Bern, NC, by adding airspace for CarolinaEast Medical Center Heliport, New Bern, NC. The controlled airspace is required to support the new RNAV (GPS) standard instrument approach procedures for instrument flight rules (IFR) operations at the heliport. This action also corrects the state abbreviation in the header from AL to NC.

DATES: Effective 0901 UTC, June 12, 2025. The Director of the Federal Register approves this incorporation by reference action under 1 CFR part 51, subject to the annual revision of FAA Order JO 7400.11 and publication of conforming amendments.

ADDRESSES: A copy of the notice of proposed rulemaking (NPRM), all comments received, this final rule, and all background material may be viewed online at www.regulations.gov using the FAA Docket number. Electronic retrieval help and guidelines are available on the website. It is available 24 hours a day, 365 days a year.

FAA Order JO 7400.11J, Airspace Designations, and Reporting Points, as well as subsequent amendments, can be viewed online at www.faa.gov/air_traffic/publications/. For further information, you may also contact the Rules and Regulations Group, Policy Directorate, Federal Aviation Administration, 600 Independence Avenue SW, Washington, DC 20597; telephone: (202) 267-8783.

FOR FURTHER INFORMATION CONTACT: Robert Scott Stuart, Operations Support Group, Eastern Service Center, Federal Aviation Administration, 1701

Columbia Avenue, College Park, GA 30337; telephone: (404) 305-5926.

SUPPLEMENTARY INFORMATION:

Authority for This Rulemaking

The FAA's authority to issue rules regarding aviation safety is found in Title 49 of the United States Code. Subtitle I, Section 106, describes the authority of the FAA Administrator. Subtitle VII, Aviation Programs, describes in more detail the scope of the agency's authority. This rulemaking is promulgated under the authority described in Subtitle VII, Part A, Subpart I, Section 40103. Under that section, the FAA is charged with prescribing regulations to assign the use of airspace necessary to ensure the safety of aircraft and the efficient use of airspace. This regulation is within the scope of that authority, as it amends Class E airspace extending upward from 700 feet above the surface at CarolinaEast Medical Center Heliport, New Bern, NC.

History

The FAA published a notice of proposed rulemaking for Docket No. FAA 2024-1965 in the **Federal Register** (89 FR 87989; November 6, 2024), proposing to amend Class E airspace extending upward from 700 feet above the surface for CarolinaEast Medical Center Heliport, New Bern, NC. Interested parties were invited to participate in this rulemaking effort by submitting written comments on the proposal to the FAA. No comments were received.

Incorporation by Reference

Class E airspace is published in paragraph 6005 of FAA Order JO 7400.11, Airspace Designations and Reporting Points, which is incorporated by reference in 14 CFR 71.1 on an annual basis. This document amends the current version of that order, FAA Order JO 7400.11J, dated July 31, 2024, and effective September 15, 2024. These amendments will be published in the next update to FAA Order JO 7400.11. FAA Order JO 7400.11J is publicly available as listed in the **ADDRESSES** section of this document. FAA Order JO 7400.11J lists Class A, B, C, D, and E airspace areas, air traffic service routes, and reporting points.

The Rule

This amendment to 14 CFR part 71 amends Class E airspace extending upward from 700 feet above the surface within a 6-mile radius of CarolinaEast Medical Center Heliport, New Bern, NC, providing the controlled airspace required to support the new RNAV

(GPS) standard instrument approach procedures for IFR operations at the heliport. This action also corrects the state abbreviation in the title from AL (Alabama) to NC (North Carolina). Controlled airspace is necessary for the safety and management of instrument flight rules (IFR) operations in the area.

Regulatory Notices and Analyses

The FAA has determined that this regulation only involves an established body of technical regulations for which frequent and routine amendments are necessary to keep them operationally current. It, therefore: (1) is not a "significant regulatory action" under Executive Order 12866; (2) is not a "significant rule" under DOT Regulatory Policies and Procedures (44 FR 11034; February 26, 1979); and (3) does not warrant preparation of a Regulatory Evaluation as the anticipated impact is so minimal. Since this is a routine matter that will only affect air traffic procedures and air navigation, it is certified that this proposed rule, when promulgated, will not have a significant economic impact on a substantial number of small entities under the criteria of the Regulatory Flexibility Act.

Environmental Review

The FAA has determined that this action qualifies for categorical exclusion under the National Environmental Policy Act in accordance with FAA Order 1050.1F, "Environmental Impacts: Policies and Procedures," paragraph 5-6.5a. This airspace action is not expected to cause any potentially significant environmental impacts, and no extraordinary circumstances exist that warrant the preparation of an environmental assessment.

Lists of Subjects in 14 CFR Part 71

Airspace, Incorporation by reference, Navigation (air).

The Amendment

In consideration of the foregoing, the Federal Aviation Administration amends 14 CFR part 71 as follows:

PART 71—DESIGNATION OF CLASS A, B, C, D, AND E AIRSPACE AREAS; AIR TRAFFIC SERVICE ROUTES; AND REPORTING POINTS

■ 1. The authority citation for 14 CFR part 71 continues to read as follows:

Authority: 49 U.S.C. 106(f), 106(g), 40103, 40113, 40120; E.O. 10854, 24 FR 9565, 3 CFR, 1959-1963 Comp., p. 389.

§ 71.1 [Amended]

■ 2. The incorporation by reference in 14 CFR 71.1 of Federal Aviation

Administration Order JO 7400.11J, Airspace Designations and Reporting Points, dated July 31, 2024, and effective September 15, 2024, is amended as follows:

Paragraph 6005 Class E Airspace Areas Extending Upward From 700 Feet or More Above the Surface of the Earth.

* * * * *

ASO NC E5 New Bern, NC [Amended]

Coastal Carolina Regional Airport, NC
(Lat. 35°04'22" N, long. 77°02'35" W)
CarolinaEast Medical Center Heliport, NC
(Lat. 35°06'55" N, long. 77°03'51" W)

That airspace extending upward from 700 feet above the surface within a 7-mile radius of Coastal Carolina Regional Airport and a 6-mile radius of CarolinaEast Medical Center Heliport.

* * * * *

Issued in College Park, Georgia, on April 3, 2025.

Patrick Young,

Manager, Airspace & Procedures Team North, Eastern Service Center, Air Traffic Organization.

[FR Doc. 2025-06025 Filed 4-9-25; 8:45 am]

BILLING CODE 4910-13-P

DEPARTMENT OF TRANSPORTATION

Federal Aviation Administration

14 CFR Part 71

[Docket No. FAA-2024-2456; Airspace Docket No. 24-ANM-71]

RIN 2120-AA66

Modification of Class D and Class E Airspace; Cheyenne Regional/Jerry Olson Field, Cheyenne, WY

AGENCY: Federal Aviation Administration (FAA), DOT.

ACTION: Final rule.

SUMMARY: This action modifies the Class E airspace extending upward from 700 feet above the surface and removes the Class E airspace extending upward from 1,200 feet above the surface at Cheyenne Regional/Jerry Olson Field, Cheyenne, WY. These actions support the safety and management of instrument flight rules (IFR) operations at the airport.

DATES: Effective date 0901 UTC, August 7, 2025. The Director of the Federal Register approves this incorporation by reference action under 1 CFR part 51, subject to the annual revision of FAA Order JO 7400.11 and publication of conforming amendments.

ADDRESSES: A copy of the Notice of Proposed Rulemaking (NPRM), all comments received, this final rule, and all background material may be viewed

online at www.regulations.gov using the FAA Docket number. Electronic retrieval help and guidelines are available on the website. It is available 24 hours each day, 365 days each year.

FAA Order JO 7400.11J, Airspace Designations and Reporting Points, and subsequent amendments can be viewed online at www.faa.gov/air_traffic/publications/. You may also contact the Rules and Regulations Group, Policy Directorate, Federal Aviation Administration, 600 Independence Avenue SW, Washington, DC 20597; telephone: (202) 267-8783.

FOR FURTHER INFORMATION CONTACT: Nathan A. Chaffman, Federal Aviation Administration, Western Service Center, Operations Support Group, 2200 S 216th Street, Des Moines, WA 98198; telephone (206) 231-3460.

SUPPLEMENTARY INFORMATION:

Authority for This Rulemaking

The FAA's authority to issue rules regarding aviation safety is found in Title 49 of the United States Code. Subtitle I, Section 106 describes the authority of the FAA Administrator. Subtitle VII, Aviation Programs, describes in more detail the scope of the agency's authority. This rulemaking is promulgated under the authority described in Subtitle VII, Part A, Subpart I, Section 40103. Under that section, the FAA is charged with prescribing regulations to assign the use of the airspace necessary to ensure the safety of aircraft and the efficient use of airspace. This regulation is within the scope of that authority as it modifies Class E airspace to support IFR operations at Cheyenne Regional/Jerry Olson Field, Cheyenne, WY.

History

The FAA published a notice of proposed rulemaking for Docket No. FAA-2024-2456 in the **Federal Register** (89 FR 99173; December 10, 2024), proposing to modify Class D and E airspace at Cheyenne Regional/Jerry Olson Field, WY. Interested parties were invited to participate in this rulemaking effort by submitting written comments on the proposal to the FAA. No comments were received.

Differences From the NPRM

The NPRM proposed administrative modifications to update the airport's legal descriptions for their Class D airspace and Class E airspace designated as a surface area. Both descriptions were proposed to replace the use of the phrase "Notice to Airmen" to "Notice to Air Missions." However, subsequent to the publication of the NPRM and effective February 10, 2025, the FAA's

definition of the acronym "NOTAM" reverted back to "Notice to Airmen." As such, any proposed modifications to the Class D airspace and Class E airspace designated as a surface area within the NPRM were administrative in nature and are no longer necessary.

Incorporation by Reference

Class E5 airspace designations are published in paragraph 6005 of FAA Order JO 7400.11, Airspace Designations and Reporting Points, which is incorporated by reference in 14 CFR 71.1 on an annual basis. This document amends the current version of that order, FAA Order JO 7400.11J, dated July 31, 2024, and effective September 15, 2024. These updates will be published in the next update to FAA Order JO 7400.11.

FAA Order JO 7400.11J lists Class A, B, C, D, and E airspace areas, air traffic service routes, and reporting points.

The Rule

This action amends 14 CFR part 71 by modifying the Class E airspace extending upward from 700 feet above the surface and removing the Class E airspace extending upward from 1,200 feet above the surface at Cheyenne Regional/Jerry Olson Field, Cheyenne, WY.

The westward portion of the Class E airspace extending upward from 700 feet above the surface is widened to be within a 9.1-mile radius of the airport between the airport's 209° bearing clockwise to its 336° bearing due to rising terrain. This additional Class E airspace will better contain diverse IFR departure operations until they reach 1,200 feet above the surface.

The Class E airspace extending upward from 1,200 feet above the surface at the airport is redundant and is removed. The Denver Class E6 en route domestic airspace provides sufficient containment of arriving IFR operations at 1,500 feet and higher above the surface and departing IFR operations from the point they reach 1,200 feet above the surface until reaching overlying or adjacent controlled airspace.

Regulatory Notices and Analyses

The FAA has determined that this regulation only involves an established body of technical regulations for which frequent and routine amendments are necessary to keep them operationally current. It, therefore: (1) is not a "significant regulatory action" under Executive Order 12866; (2) is not a "significant rule" under DOT Regulatory Policies and Procedures (44 FR 11034; February 26, 1979); and (3)

does not warrant preparation of a regulatory evaluation as the anticipated impact is so minimal. Since this is a routine matter that only affects air traffic procedures and air navigation, it is certified that this rule, when promulgated, does not have a significant economic impact on a substantial number of small entities under the criteria of the Regulatory Flexibility Act.

Environmental Review

The FAA has determined that this action qualifies for categorical exclusion under the National Environmental Policy Act in accordance with FAA Order 1050.1F, "Environmental Impacts: Policies and Procedures," paragraph 5–6.5.a. This airspace action is not expected to cause any potentially significant environmental impacts, and no extraordinary circumstances exist that warrant preparation of an environmental assessment.

Lists of Subjects in 14 CFR Part 71

Airspace, Incorporation by reference, Navigation (air).

The Amendment

In consideration of the foregoing, the Federal Aviation Administration amends 14 CFR part 71 as follows:

PART 71—DESIGNATION OF CLASS A, B, C, D, AND E AIRSPACE AREAS; AIR TRAFFIC SERVICE ROUTES; AND REPORTING POINTS

■ 1. The authority citation for 14 CFR part 71 continues to read as follows:

Authority: 49 U.S.C. 106(f), 106(g), 40103, 40113, 40120; E.O. 10854, 24 FR 9565, 3 CFR, 1959–1963 Comp., p.389.

§ 71.1 [Amended]

■ 2. The incorporation by reference in 14 CFR 71.1 of FAA Order JO 7400.11J, Airspace Designations and Reporting Points, dated July 31, 2024, and effective September 15, 2024, is amended as follows:

Paragraph 6005 Class E Airspace Areas Extending Upward From 700 Feet or More Above the Surface of the Earth.

* * * * *

ANM WY E5 Cheyenne, WY [Amended]

Cheyenne Regional/Jerry Olson Field, WY (Lat. 41°09'20" N, long. 104°48'38" W)

That airspace extending upward from 700 feet above the surface within an 8.1-mile radius of Cheyenne Regional/Jerry Olson Field, within a 9.1-mile radius of the airport between its 209° bearing clockwise to its 336° bearing, within 2.4 miles each side of the airport's 028° bearing extending from its 8.1-mile radius to 10.8 miles northeast of the airport, and within 2.2 miles each side of the

airport's 275° bearing extending from its 9.1-mile radius to 10.6 miles west of the airport.

* * * * *

Issued in Des Moines, Washington, on April 1, 2025.

B.G. Chew,

Group Manager, Operations Support Group, Western Service Center.

[FR Doc. 2025–06055 Filed 4–9–25; 8:45 am]

BILLING CODE 4910–13–P

DEPARTMENT OF TRANSPORTATION

Federal Aviation Administration

14 CFR Part 71

[Docket No. FAA–2024–2499; Airspace Docket No. 24–ANM–116]

RIN 2120–AA66

Establishment of Class E Airspace; Blanding Municipal Airport, Blanding, UT

AGENCY: Federal Aviation Administration (FAA), DOT.

ACTION: Final rule.

SUMMARY: This action modifies the Class E airspace at Blanding Municipal Airport, UT by establishing Class E airspace extending upward from 700 feet above the surface and removing Class E airspace extending from 1,200 feet above the surface at the airport. Additionally, this action makes administrative amendments to update the airport's legal description. These actions support the airport's instrument flight rules (IFR) operations by modifying transitional Class E airspace at the airport.

DATES: Effective date 0901 UTC, August 7, 2025, The Director of the Federal Register approves this incorporation by reference action under 1 CFR part 51, subject to the annual revision of FAA Order JO 7400.11 and publication of conforming amendments.

ADDRESSES: A copy of the Notice of Proposed Rulemaking (NPRM), all comments received, this final rule, and all background material may be viewed online at www.regulations.gov using the FAA Docket number. Electronic retrieval help and guidelines are available on the website. It is available 24 hours each day, 365 days each year.

FAA Order JO 7400.11J, Airspace Designations and Reporting Points, and subsequent amendments can be viewed online at www.faa.gov/air_traffic/publications/. You may also contact the Rules and Regulations Group, Policy Directorate, Federal Aviation Administration, 600 Independence

Avenue SW, Washington, DC 20597; telephone: (202) 267–8783.

FOR FURTHER INFORMATION CONTACT:

Nathan A. Chaffman, Federal Aviation Administration, Western Service Center, Operations Support Group, 2200 S 216th Street, Des Moines, WA 98198; telephone (206) 231–3460.

SUPPLEMENTARY INFORMATION:

Authority for This Rulemaking

The FAA's authority to issue rules regarding aviation safety is found in Title 49 of the United States Code. Subtitle I, Section 106 describes the authority of the FAA Administrator. Subtitle VII, Aviation Programs, describes in more detail the scope of the agency's authority. This rulemaking is promulgated under the authority described in Subtitle VII, Part A, Subpart I, Section 40103. Under that section, the FAA is charged with prescribing regulations to assign the use of the airspace necessary to ensure the safety of aircraft and the efficient use of airspace. This regulation is within the scope of that authority as it modifies Class E airspace at Blanding Municipal Airport, Blanding, UT, by establishing Class E airspace extending upward from 700 feet above the surface and removing Class E airspace extending from 1,200 feet above the surface at the airport.

History

The FAA published a notice of proposed rulemaking for Docket No. FAA–2024–2499 in the **Federal Register** (90 FR 1049; January 7, 2025), proposing to establish Class E airspace at Blanding Municipal Airport, Blanding, UT. Interested parties were invited to participate in this rulemaking effort by submitting written comments on the proposal to the FAA. No comments were received.

Differences From the NPRM

The exclusionary language for the proposed Class E airspace within the NPRM contained the phrase "excluding that airspace parallel to the runway 3.1 miles west." That phrase has been modified to read "excluding that airspace beyond 3.1 miles west of and parallel to the runway" for added clarity in the airspace description.

Class E airspace extending upward from at least 700 feet above the surface already exists at the airport, however, the NPRM contained verbiage within its title and body that described the desired airspace action as the "establishment" of Class E airspace. The proposal should have included verbiage that instead described the desired action as the "modification" of Class E airspace.

Incorporation by Reference

Class E airspace areas are published in paragraph 6005 of FAA Order JO 7400.11, Airspace Designations and Reporting Points, which is incorporated by reference in 14 CFR 71.1 on an annual basis. This document amends the current version of that order, FAA Order JO 7400.11J, dated July 31, 2024, and effective September 15, 2024. These amendments will be published in the next update to FAA Order JO 7400.11. FAA Order JO 7400.11J is publicly available as listed in the ADDRESSES section of this document. FAA Order JO 7400.11J lists Class A, B, C, D, and E airspace areas, air traffic service routes, and reporting points.

The Rule

This action amends 14 CFR part 71 by modifying the Class E airspace extending upward from 700 feet or more above the surface at Blanding Municipal Airport, Blanding, UT.

Class E airspace extending upward from 700 feet is established within a 6.2-mile radius of the airport excluding that airspace beyond 3.1 miles west of and parallel to the runway, and is extended 11.9 miles to the northeast to contain departing IFR operations until they reach 1,200 feet above the surface. Class E airspace extending upward from 1,200 feet above the surface is removed due to redundancy, as containment is provided by Denver Class E En Route Domestic Airspace that also extends upward from 1,200 feet above the surface.

Finally, the legal description's geographical coordinates for the airport are updated to match the FAA's database.

Regulatory Notices and Analyses

The FAA has determined that this regulation only involves an established body of technical regulations for which frequent and routine amendments are necessary to keep them operationally current. It, therefore: (1) is not a "significant regulatory action" under Executive Order 12866; (2) is not a "significant rule" under DOT Regulatory Policies and Procedures (44 FR 11034; February 26, 1979); and (3) does not warrant preparation of a regulatory evaluation as the anticipated impact is so minimal. Since this is a routine matter that only affects air traffic procedures and air navigation, it is certified that this rule does not have a significant economic impact on a substantial number of small entities under the criteria of the Regulatory Flexibility Act.

Environmental Review

The FAA has determined that this action qualifies for categorical exclusion under the National Environmental Policy Act in accordance with FAA Order 1050.1F, "Environmental Impacts: Policies and Procedures," paragraph 5-6.5.a. This airspace action is not expected to cause any potentially significant environmental impacts, and no extraordinary circumstances exist that warrant preparation of an environmental assessment.

List of Subjects in 14 CFR Part 71

Airspace, Incorporation by reference, Navigation (air).

The Amendment

In consideration of the foregoing, the Federal Aviation Administration amends 14 CFR part 71 as follows:

PART 71—DESIGNATION OF CLASS A, B, C, D, AND E AIRSPACE AREAS; AIR TRAFFIC SERVICE ROUTES; AND REPORTING POINTS

- 1. The authority citation for 14 CFR part 71 continues to read as follows:

Authority: 49 U.S.C. 106(f), 106(g), 40103, 40113, 40120; E.O. 10854, 24 FR 9565, 3 CFR, 1959–1963 Comp., p. 389.

§ 71.1 [Amended]

- 2. The incorporation by reference in 14 CFR 71.1 of FAA Order JO 7400.11J, Airspace Designations and Reporting Points, dated July 31, 2024, and effective September 15, 2024, is amended as follows:

Paragraph 6005 Class E Airspace Areas Extending Upward From 700 Feet or More Above the Surface of the Earth.

* * * * *

ANM UT E5 Blanding, UT [Amended]

Blanding Municipal Airport, UT
(Lat. 37°35'00" N, long. 109°28'60" W)

That airspace extending upward from 700 feet above the surface within a 6.2-mile radius of the airport excluding that airspace beyond 3.1 miles west of and parallel to the runway, and within 2.1 miles northwest and 2.9 miles southeast of the airport's 032° bearing extending from the 6.2-mile radius to 11.9 miles northeast.

* * * * *

Issued in Des Moines, Washington, on April 4, 2025.

B.G. Chew,

*Group Manager, Operations Support Group,
Western Service Center.*

[FR Doc. 2025-06111 Filed 4-9-25; 8:45 am]

BILLING CODE 4910-13-P

FEDERAL COMMUNICATIONS COMMISSION

47 CFR Part 73

[MB Docket No. 25-14; RM-11994; DA 25-304; FR ID 288969]

Television Broadcasting Services Monroe, Louisiana

AGENCY: Federal Communications Commission.

ACTION: Final rule.

SUMMARY: This document amends the Table of TV Allotments (table) of the Federal Communications Commission's (Commission) rules by substituting channel *29 for channel *13 at Monroe, Louisiana in response to a Petition for Rulemaking filed by Louisiana Educational Television Authority (LETA), the licensee of noncommercial educational television PBS member station KLTM-TV, channel *13, Monroe, Louisiana. The staff engineering analysis finds that the proposal is in compliance with the Commission's principal community coverage and technical requirements. The substitution of channel *29 for channel *13 in the table will not result in any loss of existing service and it will also allow LETA to remedy its known viewer reception issues on its currently authorized VHF channel.

DATES: Effective April 10, 2025.

FOR FURTHER INFORMATION CONTACT: Emily Harrison, Media Bureau, at Emily.Harrison@fcc.gov, (202) 418-1665, or Mark Colombo, Media Bureau, at Mark.Colombo@fcc.gov, (202) 418-7611.

SUPPLEMENTARY INFORMATION: This is a synopsis of the Commission's *Report and Order*, MB Docket No. 25-14; RM-11994; DA 25-304, adopted April 3, 2025, and released April 3, 2025. The proposed rule was published at 90 FR 10877 on February 28, 2025. The full text of this document is available online at <https://www.fcc.gov/edocs>.

This document does not contain information collection requirements subject to the Paperwork Reduction Act of 1995, Public Law 104-13. In addition, therefore, it does not contain any proposed information collection burden "for small business concerns with fewer than 25 employees," pursuant to the Small Business Paperwork Relief Act of 2002, Public Law 107-198, see 44 U.S.C. 3506(c)(4). Provisions of the Regulatory Flexibility Act of 1980, 5 U.S.C. 601-612, do not apply to this proceeding.

The Commission will send a copy of the *Report and Order* in a report to be sent to Congress and the Government

Accountability Office pursuant to the Congressional Review Act, *see* 5 U.S.C. 801(a)(1)(A).

List of Subjects in 47 CFR Part 73

Television.
Federal Communications Commission.
Thomas Horan,
Chief of Staff, Media Bureau.

Final Rule

For the reasons discussed in the preamble, the Federal Communications Commission amends 47 CFR part 73 as follows:

PART 73—RADIO BROADCAST SERVICES

■ 1. The authority citation for part 73 continues to read as follows:

Authority: 47 U.S.C. 154, 155, 301, 303, 307, 309, 310, 334, 336, 339.

■ 2. In § 73.622, in the table in paragraph (j), under Louisiana, revise the entry for “Monroe” to read as follows:

§ 73.622 Digital television table of allotments.

* * * * *
(j) * * *

Community	Channel No.
* * *	* *
Louisiana	
* * *	* *
Monroe	24, *29
* * *	* *

* * * * *
[FR Doc. 2025-06143 Filed 4-9-25; 8:45 am]
BILLING CODE 6712-01-P

Proposed Rules

Federal Register

Vol. 90, No. 68

Thursday, April 10, 2025

This section of the FEDERAL REGISTER contains notices to the public of the proposed issuance of rules and regulations. The purpose of these notices is to give interested persons an opportunity to participate in the rule making prior to the adoption of the final rules.

DEPARTMENT OF TRANSPORTATION

Federal Aviation Administration

14 CFR Part 39

[Docket No. FAA-2025-0618; Project Identifier AD-2024-00637-T]

RIN 2120-AA64

Airworthiness Directives; The Boeing Company Airplanes

AGENCY: Federal Aviation Administration (FAA), DOT.

ACTION: Notice of proposed rulemaking (NPRM).

SUMMARY: The FAA proposes to adopt a new airworthiness directive (AD) for certain The Boeing Company Model 767-200, -300, -300F, and -400ER series airplanes. This proposed AD was prompted by discovery of a crack at one of the forward lower fastener holes, outside of the underwing longeron (UWL) following replacement of a cracked UWL fitting. This proposed AD would require performing an open hole high frequency eddy current (HFEC) inspection for cracks of the fastener holes common to the UWL fitting, upper drag splice angle, and lower drag splice angle, and applicable on-condition actions. The FAA is proposing this AD to address the unsafe condition on these products.

DATES: The FAA must receive comments on this proposed AD by May 27, 2025.

ADDRESSES: You may send comments, using the procedures found in 14 CFR 11.43 and 11.45, by any of the following methods:

- *Federal eRulemaking Portal:* Go to *regulations.gov*. Follow the instructions for submitting comments.

- *Fax:* 202-493-2251.

- *Mail:* U.S. Department of Transportation, Docket Operations, M-30, West Building Ground Floor, Room W12-140, 1200 New Jersey Avenue SE, Washington, DC 20590.

- *Hand Delivery:* Deliver to Mail address above between 9 a.m. and 5

p.m., Monday through Friday, except Federal holidays.

AD Docket: You may examine the AD docket at *regulations.gov* under Docket No. FAA-2025-0618; or in person at Docket Operations between 9 a.m. and 5 p.m., Monday through Friday, except Federal holidays. The AD docket contains this NPRM, any comments received, and other information. The street address for Docket Operations is listed above.

Material Incorporated by Reference:

- For Boeing material identified in this proposed AD, contact Boeing Commercial Airplanes, Attention: Contractual & Data Services (C&DS), 2600 Westminister Blvd., MC 110-SK57, Seal Beach, CA 90740-5600; telephone 562-797-1717; website *myboeingfleet.com*.

- You may view this material at the FAA, Airworthiness Products Section, Operational Safety Branch, 2200 South 216th St., Des Moines, WA. For information on the availability of this material at the FAA, call 206-231-3195. It is also available at *regulations.gov* under Docket No. FAA-2025-0618.

FOR FURTHER INFORMATION CONTACT: Stefanie Roesli, Aviation Safety Engineer, FAA, 2200 South 216th St., Des Moines, WA 98198; phone: 206-231-3964; email: *Stefanie.N.Roesli@faa.gov*.

SUPPLEMENTARY INFORMATION:

Comments Invited

The FAA invites you to send any written relevant data, views, or arguments about this proposal. Send your comments to an address listed under the **ADDRESSES** section. Include “Docket No. FAA-2025-0618; Project Identifier AD-2024-00637-T” at the beginning of your comments. The most helpful comments reference a specific portion of the proposal, explain the reason for any recommended change, and include supporting data. The FAA will consider all comments received by the closing date and may amend this proposal because of those comments.

Except for Confidential Business Information (CBI) as described in the following paragraph, and other information as described in 14 CFR 11.35, the FAA will post all comments received, without change, to *regulations.gov*, including any personal information you provide. The agency will also post a report summarizing each

substantive verbal contact received about this NPRM.

Confidential Business Information

CBI is commercial or financial information that is both customarily and actually treated as private by its owner. Under the Freedom of Information Act (FOIA) (5 U.S.C. 552), CBI is exempt from public disclosure. If your comments responsive to this NPRM contain commercial or financial information that is customarily treated as private, that you actually treat as private, and that is relevant or responsive to this NPRM, it is important that you clearly designate the submitted comments as CBI. Please mark each page of your submission containing CBI as “PROPIN.” The FAA will treat such marked submissions as confidential under the FOIA, and they will not be placed in the public docket of this NPRM. Submissions containing CBI should be sent to Stefanie Roesli, Aviation Safety Engineer, FAA, 2200 South 216th St., Des Moines, WA 98198; phone: 206-231-3964; email: *Stefanie.N.Roesli@faa.gov*. Any commentary that the FAA receives that is not specifically designated as CBI will be placed in the public docket for this rulemaking.

Background

During an inspection of the UWL fitting in accordance with Boeing Service Bulletin 767-57A0126, Revision 5, dated April 7, 2016, an operator replaced the left side UWL fitting due to a crack found at the flange radius. Subsequent non-destructive inspection of the removed UWL fitting revealed a crack at one of the forward lower fastener holes, outside the inspection area of Service Bulletin 767-57A0126. The crack was 0.30 inch long and 0.37 inch deep. The airplane had accumulated 80,955 total flight hours and 22,620 total flight cycles at the time of the report. An analysis of the cracked fitting found that the crack was caused by fatigue. There is no requirement to inspect the forward lower fastener holes in Service Bulletin 767-57A026 or in the baseline fatigue inspection program per the Boeing 767 Maintenance Planning Data (MPD) Document. A crack in the UWL fitting, if not addressed, could result in loss of the primary load path between the fuselage

and the wing box, adversely affecting the structural integrity of the airplane.

FAA’s Determination

The FAA is issuing this NPRM after determining that the unsafe condition described previously is likely to exist or develop on other products of the same type design.

Material Incorporated by Reference Under 1 CFR Part 51

The FAA reviewed Boeing Alert Requirements Bulletin 767–57A0148 RB, dated October 10, 2024. This material specifies procedures for performing an open hole HFEC inspection for cracks of the fastener holes common to the UWL fitting, upper drag splice angle, and lower drag splice angle, and applicable on-condition actions. On-condition actions include

crack repair (e.g., hole oversize repair), an open hole HFEC inspection of the fitting and angles for any crack at hole oversize repair locations, an open hole HFEC inspection of the entire fastener stack-up common to the tension bolt hole and a surface HFEC inspection of the front spar lower chord for any crack, replacement of the underwing longeron fitting with new underwing longeron fitting, underwing longeron fitting hole repair, tension bolt fastener stack-up repair, front spar lower chord repair, and subsequent repetitive open hole HFEC inspections for cracks of the fastener holes common to the UWL fitting, upper drag splice angle, and lower drag splice angle.

This material is reasonably available because the interested parties have access to it through their normal course

of business or by the means identified in the **ADDRESSES** section.

Proposed AD Requirements in This NPRM

This proposed AD would require accomplishing the actions specified in the material already described, except for any differences identified as exceptions in the regulatory text of this proposed AD. For information on the procedures and compliance times, see this material at *regulations.gov* under Docket No. FAA–2025–0618.

Costs of Compliance

The FAA estimates that this AD, if adopted as proposed, would affect 600 airplanes of U.S. registry. The FAA estimates the following costs to comply with this proposed AD:

ESTIMATED COSTS

Action	Labor cost	Parts cost	Cost per product	Cost on U.S. operators
HFEC inspection of fastener holes	170 work-hours × \$85 per hour = \$14,450 ..	\$0	\$14,450	\$8,670,000

The FAA estimates the following costs to do any necessary on-condition actions that would be required based on

the results of the proposed inspection. The agency has no way of determining

the number of aircraft that might need these repairs:

ON-CONDITION COSTS *

Action	Labor cost	Parts cost	Cost per product
Replacement	19 work-hours × \$85 per hour = \$1,615.	\$15,270	\$16,885.
Inspections of the fitting and angles, the entire fastener stack-up common to the tension bolt hole, and the front spar lower chord for any crack.	Up to 6 work-hours × \$85 = Up to \$510.	0	Up to \$510.
Repetitive HFEC inspection of fastener holes	170 work-hours × \$85 per hour = \$14,450.	0	\$14,450.

* The FAA has received no definitive data on which to base the cost estimates for time and work for the repairs specified in this proposed AD, as the work necessary is variable.

Authority for This Rulemaking

Title 49 of the United States Code specifies the FAA’s authority to issue rules on aviation safety. Subtitle I, section 106, describes the authority of the FAA Administrator. Subtitle VII: Aviation Programs, describes in more detail the scope of the Agency’s authority.

The FAA is issuing this rulemaking under the authority described in Subtitle VII, Part A, Subpart III, Section 44701: General requirements. Under that section, Congress charges the FAA with promoting safe flight of civil aircraft in air commerce by prescribing regulations for practices, methods, and procedures the Administrator finds necessary for safety in air commerce. This regulation is within the scope of

that authority because it addresses an unsafe condition that is likely to exist or develop on products identified in this rulemaking action.

Regulatory Findings

The FAA determined that this proposed AD would not have federalism implications under Executive Order 13132. This proposed AD would not have a substantial direct effect on the States, on the relationship between the national government and the States, or on the distribution of power and responsibilities among the various levels of government.

For the reasons discussed above, I certify this proposed regulation:

(1) Is not a “significant regulatory action” under Executive Order 12866,

(2) Would not affect intrastate aviation in Alaska, and

(3) Would not have a significant economic impact, positive or negative, on a substantial number of small entities under the criteria of the Regulatory Flexibility Act.

List of Subjects in 14 CFR Part 39

Air transportation, Aircraft, Aviation safety, Incorporation by reference, Safety.

The Proposed Amendment

Accordingly, under the authority delegated to me by the Administrator, the FAA proposes to amend 14 CFR part 39 as follows:

PART 39—AIRWORTHINESS DIRECTIVES

■ 1. The authority citation for part 39 continues to read as follows:

Authority: 49 U.S.C. 106(g), 40113, 44701.

§ 39.13 [Amended]

■ 2. The FAA amends § 39.13 by adding the following new airworthiness directive:

The Boeing Company: Docket No. FAA–2025–0618; Project Identifier AD–2024–00637–T.

(a) Comments Due Date

The FAA must receive comments on this airworthiness directive (AD) by May 27, 2025.

(b) Affected ADs

None.

(c) Applicability

This AD applies to The Boeing Company Model 767–200, –300, –300F, and –400ER series airplanes, certificated in any category, as identified in Boeing Alert Requirements Bulletin 767–57A0148 RB, dated October 10, 2024.

(d) Subject

Air Transport Association (ATA) of America Code 57, Wings.

(e) Unsafe Condition

This AD was prompted discovery of a crack at one of the forward lower fastener holes, outside of the underwing longeron (UWL) following replacement of a cracked UWL fitting. The FAA is issuing this AD to ensure that any crack in the forward lower fastener holes at the UWL fitting is found and repaired before reaching a critical length. Such cracking, if not addressed, could result in loss in the primary load path between the fuselage and the wing box, adversely affecting the structural integrity of the airplane.

(f) Compliance

Comply with this AD within the compliance times specified, unless already done.

(g) Required Actions

Except as specified by paragraph (h) of this AD: At the applicable times specified in the “Compliance” paragraph of Boeing Alert Requirements Bulletin 767–57A0148 RB, dated October 10, 2024, do all applicable actions identified in, and in accordance with, the Accomplishment Instructions of Boeing

Alert Requirements Bulletin 767–57A0148 RB, dated October 10, 2024.

Note 1 to paragraph (g): Guidance for accomplishing the actions required by this AD can be found in Boeing Alert Service Bulletin 767–57A0148, dated October 10, 2024, which is referred to in Boeing Alert Requirements Bulletin 767–57A0148 RB, dated October 10, 2024.

(h) Exceptions to Requirements Bulletin Specifications

(1) Where the Compliance Time column of the tables in the “Compliance” paragraph of Boeing Alert Requirements Bulletin 767–57A0148 RB, dated October 10, 2024, refers to the original issue date of Requirements Bulletin 767–57A0148 RB, this AD requires using the effective date of this AD.

(2) Where Boeing Alert Requirements Bulletin 767–57A0148 RB, dated October 10, 2024, specifies contacting Boeing for repair instructions: This AD requires doing the repair using a method approved in accordance with the procedures specified in paragraph (g) of this AD.

(3) During application of any cap seal to a fastener, fastener head, and fastener threads and collars, as required by this AD, the cap seal must be applied with a thickness equal to or greater than the dimensions specified in figure 1 to paragraph (h)(3) of this AD.

Figure 1 to paragraph (h)(3) – Cap seal minimum thickness (all dimensions in inches)

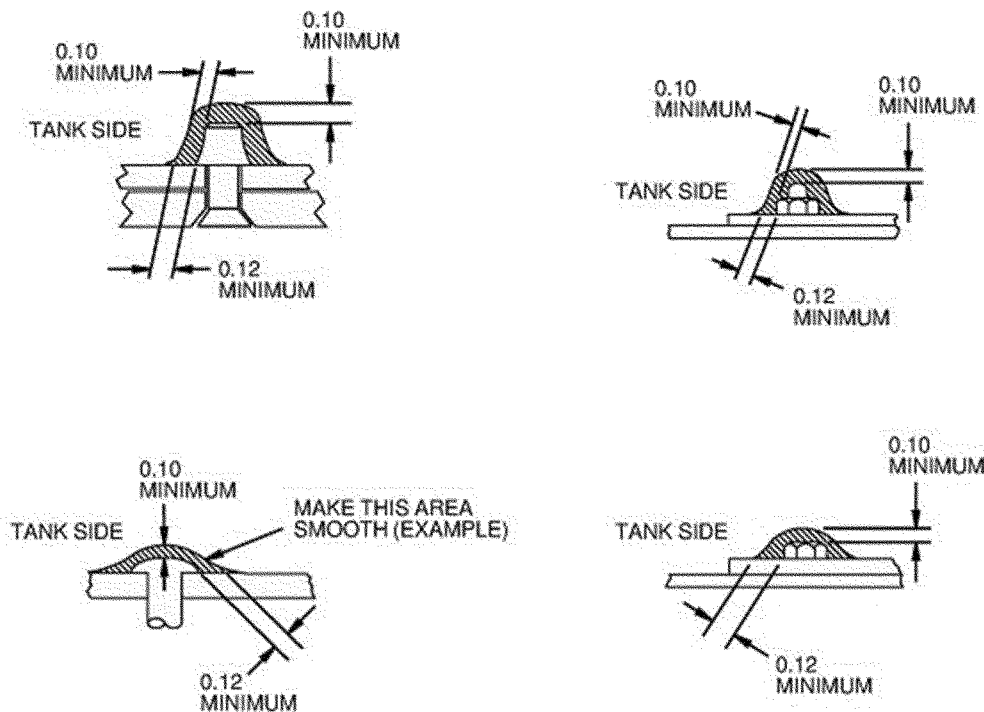

(i) Alternative Methods of Compliance (AMOCs)

(1) The Manager, AIR–520, Continued Operational Safety Branch, FAA, has the authority to approve AMOCs for this AD, if requested using the procedures found in 14

CFR 39.19. In accordance with 14 CFR 39.19, send your request to your principal inspector or responsible Flight Standards Office, as appropriate. If sending information directly to the manager of the certification office, send it to the attention of the person

identified in paragraph (j)(1) of this AD. Information may be emailed to: AMOC@faa.gov.

(2) Before using any approved AMOC, notify your appropriate principal inspector,

or lacking a principal inspector, the manager of the responsible Flight Standards Office.

(3) An AMOC that provides an acceptable level of safety may be used for any repair, modification, or alteration required by this AD if it is approved by The Boeing Company Organization Designation Authorization (ODA) that has been authorized by the Manager, AIR-520, Continued Operational Safety Branch, FAA, to make those findings. To be approved, the repair method, modification deviation, or alteration deviation must meet the certification basis of the airplane, and the approval must specifically refer to this AD.

(j) Related Information

(1) For more information about this AD, contact Stefanie Roesli, Aviation Safety Engineer, FAA, 2200 South 216th St., Des Moines, WA 98198; phone: 206-231-3964; email: Stefanie.N.Roesli@faa.gov.

(2) Material identified in this AD that is not incorporated by reference is available at the address specified in paragraph (k)(3) this AD.

(k) Material Incorporated by Reference

(1) The Director of the Federal Register approved the incorporation by reference of the material listed in this paragraph under 5 U.S.C. 552(a) and 1 CFR part 51.

(2) You must use this material as applicable to do the actions required by this AD, unless the AD specifies otherwise.

(i) Boeing Alert Requirements Bulletin 767-57A0148 RB, dated October 10, 2024.

(ii) [Reserved]

(3) For Boeing material identified in this AD, contact Boeing Commercial Airplanes, Attention: Contractual & Data Services (C&DS), 2600 Westminister Blvd., MC 110-SK57, Seal Beach, CA 90740-5600; telephone 562-797-1717; website myboeingfleet.com.

(4) You may view this material at the FAA, Airworthiness Products Section, Operational Safety Branch, 2200 South 216th St., Des Moines, WA. For information on the availability of this material at the FAA, call 206-231-3195.

(5) You may view this material at the National Archives and Records Administration (NARA). For information on the availability of this material at NARA, visit www.archives.gov/federal-register/cfr/ibr-locations, or email fr.inspection@nara.gov.

Issued on April 3, 2025.

Victor Wicklund,

Deputy Director, Integrated Certificate Management Division, Aircraft Certification Service.

[FR Doc. 2025-06061 Filed 4-9-25; 8:45 am]

BILLING CODE 4910-13-P

DEPARTMENT OF TRANSPORTATION

Federal Aviation Administration

14 CFR Part 39

[Docket No. FAA-2025-0481; Project Identifier AD-2024-00614-T]

RIN 2120-AA64

Airworthiness Directives; The Boeing Company Airplanes

AGENCY: Federal Aviation Administration (FAA), DOT.

ACTION: Notice of proposed rulemaking (NPRM).

SUMMARY: The FAA proposes to supersede Airworthiness Directive (AD) 2023-09-04, which applies to certain The Boeing Company Model 737-600, -700, -700C, -800, -900, and -900ER series airplanes, and certain Model 737-8 and -9 airplanes. AD 2023-09-04 requires inspecting all escape slide assemblies to identify affected parts and replacing affected escape slide assemblies with different assemblies. Since the FAA issued AD 2023-09-04, it was determined that additional airplanes might be affected by the unsafe condition. This proposed AD would retain the requirements of AD 2023-09-04 and require those actions for additional airplanes, including Model 737-8200 airplanes. The FAA is proposing this AD to address the unsafe condition on these products.

DATES: The FAA must receive comments on this proposed AD by May 27, 2025.

ADDRESSES: You may send comments, using the procedures found in 14 CFR 11.43 and 11.45, by any of the following methods:

- *Federal eRulemaking Portal:* Go to regulations.gov. Follow the instructions for submitting comments.
- *Fax:* 202-493-2251.
- *Mail:* U.S. Department of Transportation, Docket Operations, M-30, West Building Ground Floor, Room W12-140, 1200 New Jersey Avenue SE, Washington, DC 20590.
- *Hand Delivery:* Deliver to Mail address above between 9 a.m. and 5 p.m., Monday through Friday, except Federal holidays.

AD Docket: You may examine the AD docket at regulations.gov under Docket No. FAA-2025-0481; or in person at Docket Operations between 9 a.m. and 5 p.m., Monday through Friday, except Federal holidays. The AD docket contains this NPRM, any comments received, and other information. The street address for Docket Operations is listed above.

Material Incorporated by Reference:

- For the Boeing material identified in this proposed AD, contact Boeing Commercial Airplanes, Attention: Contractual & Data Services (C&DS), 2600 Westminister Blvd., MC 110-SK57, Seal Beach, CA 90740-5600; telephone 562-797-1717; website myboeingfleet.com.

- You may view this material at the FAA, Airworthiness Products Section, Operational Safety Branch, 2200 South 216th St., Des Moines, WA. For information on the availability of this material at the FAA, call 206-231-3195. It is also available at regulations.gov under Docket No. FAA-2025-0481.

FOR FURTHER INFORMATION CONTACT: Katherine Venegas, Aviation Safety Engineer, FAA, 3960 Paramount Boulevard, Lakewood, CA 90712; phone: 562-627-5353; email: katherine.venegas@faa.gov.

SUPPLEMENTARY INFORMATION:

Comments Invited

The FAA invites you to send any written relevant data, views, or arguments about this proposal. Send your comments to an address listed under the **ADDRESSES** section. Include “Docket No. FAA-2025-0481; Project Identifier AD-2024-00614-T” at the beginning of your comments. The most helpful comments reference a specific portion of the proposal, explain the reason for any recommended change, and include supporting data. The FAA will consider all comments received by the closing date and may amend this proposal because of those comments.

Except for Confidential Business Information (CBI) as described in the following paragraph, and other information as described in 14 CFR 11.35, the FAA will post all comments received, without change, to regulations.gov, including any personal information you provide. The agency will also post a report summarizing each substantive verbal contact received about this NPRM.

Confidential Business Information

CBI is commercial or financial information that is both customarily and actually treated as private by its owner. Under the Freedom of Information Act (FOIA) (5 U.S.C. 552), CBI is exempt from public disclosure. If your comments responsive to this NPRM contain commercial or financial information that is customarily treated as private, that you actually treat as private, and that is relevant or responsive to this NPRM, it is important that you clearly designate the submitted comments as CBI. Please mark each page of your submission containing CBI

as “PROPIN.” The FAA will treat such marked submissions as confidential under the FOIA, and they will not be placed in the public docket of this NPRM. Submissions containing CBI should be sent to Katherine Venegas, Aviation Safety Engineer, FAA, 3960 Paramount Boulevard, Lakewood, CA 90712; phone: 562-627-5353; email: katherine.venegas@faa.gov. Any commentary that the FAA receives that is not specifically designated as CBI will be placed in the public docket for this rulemaking.

Background

The FAA issued AD 2023-09-04, Amendment 39-22427 (88 FR 33817, May 25, 2023) (AD 2023-09-04), for certain The Boeing Company Model 737-600, -700, -700C, -800, -900, and -900ER series airplanes, and certain Model 737-8 and -9 airplanes. AD 2023-09-04 was prompted by reports of uncommanded escape slide deployments in the passenger compartment while the airplane was on the ground, caused by too much tension in the inflation cable (introduced during packing of the slide) and the movement of the escape slide assembly in the escape slide compartment during normal airplane operations. AD 2023-09-04 requires inspecting all escape slide assemblies to identify affected parts and replacing affected escape slide assemblies with different assemblies. The agency issued AD 2023-09-04 to address inflation of the escape slide while it is in the escape slide compartment, which could result in injury to passengers and crew during normal operation or impede an emergency evacuation by rendering the exit unusable.

Actions Since AD 2023-09-04 Was Issued

Since the FAA issued AD 2023-09-04, the FAA determined that additional airplanes might be affected by the unsafe condition. AD 2023-09-04 applies to airplanes identified by line

number in Boeing Special Attention Requirements Bulletin 737-25-1855 RB, Revision 1, dated April 13, 2022; and Boeing Special Attention Requirements Bulletin 737-25-1866 RB, Revision 1, dated April 11, 2022. However, the FAA has determined that additional line-numbered airplanes, as well as Model 737-8200 airplanes, might have an affected escape slide assembly installed because the part is rotatable. Since the affected parts are rotatable, they could later be installed on airplanes that were initially delivered with acceptable parts, thereby creating an unsafe condition in those airplanes.

In addition, Boeing issued Special Attention Requirements Bulletin 737-25-1866 RB, Revision 2, dated July 19, 2024, to revise the applicable airplanes in the effectivity paragraph of Boeing Special Attention Requirements Bulletin 737-25-1866 RB, Revision 1, dated April 11, 2022.

The FAA proposes to retain the requirements of AD 2023-09-04 and also require that all Model 737-600, -700, -700C, -800, -900, and -900ER series airplanes and Model 737-8, 737-9, and 737-8200 airplanes that are excluded from the applicability of AD 2023-09-04 inspect all escape slide assemblies to identify affected parts and accomplish applicable on-condition actions. The FAA has determined that these actions can be accomplished using Boeing Special Attention Requirements Bulletin 737-25-1855 RB, Revision 1, dated April 13, 2022 (for all Model 737-600, -700, -700C, -800, -900, and -900ER series airplanes); and Boeing Special Attention Requirements Bulletin 737-25-1866 RB, Revision 1, dated April 11, 2022 (for all Model 737-8, 737-9, and 737-8200 airplanes), regardless of whether the airplane model or line number is identified in those bulletins.

FAA’s Determination

The FAA is issuing this NPRM after determining that the unsafe condition described previously is likely to exist or

develop on other products of the same type design.

Material Incorporated by Reference Under 1 CFR Part 51

The FAA reviewed Boeing Special Attention Requirements Bulletin 737-25-1866 RB, Revision 2, dated July 19, 2024. This material specifies procedures for inspecting all escape slide assemblies to identify any escape slide assembly having part number (P/N) 5A3307-7 and replacing it with an assembly having P/N 5A3307-9 or P/N 5A3307-701. Escape slide assembly P/N 5A3307-701 is one on which a firing cable retention has been modified and the assembly reidentified with a new part number.

This proposed AD would also require Boeing Special Attention Requirements Bulletin 737-25-1855 RB, Revision 1, dated April 13, 2022; and Boeing Special Attention Requirements Bulletin 737-25-1866 RB, Revision 1, dated April 11, 2022, which the Director of the Federal Register approved for incorporation by reference as of June 29, 2023 (88 FR 33817, May 25, 2023).

This material is reasonably available because the interested parties have access to it through their normal course of business or by the means identified in the **ADDRESSES** section.

Proposed AD Requirements in This NPRM

This proposed AD would retain all requirements of AD 2023-09-04. This proposed AD would also require those same actions for additional airplanes. For information on the procedures and compliance times, see this material at [regulations.gov](https://www.regulations.gov) under Docket No. FAA-2025-0481.

Costs of Compliance

The FAA estimates that this AD, if adopted as proposed, would affect 2,666 airplanes of U.S. registry. The FAA estimates the following costs to comply with this proposed AD:

ESTIMATED COSTS

Action	Labor cost	Parts cost	Cost per product	Cost on U.S. operators
Inspection or maintenance records review (retained action from AD 2023-09-04).	2 work-hours × \$85 per hour = \$170.	\$0	\$170	\$425,340 (2,502 airplanes).
Inspection or maintenance records review (new proposed action).	2 work-hours × \$85 per hour = \$170.	0	170	\$27,880 (164 airplanes).

The FAA estimates the following costs to do any replacements that would be required based on the results of the

proposed inspection. The agency has no way of determining the number of

aircraft that might need these replacements:

ON-CONDITION COSTS

Action	Labor cost	Parts cost	Cost per product
Replacement	Up to 1 work hour × \$85 per hour = up to \$85.	Up to \$19,000	Up to \$19,085 per escape slide assembly.

Authority for This Rulemaking

Title 49 of the United States Code specifies the FAA's authority to issue rules on aviation safety. Subtitle I, section 106, describes the authority of the FAA Administrator. Subtitle VII: Aviation Programs, describes in more detail the scope of the Agency's authority.

The FAA is issuing this rulemaking under the authority described in Subtitle VII, Part A, Subpart III, Section 44701: General requirements. Under that section, Congress charges the FAA with promoting safe flight of civil aircraft in air commerce by prescribing regulations for practices, methods, and procedures the Administrator finds necessary for safety in air commerce. This regulation is within the scope of that authority because it addresses an unsafe condition that is likely to exist or develop on products identified in this rulemaking action.

Regulatory Findings

The FAA determined that this proposed AD would not have federalism implications under Executive Order 13132. This proposed AD would not have a substantial direct effect on the States, on the relationship between the national government and the States, or on the distribution of power and responsibilities among the various levels of government.

For the reasons discussed above, I certify this proposed regulation:

- (1) Is not a "significant regulatory action" under Executive Order 12866,
- (2) Would not affect intrastate aviation in Alaska, and
- (3) Would not have a significant economic impact, positive or negative, on a substantial number of small entities under the criteria of the Regulatory Flexibility Act.

List of Subjects in 14 CFR Part 39

Air transportation, Aircraft, Aviation safety, Incorporation by reference, Safety.

The Proposed Amendment

Accordingly, under the authority delegated to me by the Administrator, the FAA proposes to amend 14 CFR part 39 as follows:

PART 39—AIRWORTHINESS DIRECTIVES

- 1. The authority citation for part 39 continues to read as follows:

Authority: 49 U.S.C. 106(g), 40113, 44701.

§ 39.13 [Amended]

- 2. The FAA amends § 39.13 by:
 - a. Removing Airworthiness Directive 2023-09-04, Amendment 39-22427 (88 FR 33817, May 25, 2023); and
 - b. Adding the following new airworthiness directive:

The Boeing Company: Docket No. FAA-2025-0481; Project Identifier AD-2024-00614-T.

(a) Comments Due Date

The FAA must receive comments on this airworthiness directive (AD) by May 27, 2025.

(b) Affected ADs

This AD replaces AD 2023-09-04, Amendment 39-22427 (88 FR 33817, May 25, 2023) (AD 2023-09-04).

(c) Applicability

This AD applies to The Boeing Company Model 737-600, -700, -700C, -800, -900, and -900ER series airplanes, and Model 737-8, 737-9, and 737-8200 airplanes, certificated in any category.

(d) Subject

Air Transport Association (ATA) of America Code 25, Equipment/furnishings.

(e) Unsafe Condition

This AD was prompted by reports of uncommanded escape slide deployments in the passenger compartment, caused by too much tension in the inflation cable and the movement of the escape slide assembly in the escape slide compartment. The FAA is issuing this AD to address inflation of the escape slide while it is in the escape slide compartment, which could result in injury to passengers and crew during normal operation, or impede an emergency evacuation by rendering the exit unusable.

(f) Compliance

Comply with this AD within the compliance times specified, unless already done.

(g) Retained Inspection, With No Changes

This paragraph restates the requirements of paragraph (g) of AD 2023-09-04, with no changes. For airplanes identified in Boeing Special Attention Requirements Bulletin 737-25-1855 RB, Revision 1, dated April 13, 2022; and Boeing Special Attention Requirements Bulletin 737-25-1866 RB,

Revision 1, dated April 11, 2022: Except as specified in paragraph (i) of this AD, at the applicable times specified in the "Compliance" paragraph of Boeing Special Attention Requirements Bulletin 737-25-1855 RB, Revision 1, dated April 13, 2022, and Boeing Special Attention Requirements Bulletin 737-25-1866 RB, Revision 1, dated April 11, 2022, do all applicable actions identified in, and in accordance with, the Accomplishment Instructions of Boeing Special Attention Requirements Bulletin 737-25-1855 RB, Revision 1, dated April 13, 2022 (for Model 737-600, -700, -700C, -800, -900, and -900ER series airplanes); and Boeing Special Attention Requirements Bulletin 737-25-1866 RB, Revision 1, dated April 11, 2022 (for Model 737-8 and -9 airplanes); as applicable.

Note 1 to paragraph (g): Guidance for accomplishing the actions required by paragraph (g) of this AD can be found in Boeing Special Attention Service Bulletin 737-25-1855, Revision 1, dated April 13, 2022, which is referred to in Boeing Special Attention Requirements Bulletin 737-25-1855 RB, Revision 1, dated April 13, 2022.

Note 2 to paragraph (g): Guidance for accomplishing the actions required by paragraph (g) of this AD can be found in Boeing Special Attention Service Bulletin 737-25-1866, Revision 1, dated April 11, 2022, which is referred to in Boeing Special Attention Requirements Bulletin 737-25-1866 RB, Revision 1, dated April 11, 2022.

(h) New Required Actions

For airplanes not identified in Boeing Special Attention Requirements Bulletin 737-25-1855 RB, Revision 1, dated April 13, 2022; or Boeing Special Attention Requirements Bulletin 737-25-1866 RB, Revision 1, dated April 11, 2022: Except as specified in paragraph (i) of this AD, at the applicable times specified in the "Compliance" paragraph of Boeing Special Attention Requirements Bulletin 737-25-1855 RB, Revision 1, dated April 13, 2022, and Boeing Special Attention Requirements Bulletin 737-25-1866 RB, Revision 2, dated July 19, 2024, do all applicable actions identified in, and in accordance with, the Accomplishment Instructions of Boeing Special Attention Requirements Bulletin 737-25-1855 RB, Revision 1, dated April 13, 2022 (for Model 737-600, -700, -700C, -800, -900, and -900ER series airplanes), and Boeing Special Attention Requirements Bulletin 737-25-1866 RB, Revision 2, dated July 19, 2024 (for Model 737-8, 737-9, and 737-8200 airplanes); as applicable.

Note 3 to paragraph (h): Guidance for accomplishing the actions required by paragraph (h) of this AD can be found in Boeing Special Attention Service Bulletin 737-25-1855, Revision 1, dated April 13, 2022, which is referred to in Boeing Special

Attention Requirements Bulletin 737–25–1855 RB, Revision 1, dated April 13, 2022.

Note 4 to paragraph (h): Guidance for accomplishing the actions required by paragraph (h) of this AD can be found in Boeing Special Attention Service Bulletin 737–25–1866, Revision 2, dated July 19, 2024, which is referred to in Boeing Special Attention Requirements Bulletin 737–25–1866 RB, Revision 2, dated July 19, 2024.

(i) Exceptions to Requirements Bulletin Specifications

(1) For paragraph (g) of this AD: Where the Compliance Time columns of the tables in the “Compliance” paragraph of Boeing Special Attention Requirements Bulletin 737–25–1855 RB, Revision 1, dated April 13, 2022, use the phrase “the Original Issue date of Requirements Bulletin 737–25–1855 RB,” this AD requires using June 29, 2023 (the effective date of AD 2023–09–04).

(2) For paragraph (g) of this AD: Where the Compliance Time columns of the tables in the “Compliance” paragraph of Boeing Special Attention Requirements Bulletin 737–25–1866 RB, Revision 1, dated April 11, 2022, use the phrase “the Original Issue date of Requirements Bulletin 737–25–1866 RB,” this AD requires using June 29, 2023 (the effective date of AD 2023–09–04).

(3) For paragraph (h) of this AD: Where the Compliance Time columns of the tables in the “Compliance” paragraph of Boeing Special Attention Requirements Bulletin 737–25–1855 RB, Revision 1, dated April 13, 2022, use the phrase “the Original Issue date of Requirements Bulletin 737–25–1855 RB,” this AD requires using the effective date of this AD.

(4) For paragraph (h) of this AD: Where the Compliance Time columns of the tables in the “Compliance” paragraph of Boeing Special Attention Requirements Bulletin 737–25–1866 RB, Revision 2, dated July 19, 2024, use the phrase “the Original Issue date of Requirements Bulletin 737–25–1866 RB,” this AD requires using the effective date of this AD.

(5) Where Boeing Special Attention Requirements Bulletin 737–25–1855 RB, Revision 1, dated April 13, 2022; Boeing Special Attention Requirements Bulletin 737–25–1866 RB, Revision 1, dated April 11, 2022; and Boeing Special Attention Requirements Bulletin 737–25–1866 RB, Revision 2, dated July 19, 2024, specify doing an inspection of the escape slide assembly to determine whether P/N 5A3307–7 is installed, for this AD a review of airplane maintenance records is acceptable in lieu of this inspection, provided the part number of the escape slide assembly can be conclusively determined from that review.

(j) Credit for Previous Actions

(1) This paragraph provides credit for the actions specified in paragraph (g) of this AD, if those actions were performed before June 29, 2023 (the effective date of AD 2023–09–04) using Boeing Special Attention Requirements Bulletin 737–25–1855 RB, dated August 31, 2021, or Boeing Special Attention Requirements Bulletin 737–25–1866 RB, dated September 27, 2021, as applicable.

(2) This paragraph provides credit for the actions specified in paragraph (h) of this AD, if those actions were performed before the effective date of this AD using Boeing Special Attention Requirements Bulletin 737–25–1855 RB, dated August 31, 2021; Boeing Special Attention Requirements Bulletin 737–25–1866 RB, dated September 27, 2021; or Boeing Special Attention Requirements Bulletin 737–25–1866 RB, Revision 1, dated April 11, 2022; as applicable.

(k) Alternative Methods of Compliance (AMOCs)

(1) The Manager, AIR–520, Continued Operational Safety Branch, FAA, has the authority to approve AMOCs for this AD, if requested using the procedures found in 14 CFR 39.19. In accordance with 14 CFR 39.19, send your request to your principal inspector or responsible Flight Standards Office, as appropriate. If sending information directly to the manager of the certification office, send it to the attention of the person identified in paragraph (l)(1) of this AD. Information may be emailed to: AMOC@faa.gov.

(2) Before using any approved AMOC, notify your appropriate principal inspector, or lacking a principal inspector, the manager of the responsible Flight Standards Office.

(3) An AMOC that provides an acceptable level of safety may be used for any repair, modification, or alteration required by this AD if it is approved by The Boeing Company Organization Designation Authorization (ODA) that has been authorized by the Manager, AIR–520, Continued Operational Safety Branch, FAA, to make those findings. To be approved, the repair method, modification deviation, or alteration deviation must meet the certification basis of the airplane, and the approval must specifically refer to this AD.

(4) AMOCs approved for AD 2023–09–04 are approved as AMOCs for the corresponding provisions of paragraph (g) of this AD.

(l) Related Information

(1) For more information about this AD, contact Katherine Venegas, Aviation Safety Engineer, FAA, 3960 Paramount Boulevard, Lakewood, CA 90712; phone: 562–627–5353; email: katherine.venegas@faa.gov.

(2) Material identified in this AD that is not incorporated by reference is available at the address specified in paragraph (m)(5) this AD.

(m) Material Incorporated by Reference

(1) The Director of the Federal Register approved the incorporation by reference (IBR) of the material listed in this paragraph under 5 U.S.C. 552(a) and 1 CFR part 51.

(2) You must use this material as applicable to do the actions required by this AD, unless the AD specifies otherwise.

(3) The following material was approved for IBR on [DATE 35 DAYS AFTER PUBLICATION OF THE FINAL RULE].

(i) Boeing Special Attention Requirements Bulletin 737–25–1866 RB, Revision 2, dated July 19, 2024.

(ii) [Reserved]

(4) The following material was approved for IBR on June 29, 2023 (88 FR 33817, May 25, 2023).

(i) Boeing Special Attention Requirements Bulletin 737–25–1855 RB, Revision 1, dated April 13, 2022.

(ii) Boeing Special Attention Requirements Bulletin 737–25–1866 RB, Revision 1, dated April 11, 2022.

(5) For the material identified in this AD, contact Boeing Commercial Airplanes, Attention: Contractual & Data Services (C&DS), 2600 Westminster Blvd., MC 110–SK57, Seal Beach, CA 90740–5600; telephone 562–797–1717; website myboeingfleet.com.

(6) You may view this material at the FAA, Airworthiness Products Section, Operational Safety Branch, 2200 South 216th St., Des Moines, WA. For information on the availability of this material at the FAA, call 206–231–3195.

(7) You may view this material at the National Archives and Records Administration (NARA). For information on the availability of this material at NARA, visit www.archives.gov/federal-register/cfr/ibr-locations or email fr.inspection@nara.gov.

Issued on March 24, 2025.

Victor Wicklund,

Deputy Director, Integrated Certificate Management Division, Aircraft Certification Service.

[FR Doc. 2025–06123 Filed 4–9–25; 8:45 am]

BILLING CODE 4910–13–P

CONSUMER PRODUCT SAFETY COMMISSION

16 CFR Chapter II

[Docket No. CPSC–2025–0006]

Petition Requesting a Mandatory Regulation for Child-Resistant Above-Ground and Portable Pool Ladders

AGENCY: Consumer Product Safety Commission.

ACTION: Request for comment on petition.

SUMMARY: The Consumer Product Safety Commission (Commission or CPSC) has received a petition requesting that the Commission establish a regulation for child-resistant above-ground and portable pool ladders to reduce the drowning deaths of children younger than 5 years of age, and particularly children between 1 and 3 years. The Commission invites written comments concerning the petition.

DATES: Submit comments by June 9, 2025.

ADDRESSES: You can submit comments, identified by Docket No. CPSC–2025–0006, by any of the following methods:

Electronic Submissions: Submit electronic comments to the Federal eRulemaking Portal at:

www.regulations.gov. Follow the instructions for submitting comments. Do not submit through this website: confidential business information, trade secret information, or other sensitive or protected information that you do not want to be available to the public. CPSC typically does not accept comments submitted by email, except as described below.

Mail/Hand Delivery/Courier/Confidential Written Submissions: CPSC encourages you to submit electronic comments by using the Federal eRulemaking Portal. You may, however, submit comments by mail, hand delivery, or courier to: Office of the Secretary, Consumer Product Safety Commission, 4330 East-West Highway, Bethesda, MD 20814; telephone: (301) 504-7479. If you wish to submit confidential business information, trade secret information, or other sensitive or protected information that you do not want available to the public, you may submit such comments by mail, hand delivery, courier, or you may email them to: cpsc-os@cpsc.gov.

Instructions: All submissions must include the agency name and docket number. CPSC may post all comments without change, including any personal identifiers, contact information, or other personal information provided, to: www.regulations.gov. Do not submit to this website: confidential business information, trade secret information, or other sensitive or protected information that you do not want to be available to the public. If you wish to submit such information, please submit it according to the instructions for mail/hand delivery/courier/confidential written submissions.

Docket: For access to the docket to read background documents or comments received, go to: www.regulations.gov, and insert the docket number, CPSC-2025-0006, into the "Search" box, and follow the prompts.

FOR FURTHER INFORMATION CONTACT: Alberta E. Mills, Office of the Secretary, Consumer Product Safety Commission, 4330 East-West Highway, Bethesda, MD 20814; telephone: 301-504-7479; email: cpsc-os@cpsc.gov.

SUPPLEMENTARY INFORMATION: On January 22, 2025, Carol Pollack-Nelson, Ph.D., of Independent Safety Consulting, LLC (Petitioner), submitted a petition requesting that the Commission establish a mandatory regulation for child-resistant above-ground and portable pool ladders to

reduce the drowning deaths of children younger than 5 years of age, and particularly children between 1 and 3 years, the age group asserted to be at greatest risk.

The Petitioner notes that two voluntary standards are relevant to this petition: (1) ASTM Standard Specification for Aboveground Portable Pools for Residential Use, ASTM F2666-16; and (2) ANSI/APSP/ICC-4 2012 American National Standard for Aboveground/Onground Residential Pools. ASTM F2666-16 covers all types of portable pools with a water depth of less than 36 inches (91 cm). ANSI/APSP-4 pertains to aboveground/onground residential swimming pools with a water depth of 36 inches (91 cm) or greater.

The Petitioner asserts that since 2016, the ASTM voluntary standard for portable pools, ASTM F2666-16, Safety Specification for Aboveground Portable Pools for Residential Use,¹ has included a "general requirement" for child resistance on pool ladders. The requirement in section 5.1 of ASTM F2666-16 states, "Any ladders sold with or for use with Type A² or Type B³ pools shall meet all the applicable requirements found in ANSI/APSP-4 and be child resistant to the degree of preventing unauthorized access for children under the age of five years." ANSI/APSP-4, American National Standard for Aboveground/Onground Residential Swimming Pools, contains requirements for ladder warnings and performance standards.⁴ However, the Petitioner states that there is no protocol or metric required to verify that a ladder is child-resistant. Rather, section 5.1 of the voluntary standard states: "Verification can be satisfied by document review." The Petitioner also asserts that above-ground pools (having a side height measuring at least 36 inches) are much more likely to be

¹ ASTM F2666-16 defines a "portable pool" as "any movable structure with the intended purpose of being used for swimming or other water recreation by consumers, and having a water depth (at the fill line) less than 36 in. (91 cm)." F2666-16, sec. 3.1.6. A copy of ASTM F2666-16 may be purchased from ASTM through its website, www.astm.org.

² Section 4.1.1 of the standard defines Type A pools as "Pools with no means of water circulation or water treatment during or after use. Such pools include but are not limited to wading pools, splash pools, and kiddie pools."

³ Section 4.1.2 of the standard defines Type B pools as "Pools that are provided with a means or connection provisions to add equipment for circulation and filtration of water."

⁴ A copy of ANSI/APSP-4 may be purchased from ANSI through its website, webstore.ansi.org.

involved in child drownings than portable pools.

The Petitioner asserts, based on a review and analysis of CPSC In-Depth Investigations and CPSC data regarding nonfatal drowning injuries and deaths related to pools, that child-resistant ladders are necessary to mitigate the risk of drowning from children's access to above-ground and portable pools. Therefore, the Petitioner requests that CPSC develop a regulation that will require child-resistance for all pool ladders sold with, or for, above-ground or portable pools to mitigate the risk of drowning. Specifically, the Petitioner requests the Commission promulgate a mandatory regulation to establish: (1) a child-resistance requirement for A-frame and other ladders intended for above-ground and portable pools; and (2) an objective and measurable definition of "child-resistant."

The Commission seeks comment from the public concerning this petition as well as any studies or data pertaining to child-resistance for ladders intended to be used with above-ground and portable pools.⁵ To the extent possible, commenters should provide specific information, including reference to known documentation, engineering studies, technical studies, reports of injuries, medical findings, legal analyses, economic analyses, and environmental impact analyses.

The major factors the Commission considers in deciding whether to grant or deny a petition regarding a product include:

(1) Whether the product presents an unreasonable risk of injury.

(2) Whether a rule is reasonably necessary to eliminate or reduce the risk of injury.

(3) Whether failure to initiate the requested rulemaking proceeding would unreasonably expose the petitioner or other consumers to the risk of injury which the petitioner alleges is presented by the product.

16 CFR 1051.9(a).

In considering these factors, the Commission will consider the relative priority of the risk of injury associated with the product at issue and the Commission's available resources. 16 CFR 1051.9(b). The CPSC Policy on Establishing Priorities for Commission Action, 16 CFR 1009.8, sets forth the criteria upon which Commission priorities are based.

⁵ The Commission voted 5-0 to approve publication of this notice.

The petition is available at: <http://www.regulations.gov>, under Docket No. CPSC-2025-0006, Supporting and Related Materials. Alternatively, interested parties may obtain a copy of

the petition by writing or calling the Office of the Secretary, Consumer Product Safety Commission, 4330 East-West Highway, Bethesda, MD 20814;

telephone (301) 504-7479; email: cpsc-os@cpsc.gov.

Alberta E. Mills,
Secretary, U.S. Consumer Product Safety Commission.

[FR Doc. 2025-06125 Filed 4-9-25; 8:45 am]

BILLING CODE 6355-01-P

Notices

Federal Register

Vol. 90, No. 68

Thursday, April 10, 2025

This section of the FEDERAL REGISTER contains documents other than rules or proposed rules that are applicable to the public. Notices of hearings and investigations, committee meetings, agency decisions and rulings, delegations of authority, filing of petitions and applications and agency statements of organization and functions are examples of documents appearing in this section.

ACTION: Notice.

SUMMARY: The Civil Rights Cold Case Records Review Board received 212 pages of records from the National Archives and Records Administration (NARA), the Department of Justice, and the Federal Bureau of Investigation (FBI) related to a civil rights cold case incident to which the Review Board assigned the unique identifier 2023-001-002. NARA did not propose any postponements of disclosure. The Department of Justice and the FBI proposed 471 postponements of disclosure. The Department of Justice later withdrew two postponements it proposed. On March 28, 2025, the Review Board met and approved 186 postponements, requested changes to 26 postponements, and determined that

168 pages in full and 44 pages in part should be publicly disclosed in the Civil Rights Cold Case Records Collection. By issuing this notice, the Review Board complies with section 7(c)(4) of the Civil Rights Cold Case Records Collection Act of 2018 that requires the Review Board to publish in the **Federal Register** its determinations on the disclosure or postponement of records in the Collection no more than 14 days after the date of its decision.

FOR FURTHER INFORMATION CONTACT: Stephannie Oriabure, Chief of Staff, Civil Rights Cold Case Records Review Board, 1800 F Street NW, Washington, DC 20405, (771) 221-0014, *info@coldcaserecords.gov*.

SUPPLEMENTARY INFORMATION:

CIVIL RIGHTS COLD CASE RECORDS REVIEW BOARD

[Agency Docket Number: CRCCRRB-2025-0012-N]

Notice of Formal Determination on Records Release

AGENCY: Civil Rights Cold Case Records Review Board.

Incident identifier	Postponement identifier	Review board decision
2023-001-002	2024-DOJ-01-0001	Approve with changes.
2023-001-002	2024-DOJ-01-0002 and 2024-DOJ-01-0003	Approve.
2023-001-002	2024-DOJ-01-0004 through 2024-DOJ-01-0006	Reject.
2023-001-002	2024-DOJ-01-0007	Approve.
2023-001-002	2024-DOJ-01-0008 through 2024-DOJ-01-0011	Reject.
2023-001-002	2024-DOJ-01-0012 through 2024-DOJ-01-0014	Approve.
2023-001-002	2024-DOJ-01-0015	Approve with changes.
2023-001-002	2024-DOJ-01-0016	Approve.
2023-001-002	2024-DOJ-01-0017 and 2024-DOJ-01-0018	Withdrawn by agency.
2023-001-002	2024-DOJ-01-0019 through 2024-DOJ-01-0021	Approve.
2023-001-002	2024-DOJ-01-0022 and 2024-DOJ-01-0023	Reject.
2023-001-002	2024-FBI-01-0001 and 2024-FBI-01-0002	Reject.
2023-001-002	2024-FBI-01-0003 and 2024-FBI-01-0004	Approve.
2023-001-002	2024-FBI-01-0005 and 2024-FBI-01-0006	Reject.
2023-001-002	2024-FBI-01-0007 through 2024-FBI-01-0011	Approve.
2023-001-002	2024-FBI-01-0012	Approve with changes.
2023-001-002	2024-FBI-01-0013	Reject.
2023-001-002	2024-FBI-01-0014 through 2024-FBI-01-0017	Approve.
2023-001-002	2024-FBI-01-0018	Reject.
2023-001-002	2024-FBI-01-0019 through 2024-FBI-01-0028	Approve.
2023-001-002	2024-FBI-01-0029	Reject.
2023-001-002	2024-FBI-01-0030	Approve.
2023-001-002	2024-FBI-01-0031	Approve with changes.
2023-001-002	2024-FBI-01-0032 through 2024-FBI-01-0035	Approve.
2023-001-002	2024-FBI-01-0036	Approve with changes.
2023-001-002	2024-FBI-01-0037	Approve.
2023-001-002	2024-FBI-01-0038	Approve with changes.
2023-001-002	2024-FBI-01-0039 and 2024-FBI-01-0040	Approve.
2023-001-002	2024-FBI-01-0041	Approve with changes.
2023-001-002	2024-FBI-01-0042	Approve.
2023-001-002	2024-FBI-01-0043	Approve with changes.
2023-001-002	2024-FBI-01-0044 through 2024-FBI-01-0046	Approve.
2023-001-002	2024-FBI-01-0047 through 2024-FBI-01-0051	Reject.
2023-001-002	2024-FBI-01-0052	Approve.
2023-001-002	2024-FBI-01-0053 through 2024-FBI-01-0056	Reject.
2023-001-002	2024-FBI-01-0057 through 2024-FBI-01-0060	Approve.
2023-001-002	2024-FBI-01-0061	Reject.
2023-001-002	2024-FBI-01-0062 through 2024-FBI-01-0071	Approve.
2023-001-002	2024-FBI-01-0072	Reject.
2023-001-002	2024-FBI-01-0073	Approve.
2023-001-002	2024-FBI-01-0074	Approve with changes.
2023-001-002	2024-FBI-01-0075 through 2024-FBI-01-0086	Reject.
2023-001-002	2024-FBI-01-0087	Approve.

Incident identifier	Postponement identifier	Review board decision
2023-001-002	2024-FBI-01-0088 through 2024-FBI-01-0105	Reject.
2023-001-002	2024-FBI-01-0106	Approve.
2023-001-002	2024-FBI-01-0107 through 2024-FBI-01-0110	Reject.
2023-001-002	2024-FBI-01-0111 through 2024-FBI-01-0114	Approve.
2023-001-002	2024-FBI-01-0115	Reject.
2023-001-002	2024-FBI-01-0116 through 2024-FBI-01-0124	Approve.
2023-001-002	2024-FBI-01-0125	Reject.
2023-001-002	2024-FBI-01-0126	Approve with changes.
2023-001-002	2024-FBI-01-0127	Approve.
2023-001-002	2024-FBI-01-0128 through 2024-FBI-01-0140	Reject.
2023-001-002	2024-FBI-01-0141	Approve.
2023-001-002	2024-FBI-01-0142 through 2024-FBI-01-0181	Reject.
2023-001-002	2024-FBI-01-0182 through 2024-FBI-01-0209	Reject.
2023-001-002	2024-FBI-01-0210	Approve.
2023-001-002	2024-FBI-01-0211 through 2024-FBI-01-0217	Reject.
2023-001-002	2024-FBI-01-0218	Approve.
2023-001-002	2024-FBI-01-0219 and 2024-FBI-01-0220	Reject.
2023-001-002	2024-FBI-01-0221 and 2024-FBI-01-0222	Approve.
2023-001-002	2024-FBI-01-0223 and 2024-FBI-01-0224	Reject.
2023-001-002	2024-FBI-01-0225	Approve with changes.
2023-001-002	2024-FBI-01-0226 and 2024-FBI-01-0227	Approve.
2023-001-002	2024-FBI-01-0228	Reject.
2023-001-002	2024-FBI-01-0229	Approve with changes.
2023-001-002	2024-FBI-01-0230 through 2024-FBI-01-0232	Approve.
2023-001-002	2024-FBI-01-0233	Approve with changes.
2023-001-002	2024-FBI-01-0234 through 2024-FBI-01-0237	Approve.
2023-001-002	2024-FBI-01-0238	Approve with changes.
2023-001-002	2024-FBI-01-0239 and 2024-FBI-01-0240	Approve.
2023-001-002	2024-FBI-01-0241	Reject.
2023-001-002	2024-FBI-01-0242 and 2024-FBI-01-0243	Approve with changes.
2023-001-002	2024-FBI-01-0244 and 2024-FBI-01-0245	Approve.
2023-001-002	2024-FBI-01-0246 and 2024-FBI-01-0247	Reject.
2023-001-002	2024-FBI-01-0248	Approve with changes.
2023-001-002	2024-FBI-01-0249 through 2024-FBI-01-0251	Approve.
2023-001-002	2024-FBI-01-0252	Approve with changes.
2023-001-002	2024-FBI-01-0253 through 2024-FBI-01-0256	Approve.
2023-001-002	2024-FBI-01-0257 and 2024-FBI-01-0258	Reject.
2023-001-002	2024-FBI-01-0259	Approve with changes.
2023-001-002	2024-FBI-01-0260 and 2024-FBI-01-0261	Approve.
2023-001-002	2024-FBI-01-0262 and 2024-FBI-01-0263	Reject.
2023-001-002	2024-FBI-01-0264	Approve with changes.
2023-001-002	2024-FBI-01-0265 through 2024-FBI-01-0267	Approve.
2023-001-002	2024-FBI-01-0268 and 2024-FBI-01-0269	Reject.
2023-001-002	2024-FBI-01-0270	Approve with changes.
2023-001-002	2024-FBI-01-0271	Approve.
2023-001-002	2024-FBI-01-0272	Reject.
2023-001-002	2024-FBI-01-0273	Approve.
2023-001-002	2024-FBI-01-0274 through 2024-FBI-01-0280	Reject.
2023-001-002	2024-FBI-01-0281	Approve.
2023-001-002	2024-FBI-01-0282 and 2024-FBI-01-0283	Reject.
2023-001-002	2024-FBI-01-0284 and 2024-FBI-01-0285	Approve.
2023-001-002	2024-FBI-01-0286 and 2024-FBI-01-0287	Reject.
2023-001-002	2024-FBI-01-0288	Approve with changes.
2023-001-002	2024-FBI-01-0289 and 2024-FBI-01-0290	Approve.
2023-001-002	2024-FBI-01-0291 and 2024-FBI-01-0292	Reject.
2023-001-002	2024-FBI-01-0293	Approve with changes.
2023-001-002	2024-FBI-01-0294 through 2024-FBI-01-0297	Approve.
2023-001-002	2024-FBI-01-0298 and 2024-FBI-01-0299	Approve with changes.
2023-001-002	2024-FBI-01-0300 through 2024-FBI-01-0302	Approve.
2023-001-002	2024-FBI-01-0303	Approve with changes.
2023-001-002	2024-FBI-01-0304 and 2024-FBI-01-0305	Approve.
2023-001-002	2024-FBI-01-0306 and 2024-FBI-01-0307	Reject.
2023-001-002	2024-FBI-01-0308 through 2024-FBI-01-0311	Approve.
2023-001-002	2024-FBI-01-0312 and 2024-FBI-01-0313	Reject.
2023-001-002	2024-FBI-01-0314	Approve.
2023-001-002	2024-FBI-01-0315	Approve with changes.
2023-001-002	2024-FBI-01-0316 through 2024-FBI-01-0319	Approve.
2023-001-002	2024-FBI-01-0320 and 2024-FBI-01-0321	Reject.
2023-001-002	2024-FBI-01-0322 through 2024-FBI-01-0325	Approve.
2023-001-002	2024-FBI-01-0326 and 2024-FBI-01-0327	Reject.
2023-001-002	2024-FBI-01-0328	Approve.
2023-001-002	2024-FBI-01-0329	Reject.
2023-001-002	2024-FBI-01-0330 and 2024-FBI-01-0331	Approve.
2023-001-002	2024-FBI-01-0332 and 2024-FBI-01-0333	Reject.

Incident identifier	Postponement identifier	Review board decision
2023-001-002	2024-FBI-01-0334	Approve.
2023-001-002	2024-FBI-01-0335	Reject.
2023-001-002	2024-FBI-01-0336 through 2024-FBI-01-0338	Approve.
2023-001-002	2024-FBI-01-0339 and 2024-FBI-01-0340	Reject.
2023-001-002	2024-FBI-01-0341	Approve.
2023-001-002	2024-FBI-01-0342	Reject.
2023-001-002	2024-FBI-01-0343	Approve.
2023-001-002	2024-FBI-01-0344 through 2024-FBI-01-0346	Reject.
2023-001-002	2024-FBI-01-0347	Approve.
2023-001-002	2024-FBI-01-0348 through 2024-FBI-01-0351	Reject.
2023-001-002	2024-FBI-01-0352	Approve.
2023-001-002	2024-FBI-01-0353 and 2024-FBI-01-0354	Reject.
2023-001-002	2024-FBI-01-0355	Approve.
2023-001-002	2024-FBI-01-0356	Approve with changes.
2023-001-002	2024-FBI-01-0357	Approve.
2023-001-002	2024-FBI-01-0358	Reject.
2023-001-002	2024-FBI-01-0359 and 2024-FBI-01-0360	Approve.
2023-001-002	2024-FBI-01-0361 and 2024-FBI-01-0362	Reject.
2023-001-002	2024-FBI-01-0363	Approve.
2023-001-002	2024-FBI-01-0364 through 2024-FBI-01-0368	Reject.
2023-001-002	2024-FBI-01-0369	Approve.
2023-001-002	2024-FBI-01-0370 through 2024-FBI-01-0379	Reject.
2023-001-002	2024-FBI-01-0380 through 2024-FBI-01-0383	Approve.
2023-001-002	2024-FBI-01-0384	Reject.
2023-001-002	2024-FBI-01-0385 through 2024-FBI-01-0394	Approve.
2023-001-002	2024-FBI-01-0395	Reject.
2023-001-002	2024-FBI-01-0396	Approve.
2023-001-002	2024-FBI-01-0397	Approve with changes.
2023-001-002	2024-FBI-01-0398	Approve.
2023-001-002	2024-FBI-01-0399 through 2024-FBI-01-0411	Reject.
2023-001-002	2024-FBI-01-0412	Approve.
2023-001-002	2024-FBI-01-0413 through 2024-FBI-01-0422	Reject.
2023-001-002	2024-FBI-01-0423	Approve.
2023-001-002	2024-FBI-01-0424 through 2024-FBI-01-0426	Reject.
2023-001-002	2024-FBI-01-0427	Approve.
2023-001-002	2024-FBI-01-0428 and 2024-FBI-01-0429	Reject.
2023-001-002	2024-FBI-01-0430	Approve.
2023-001-002	2024-FBI-01-0431 through 2024-FBI-01-0435	Reject.
2023-001-002	2024-FBI-01-0436 and 2024-FBI-01-0437	Approve.
2023-001-002	2024-FBI-01-0438	Reject.
2023-001-002	2024-FBI-01-0439 through 2024-FBI-01-0444	Approve.
2023-001-002	2024-FBI-01-0445	Reject.
2023-001-002	2024-FBI-01-0446 and 2024-FBI-01-0447	Approve.
2023-001-002	2024-FBI-01-0448	Reject.

Authority: Pub. L. 115-426, 132 Stat. 5489 (44 U.S.C. 2107).

Dated: April 4, 2025.

Stephannie Oriabure,
Chief of Staff.

[FR Doc. 2025-06108 Filed 4-9-25; 8:45 am]

BILLING CODE 6820-SY-P

DEPARTMENT OF COMMERCE

Foreign-Trade Zones Board

[B-22-2025]

Foreign-Trade Zone (FTZ) 20, Notification of Proposed Production Activity; LMF AKRO, LLC; (Wooden Attic Stair Products); Elizabeth City, North Carolina

LMFAKRO, LLC submitted a notification of proposed production activity to the FTZ Board (the Board) for

its facility in Elizabeth City, North Carolina within FTZ 20. The notification conforming to the requirements of the Board's regulations (15 CFR 400.22) was received on April 3, 2025.

Pursuant to 15 CFR 400.14(b), FTZ production activity would be limited to the specific foreign-status material(s)/ component(s) and specific finished product(s) described in the submitted notification (summarized below) and subsequently authorized by the Board. The benefits that may stem from conducting production activity under FTZ procedures are explained in the background section of the Board's website—accessible via www.trade.gov/ftz.

The proposed finished products include: wooden attic stairs (duty rate 3.2%).

The proposed foreign-status materials/components include:

crossbars (22.5 inches to 30 inches); steel brackets; steel flat bar units; steel hinges; steel spring clips; steel tension springs; steel crossbar pins; steel flat bar bushing; steel crossbar caps; steel screw (m6 x 22); steel nuts with flange and polyamide insert; steel screw cylinders (6 x 50); top handrail caps; ropes (3 millimeters); wood stringers (left and right 54 inches); rear and front wood boards (22.5 inches to 30 inches); steel claw nuts (6 x 12); rubber gaskets (22.5 inches to 54 inches); staples (14 x 35); moisture resistant plywood boards (22.5 inches x 54 inches to 30 inches x 54 inches); fireproof plywood boards (22.5 inches x 54 inches to 30 inches x 54 inches); carriage bolts (m5 x 55); countersunk chipboard screws (5 x 40); R10 insulation boards (22.5 inches x 54

inches to 30 inches x 54 inches); regular plywood (25 inches x 54 inches to 30 inches x 54 inches); polystyrene filling, R5 insulation boards ((22.5 inches x 54 inches to 30 inches x 54 inches); wood tread; wood ladder stairs; steel M6 claw nuts; steel stair hinge; steel handrails; cardboard boxes (22.5 inches x 54 inches to 30 inches x 54 inches); steel staples (13 x 8); polyethylene film, and paper labels and manual sets.(duty rate ranges from duty-free to 12%). The request indicates that certain materials/components are subject to duties under section 1702(a)(1)(B) of the International Emergency Economic Powers Act (section 1702), section 232 of the Trade Expansion Act of 1962 (section 232) or section 301 of the Trade Act of 1974 (section 301), depending on the country of origin. The applicable section 1702, section 232 and section 301 decisions require subject merchandise to be admitted to FTZs in privileged foreign status (19 CFR 146.41). The request indicates that all its foreign-status components are subject to an antidumping/countervailing duty (AD/CVD) order/investigation if imported from certain countries. The Board's regulations (15 CFR 400.13(c)(2)) require that merchandise subject to AD/CVD orders, or items which would be otherwise subject to suspension of liquidation under AD/CVD procedures if they entered U.S. customs territory, be admitted to the zone in PF status (19 CFR 146.41).

Public comment is invited from interested parties. Submissions shall be addressed to the Board's Executive Secretary and sent to: ftz@trade.gov. The closing period for their receipt is May 20, 2025.

A copy of the notification will be available for public inspection in the "Online FTZ Information System" section of the Board's website.

For further information, contact Kolade Osho at Kolade.Osho@trade.gov.

Dated: April 4, 2025.

Elizabeth Whiteman,
Executive Secretary.

[FR Doc. 2025-06126 Filed 4-9-25; 8:45 am]

BILLING CODE 3510-DS-P

DEPARTMENT OF COMMERCE

International Trade Administration

[A-791-829]

Certain Corrosion-Resistant Steel Products From South Africa: Preliminary Affirmative Determination of Sales at Less Than Fair Value, Postponement of Final Determination, and Extension of Provisional Measures

AGENCY: Enforcement and Compliance, International Trade Administration, Department of Commerce.

SUMMARY: The U.S. Department of Commerce (Commerce) preliminarily determines that Certain Corrosion-Resistant Steel Products (CORE) from South Africa is being, or is likely to be, sold in the United States at less than fair value (LTFV). The period of investigation (POI) is July 1, 2023, through June 30, 2024. Interested parties are invited to comment on this preliminary determination.

DATES: Applicable April 10, 2025.

FOR FURTHER INFORMATION CONTACT: Jacob Saude, AD/CVD Operations, Office VII, Enforcement and Compliance, International Trade Administration, U.S. Department of Commerce, 1401 Constitution Avenue NW, Washington, DC 20230; telephone: (202) 482-0981.

SUPPLEMENTARY INFORMATION:

Background

This preliminary determination is made in accordance with section 733(b) of the Tariff Act of 1930, as amended (the Act). Commerce published the notice of initiation of this investigation on October 2, 2024.¹ On January 28, 2025, Commerce postponed the preliminary determination of this investigation until April 3, 2025.² On March 24, 2025, Commerce preliminarily determined that critical circumstances do not exist.³ For a

¹ See *Certain Corrosion-Resistant Steel Products from Australia, Brazil, Canada, Mexico, the Netherlands, South Africa, Taiwan, the Republic of Türkiye, the United Arab Emirates, and the Socialist Republic of Vietnam: Initiation of Less-Than-Fair-Value Investigations*, 89 FR 80196 (October 2, 2024) (*Initiation Notice*).

² See *Certain Corrosion-Resistant Steel Products from Australia, Brazil, Canada, Mexico, the Netherlands, South Africa, Taiwan, the Republic of Türkiye, the United Arab Emirates, and the Socialist Republic of Vietnam: Postponement of Preliminary Determinations in the Less-Than-Fair-Value Investigations*, 90 FR 8260 (January 28, 2025).

³ See *Certain Corrosion-Resistant Steel Products from the United Arab Emirates and South Africa: Preliminary Affirmative Determination, In Part, of Critical Circumstances*, 90 FR 14599 (April 3, 2025), and accompanying Decision Memorandum (Preliminary Critical Circumstances Decision Memorandum).

complete description of the events that followed the initiation of this investigation, see the Preliminary Decision Memorandum.⁴ A list of topics included in the Preliminary Decision Memorandum is included as Appendix II to this notice. The Preliminary Decision Memorandum is a public document and is on file electronically via Enforcement and Compliance's Antidumping and Countervailing Duty Centralized Electronic Service System (ACCESS). ACCESS is available to registered users at <https://access.trade.gov>. In addition, a complete version of the Preliminary Decision Memorandum can be accessed directly at <https://access.trade.gov/public/FRNoticesListLayout.aspx>.

Scope of the Investigation

The product covered by this investigation is CORE from South Africa. For a complete description of the scope of this investigation, see Appendix I.

Scope Comments

In accordance with the *Preamble* to Commerce's regulations,⁵ in the *Initiation Notice*, Commerce set aside a period of time for parties to raise issues regarding product coverage (*i.e.*, scope).⁶ Certain interested parties commented on the scope of the investigation as it appeared in the *Initiation Notice*. For a summary of the product coverage comments and rebuttal responses submitted to the record for this investigation and accompanying discussion and analysis of all comments timely received, see the Preliminary Scope Decision Memorandum.⁷ Commerce is not preliminarily modifying the scope language as it appeared in the *Initiation Notice*. See the scope in Appendix I to this notice. In the Preliminary Scope Decision Memorandum, Commerce established the deadline for parties to submit scope case and rebuttal briefs.⁸

Methodology

Commerce is conducting this investigation in accordance with section 731 of the Act. Constructed export

⁴ See Memorandum, "Decision Memorandum for the Preliminary Determination in the Less-Than-Fair-Value Investigation of Certain Corrosion-Resistant Steel Products from South Africa," dated concurrently with, and hereby adopted by, this notice (Preliminary Decision Memorandum).

⁵ See *Antidumping Duties; Countervailing Duties, Final Rule*, 62 FR 27296, 27323 (May 19, 1997) (*Preamble*).

⁶ See *Initiation Notice*, 89 FR at 80197.

⁷ See Memorandum, "Preliminary Scope Decision Memorandum," dated concurrently with this notice (Preliminary Scope Decision Memorandum).

⁸ *Id.*

prices have been calculated in accordance with section 772(b) of the Act. Normal value is calculated in accordance with section 773 of the Act. For a full description of the methodology underlying the preliminary determination, see the Preliminary Decision Memorandum.

All-Others Rate

Sections 733(d)(1)(A)(ii) and 735(c)(5)(A) of the Act provide that in the preliminary determination Commerce shall determine an estimated all-others rate for all exporters and producers not individually examined. This rate shall be an amount equal to the weighted average of the estimated weighted-average dumping margins established for exporters and producers individually investigated, excluding any zero and *de minimis* margins, and any margins determined entirely under section 776 of the Act.

Commerce calculated an individual estimated weighted-average dumping margin for Duferco Steel Processing PTY Ltd. (DSP), the only individually examined exporter/producer in this investigation. Because the only individually calculated dumping margin is not zero, *de minimis*, or based entirely on facts otherwise available, the estimated weighted-average dumping margin calculated for DSP is the margin assigned to all other producers and exporters, pursuant to section 735(c)(5)(A) of the Act.

Preliminary Determination

Commerce preliminarily determines that the following estimated weighted-average dumping margins exist:

Exporter/producer	Weighted-average dumping margin (percent)
Duferco Steel Processing PTY Ltd	17.90
All Others	17.90

Suspension of Liquidation

In accordance with section 733(d)(2) of the Act, Commerce will direct U.S. Customs and Border Protection (CBP) to suspend liquidation of entries of subject merchandise, as described in Appendix I, entered, or withdrawn from warehouse, for consumption on or after the date of publication of this notice in the **Federal Register**. Further, pursuant to section 733(d)(1)(B) of the Act and 19 CFR 351.205(d), Commerce will instruct CBP to require a cash deposit equal to the estimated weighted-average dumping margin or the estimated all-others rate, as follows: (1) The cash

deposit rate for the respondents listed above will be equal to the company-specific estimated weighted-average dumping margins determined in this preliminary determination; (2) if the exporter is not a respondent identified above, but the producer is, then the cash deposit rate will be equal to the company-specific estimated weighted-average dumping margin established for that producer of the subject merchandise; and (3) the cash deposit rate for all other producers and exporters will be equal to the all-others estimated weighted-average dumping margin. These suspension of liquidation instructions will remain in effect until further notice.

Disclosure

Commerce intends to disclose its calculations and analysis performed to interested parties in this preliminary determination within five days of any public announcement or, if there is no public announcement, within five days of the date of publication of this notice in accordance with 19 CFR 351.224(b).

Consistent with 19 CFR 351.224(e), Commerce will analyze and, if appropriate, correct any timely allegations of significant ministerial errors by amending the preliminary determination. However, consistent with 19 CFR 351.224(d), Commerce will not consider incomplete allegations that do not address the significance standard under 19 CFR 351.224(g) following the preliminary determination. Instead, Commerce will address such allegations in the final determination together with issues raised in the case briefs or other written comments.

Verification

As provided in section 782(i)(1) of the Act, Commerce intends to verify the information relied upon in making its final determination.

Public Comment

Case briefs or other written comments, excluding scope comments, may be submitted to the Assistant Secretary for Enforcement and Compliance no later than seven days after the date on which the last verification report is issued in this investigation.⁹ Rebuttal briefs, limited to issues raised in the case briefs, may be filed not later than five days after the date for filing case briefs.¹⁰ Interested

parties who submit case briefs or rebuttal briefs in this proceeding must submit: (1) a table of contents listing each issue; and (2) a table of authorities.¹¹

As provided under 19 CFR 351.309(c)(2) and (d)(2), in prior proceedings we have encouraged interested parties to provide an executive summary of their brief that should be limited to five pages total, including footnotes. In this investigation, we instead request that interested parties provide at the beginning of their briefs a public, executive summary for each issue raised in their briefs.¹² Further, we request that interested parties limit their executive summary of each issue to no more than 450 words, not including citations. We intend to use the executive summaries as the basis of the comment summaries included in the issues and decision memorandum that will accompany the final determination in this investigation. We request that interested parties include footnotes for relevant citations in the executive summary of each issue. Note that Commerce has amended certain of its requirements pertaining to the service of documents in 19 CFR 351.303(f).¹³

Pursuant to 19 CFR 351.310(c), interested parties who wish to request a hearing, limited to issues raised in the case and rebuttal briefs, must submit a written request to the Assistant Secretary for Enforcement and Compliance, U.S. Department of Commerce, within 30 days after the date of publication of this notice.

Requests should contain: (1) the party's name, address, and telephone number; (2) the number of participants and whether any participant is a foreign national; and (3) a list of the issues to be discussed. If a request for a hearing is made, Commerce intends to hold the hearing at a date and time to be determined. Parties should confirm by telephone the date, time, and location of the hearing two days before the scheduled date.

Postponement of Final Determination and Extension of Provisional Measures

Section 735(a)(2) of the Act provides that a final determination may be postponed until not later than 135 days after the date of the publication of the preliminary determination if, in the event of an affirmative preliminary determination, a request for such

⁹ See 19 CFR 351.309(c)(1)(i); see also 19 CFR 351.303 (for general filing requirements).

¹⁰ See 19 CFR 351.309(d); see also *Administrative Protective Order, Service, and Other Procedures in Antidumping and Countervailing Duty Proceedings*, 88 FR 67069, 67077 (September 29, 2023) (*APO and Service Final Rule*).

¹¹ See 19 351.309(c)(2) and (d)(2).

¹² We use the term "issue" here to describe an argument that Commerce would normally address in a comment of the Issues and Decision Memorandum.

¹³ See *AP0 and Service Final Rule*.

postponement is made by exporters who account for a significant proportion of exports of the subject merchandise, or in the event of a negative preliminary determination, a request for such postponement is made by the petitioner. Section 351.210(e)(2) of Commerce's regulations requires that a request by exporters for postponement of the final determination be accompanied by a request for extension of provisional measures from a four-month period to a period not more than six months in duration.

On March 31, 2025, pursuant to 19 CFR 351.210(e), DSP requested that Commerce postpone the final determination and that provisional measures be extended to a period not to exceed six months.¹⁴ In accordance with section 735(a)(2)(A) of the Act and 19 CFR 351.210(b)(2)(ii), because: (1) the preliminary determination is affirmative; (2) the requesting exporter accounts for a significant proportion of exports of the subject merchandise; and (3) no compelling reasons for denial exist, Commerce is postponing the final determination and extending the provisional measures from a four-month period to a period not greater than six months. Accordingly, Commerce will make its final determination no later than 135 days after the date of publication of this preliminary determination.

U.S. International Trade Commission Notification

In accordance with section 733(f) of the Act, Commerce will notify the U.S. International Trade Commission (ITC) of its preliminary determination. If the final determination is affirmative, the ITC will determine before the later of 120 days after the date of this preliminary determination or 45 days after the final determination whether these imports are materially injuring, or threaten material injury to, the U.S. industry.

Notification to Interested Parties

This determination is issued and published in accordance with sections 733(f) and 777(i)(1) of the Act and 19 CFR 351.205(c).

Dated: April 3, 2025.

Christopher Abbott,

Deputy Assistant Secretary for Policy and Negotiations, performing the Non-exclusive Functions and Duties of the Assistant Secretary for Enforcement and Compliance.

Appendix I

Scope of the Investigation

The products covered by this investigation are certain flat-rolled steel products, either clad, plated, or coated with corrosion-resistant metals such as zinc, aluminum, or zinc-, aluminum-, nickel- or iron-based alloys, whether or not corrugated or painted, varnished, laminated, or coated with plastics or other non-metallic substances in addition to the metallic coating. The products covered include coils that have a width of 12.7 mm or greater, regardless of form of coil (*e.g.*, in successively superimposed layers, spirally oscillating, *etc.*). The products covered also include products not in coils (*e.g.*, in straight lengths) of a thickness less than 4.75 mm and a width that is 12.7 mm or greater and that measures at least 10 times the thickness. The products covered also include products not in coils (*e.g.*, in straight lengths) of a thickness of 4.75 mm or more and a width exceeding 150 mm and measuring at least twice the thickness. The products described above may be rectangular, square, circular, or other shape and include products of either rectangular or non-rectangular cross-section where such cross-section is achieved subsequent to the rolling process, *i.e.*, products which have been "worked after rolling" (*e.g.*, products which have been beveled or rounded at the edges).

For purposes of the width and thickness requirements referenced above:

(1) Where the nominal and actual measurements vary, a product is within the scope if application of either the nominal or actual measurement would place it within the scope based on the definitions set forth above, and

(2) where the width and thickness vary for a specific product (*e.g.*, the thickness of certain products with non-rectangular cross-section, the width of certain products with non-rectangular shape, *etc.*), the measurement at its greatest width or thickness applies.

Steel products included in the scope of this investigation are products in which: (1) iron predominates, by weight, over each of the other contained elements; and (2) the carbon content is 2 percent or less, by weight.

Subject merchandise also includes corrosion-resistant steel that has been further processed in a third country, including but not limited to annealing, tempering, painting, varnishing, trimming, cutting, punching and/or slitting or any other processing that would not otherwise remove the merchandise from the scope of the investigations if performed in the country of manufacture of the in-scope corrosion resistant steel.

All products that meet the written physical description are within the scope of this investigation unless specifically excluded. The following products are outside of and/or specifically excluded from the scope of this investigation:

- Flat-rolled steel products either plated or coated with tin, lead, chromium, chromium oxides, both tin and lead ("terne plate") or both chromium and chromium oxides ("tin free steel"), whether or not painted, varnished or coated with plastics or other non-metallic substances in addition to the metallic coating;

- Clad products in straight lengths of 4.7625 mm or more in composite thickness and of a width which exceeds 150 mm and measures at least twice the thickness;

- Certain clad stainless flat-rolled products, which are three-layered corrosion-resistant carbon steel flat-rolled products less than 4.75 mm in composite thickness that consist of a carbon steel flat-rolled product clad on both sides with stainless steel in a 20%–60%–20% ratio; and

Also excluded from the scope of the antidumping duty investigation on corrosion resistant steel from Taiwan are any products covered by the existing antidumping duty order on corrosion-resistant steel from Taiwan. *See Certain Corrosion-Resistant Steel Products from India, Italy, the People's Republic of China, the Republic of Korea and Taiwan: Amended Final Affirmative Antidumping Determination for India and Taiwan, and Antidumping Duty Orders*, 81 FR 48390 (July 25, 2016); *Corrosion-Resistant Steel Products from Taiwan: Notice of Third Amended Final Determination of Sales at Less Than Fair Value Pursuant to Court Decision and Partial Exclusion from Antidumping Duty Order*, 88 FR 58245 (August 25, 2023).

Also excluded from the scope of the antidumping duty investigation on corrosion-resistant steel from the United Arab Emirates and the antidumping duty and countervailing duty investigations on corrosion-resistant steel from the Socialist Republic of Vietnam are any products covered by the existing antidumping and countervailing duty orders on corrosion-resistant steel from the People's Republic of China and the Republic of Korea and the antidumping duty order on corrosion-resistant steel from Taiwan. *See Certain Corrosion-Resistant Steel Products from India, Italy, the People's Republic of China, the Republic of Korea and Taiwan: Amended Final Affirmative Antidumping Determination for India and Taiwan, and Antidumping Duty Orders*, 81 FR 48390 (July 25, 2016); *see also Certain Corrosion-Resistant Steel Products from India, Italy, Republic of Korea and the People's Republic of China: Countervailing Duty Order*, 81 FR 48387 (July 25, 2016). This exclusion does not apply to imports of corrosion-resistant steel that are entered, or withdrawn from warehouse, for consumption in the United States for which the relevant importer and exporter certifications have been completed and maintained and all other applicable certification requirements have been met such that the entry is entered into the United States as not subject to the antidumping and countervailing duty orders on corrosion-resistant steel from the People's Republic of China, the antidumping and countervailing duty orders on corrosion-resistant steel from the Republic of Korea, or the antidumping duty order on corrosion-resistant steel from Taiwan.

¹⁴ See DSP's Letter, "Dufenco Steel Processing PTY Ltd.'s Request to Postpone Final Determination," dated March 31, 2025.

The products subject to the investigation are currently classified in the Harmonized Tariff Schedule of the United States (HTSUS) under item numbers: 7210.30.0030, 7210.30.0060, 7210.41.0000, 7210.49.0030, 7210.49.0040, 7210.49.0045, 7210.49.0091, 7210.49.0095, 7210.61.0000, 7210.69.0000, 7210.70.6030, 7210.70.6060, 7210.70.6090, 7210.90.6000, 7210.90.9000, 7212.20.0000, 7212.30.1030, 7212.30.1090, 7212.30.3000, 7212.30.5000, 7212.40.1000, 7212.40.5000, 7212.50.0000, 7212.60.0000, 7225.91.0000, 7225.92.0000, 7226.99.0110, and 7226.99.0130.

The products subject to the investigation may also enter under the following HTSUS item numbers: 7210.90.1000, 7215.90.1000, 7215.90.3000, 7215.90.5000, 7217.20.1500, 7217.30.1530, 7217.30.1560, 7217.90.1000, 7217.90.5030, 7217.90.5060, 7217.90.5090, 7225.99.0090, 7226.99.0180, 7228.60.6000, 7228.60.8000, and 7229.90.1000.

The HTSUS subheadings above are provided for convenience and customs purposes only. The written description of the scope of the investigation is dispositive.

Appendix II

List of Topics Discussed in the Preliminary Decision Memorandum

- I. Summary
- II. Background
- III. Period of Investigation
- IV. Scope Comments
- V. Preliminary Determination of Critical Circumstances
- VI. Affiliation
- VII. Discussion of the Methodology
- VIII. Currency Conversion
- IX. Recommendation

[FR Doc. 2025-06138 Filed 4-9-25; 8:45 am]

BILLING CODE 3510-DS-P

DEPARTMENT OF COMMERCE

International Trade Administration

Subsidy Programs Provided by Countries Exporting Softwood Lumber and Softwood Lumber Products to the United States; Request for Comment

AGENCY: Enforcement and Compliance, International Trade Administration, Department of Commerce.

SUMMARY: The U.S. Department of Commerce (Commerce) seeks public comment on any subsidies, including stumpage subsidies, provided by certain countries exporting softwood lumber or softwood lumber products to the United States during the period July 1, 2024 through December 31, 2024.

DATES: Comments must be submitted by May 12, 2025.

ADDRESSES: All comments must be submitted through the Federal eRulemaking Portal at <https://www.regulations.gov>, Docket No. ITA-2025-0002. The materials in the docket will not be edited to remove identifying

or contact information, and Commerce cautions against including any information in an electronic submission that the submitter does not want publicly disclosed. Attachments to electronic comments will be accepted in Microsoft Word, Excel, or Adobe PDF formats only.

All comments should be addressed to Christopher Abbott, Deputy Assistant Secretary for Policy and Negotiations, performing the non-exclusive functions and duties of the Assistant Secretary for Enforcement and Compliance, at the U.S. Department of Commerce, 1401 Constitution Avenue NW, Washington, DC 20230.

FOR FURTHER INFORMATION CONTACT:

Kristen Johnson, AD/CVD Operations, Office III, Enforcement and Compliance, International Trade Administration, U.S. Department of Commerce, 1401 Constitution Avenue NW, Washington, DC 20230; telephone: (202) 482-4793.

SUPPLEMENTARY INFORMATION:

Background

Pursuant to section 805 of title VIII of the Tariff Act of 1930 (the Softwood Lumber Act of 2008), the Secretary of Commerce is mandated to submit to the appropriate Congressional committees a report every 180 days on any subsidy provided by countries exporting softwood lumber or softwood lumber products to the United States, including stumpage subsidies. Commerce submitted its last subsidy report to the Congress on December 20, 2024.

Request for Comments

Given the large number of countries that export softwood lumber and softwood lumber products to the United States, we are soliciting public comment only on subsidies provided by countries which had exports accounting for at least one percent of total U.S. imports of softwood lumber by quantity, as classified under Harmonized Tariff Schedule of the United States (HTSUS) subheadings 4407.1100, 4407.1200, 4407.1300, 4407.1400, and 4407.1900, during the period July 1, 2024 through December 31, 2024. Official U.S. import data, published by the United States International Trade Commission's DataWeb, indicate that four countries (Brazil, Canada, Germany, and Sweden) exported softwood lumber to the United States during that time period in amounts sufficient to account for at least one percent of U.S. imports of softwood lumber products. We intend to rely on similar six-month periods to identify the countries subject to future reports on softwood lumber subsidies. For example, we intend to rely on U.S.

imports of softwood lumber and softwood lumber products during the period January 1, 2025, through June 30, 2025, to select the countries subject for the next report.

Under U.S. trade law, a subsidy exists where an authority: (i) provides a financial contribution; (ii) provides any form of income or price support within the meaning of Article XVI of the General Agreements on Tariffs and Trade 1994; or (iii) makes a payment to a funding mechanism to provide a financial contribution to a person, or entrusts or directs a private entity to make a financial contribution, if providing the contribution would normally be vested in the government and the practice does not differ in substance from practices normally followed by governments, and a benefit is thereby conferred.¹

Parties should include in their comments: (1) the country which provided the subsidy; (2) the name of the subsidy program; (3) a brief description (no more than 3-4 sentences) of the subsidy program; and (4) the government body or authority that provided the subsidy.

Dated: April 7, 2025.

Christopher Abbott,

Deputy Assistant Secretary for Policy and Negotiations, performing the non-exclusive functions and duties of the Assistant Secretary for Enforcement and Compliance.

[FR Doc. 2025-06146 Filed 4-9-25; 8:45 am]

BILLING CODE 3510-DS-P

DEPARTMENT OF COMMERCE

International Trade Administration

[A-351-862]

Certain Corrosion-Resistant Steel Products From Brazil: Preliminary Affirmative Determination of Sales at Less Than Fair Value, Postponement of Final Determination, and Extension of Provisional Measures

AGENCY: Enforcement and Compliance, International Trade Administration, Department of Commerce.

SUMMARY: The U.S. Department of Commerce (Commerce) preliminarily determines that certain corrosion-resistant steel products (CORE) from Brazil are being, or are likely to be, sold in the United States at less than fair value (LTFV). The period of investigation is July 1, 2023, through June 30, 2024. Interested parties are invited to comment on this preliminary determination.

¹ See section 771(5)(B) of the Tariff Act of 1930, as amended.

DATES: Applicable April 10, 2025.

FOR FURTHER INFORMATION CONTACT:

Carter Sherwin or Nathan Araya, AD/CVD Operations, Office II, Enforcement and Compliance, International Trade Administration, U.S. Department of Commerce, 1401 Constitution Avenue NW, Washington, DC 20230; telephone: (202) 482-4260 or (202) 482-3401, respectively.

SUPPLEMENTARY INFORMATION:

Background

This preliminary determination is made in accordance with section 733(b) of the Tariff Act of 1930, as amended (the Act). Commerce published the notice of initiation of this investigation on October 2, 2024.¹ On January 28, 2025, Commerce postponed the preliminary determination of this investigation until April 3, 2025.² For a complete description of the events that followed the initiation of this investigation, see the Preliminary Decision Memorandum.³ A list of topics included in the Preliminary Decision Memorandum is included as Appendix II to this notice. The Preliminary Decision Memorandum is a public document and is on file electronically via Enforcement and Compliance's Antidumping and Countervailing Duty Centralized Electronic Service System (ACCESS). ACCESS is available to registered users at <https://access.trade.gov>. In addition, a complete version of the Preliminary Decision Memorandum can be accessed directly at <https://access.trade.gov/public/FRNoticesListLayout.aspx>.

Scope of the Investigation

The product covered by this investigation is CORE from Brazil. For a complete description of the scope of this investigation, see Appendix I.

¹ See *Certain Corrosion-Resistant Steel Products from Australia, Brazil, Canada, Mexico, the Netherlands, South Africa, Taiwan, Turkey, the United Arab Emirates, and the Socialist Republic of Vietnam: Initiation of Less-Than-Fair-Value Investigations*, 89 FR 80196 (October 2, 2024) (*Initiation Notice*).

² See *Certain Corrosion-Resistant Steel Products from Australia, Brazil, Canada, Mexico, the Netherlands, South Africa, Taiwan, the Republic of Türkiye, the United Arab Emirates, and the Socialist Republic of Vietnam: Postponement of Preliminary Determinations of Antidumping Duty Investigations*, 90 FR 8260 (January 28, 2025).

³ See Memorandum, "Decision Memorandum for the Preliminary Determination in the Less-Than-Fair-Value Investigation of Certain Corrosion-Resistant Steel Products from Brazil," dated concurrently with, and hereby adopted by, this notice (Preliminary Decision Memorandum).

Scope Comments

In accordance with the *Preamble* to Commerce's regulations,⁴ in the *Initiation Notice*, Commerce set aside a period of time for parties to raise issues regarding product coverage (*i.e.*, scope).⁵ Certain interested parties commented on the scope of the investigation as it appeared in the *Initiation Notice*. For a summary of the product coverage comments and rebuttal responses submitted to the record for this investigation and accompanying discussion and analysis of all comments timely received, see the Preliminary Scope Decision Memorandum.⁶ Commerce is not preliminarily modifying the scope language as it appeared in the *Initiation Notice*. See the scope in Appendix I to this notice. In the Preliminary Scope Decision Memorandum, Commerce established the deadline for parties to submit scope case and rebuttal briefs.⁷

Methodology

Commerce is conducting this investigation in accordance with section 731 of the Act. Commerce has calculated export prices in accordance with section 772(a) of the Act. Constructed export prices have been calculated in accordance with section 772(b) of the Act. Normal value is calculated in accordance with section 773 of the Act. For a full description of the methodology underlying the preliminary determination, see the Preliminary Decision Memorandum.

All-Others Rate

Sections 733(d)(1)(ii) and 735(c)(5)(A) of the Act provide that, in the preliminary determination, Commerce shall determine an estimated all-others rate for all exporters and producers not individually examined. This rate shall be an amount equal to the weighted average of the estimated weighted-average dumping margins established for exporters and producers individually investigated, excluding rates that are zero, *de minimis*, or determined entirely under section 776 of the Act.

Commerce has preliminarily calculated estimated weighted-average dumping margins for Companhia Siderurgica Nacional (CSN) and Usiminas Siderurgicas de Minas Gerais S.A. (Usiminas) that are not zero, *de*

⁴ See *Antidumping Duties; Countervailing Duties, Final Rule*, 62 FR 27296, 27323 (May 19, 1997).

⁵ See *Initiation Notice*.

⁶ See Memorandum, "Preliminary Scope Decision Memorandum," dated concurrently with this notice (Preliminary Scope Decision Memorandum).

⁷ *Id.*

minimis, or based entirely on facts otherwise available. Commerce calculated the all-others rate using a weighted average of the estimated weighted-average dumping margins calculated for the examined respondents using each company's publicly-ranged values for the merchandise under consideration.⁸

Preliminary Determination

Commerce preliminarily determines that the following estimated weighted-average dumping margins exist:

Exporter/producer	Weighted-average dumping margin (percent)
Companhia Siderurgica Nacional; Companhia Metalurgica Prada ⁹	¹⁰ 137.76
Usiminas Siderurgicas de Minas Gerais S.A.; Unigal Ltda.; Soluções em Aço Usiminas ¹¹	¹² 31.53
All Others	118.63

Suspension of Liquidation

In accordance with section 733(d)(2) of the Act, Commerce will direct U.S. Customs and Border Protection (CBP) to suspend liquidation of entries of subject

⁸ With two respondents under examination, Commerce normally calculates: (A) a weighted-average of the estimated weighted-average dumping margins calculated for the examined respondents; (B) a simple average of the estimated weighted-average dumping margins calculated for the examined respondents using each company's publicly-ranged U.S. sales values for the merchandise under consideration. Commerce then compares (B) and (C) to (A) and selects the rate closest to (A) as the most appropriate rate for all other producers and exporters. See, *e.g.*, *Ball Bearings and Parts Thereof from France, Germany, Italy, Japan, and the United Kingdom: Final Results of Antidumping Duty Administrative Reviews, Final Results of Changed-Circumstances Review, and Revocation of an Order in Part*, 75 FR 53661, 53662 (September 1, 2010), and accompanying Issues and Decision Memorandum at Comment 1. As complete publicly ranged sales data were available, Commerce based the all-others rate on the publicly ranged sales data of the mandatory respondents. For a complete analysis of the data, see the All-Others Rate Calculation Memorandum.

⁹ Commerce preliminarily determines that CSN and Companhia Metalurgica Prada are a single entity. See Preliminary Decision Memorandum.

¹⁰ CSN preliminarily received a preliminary net subsidy rate of 1.76 percent in the companion CVD investigation; however, none of the countervailable subsidies were export related. Therefore, no CVD offset/adjustment is being made to the cash deposit rate.

¹¹ Commerce preliminarily determines that Usiminas, Unigal Ltda., and Soluções em Aço Usiminas are a single entity. See Preliminary Decision Memorandum.

¹² Usiminas preliminarily received a *de minimis* rate of 0.33 percent in the companion CVD investigation. As a result, no CVD offset/adjustment is being made to the cash deposit rate.

merchandise, as described in Appendix I, entered, or withdrawn from warehouse, for consumption on or after the date of publication of this notice in the **Federal Register**. Further, pursuant to section 733(d)(1)(B) of the Act and 19 CFR 351.205(d), Commerce will instruct CBP to require a cash deposit equal to the estimated weighted-average dumping margin or the estimated all-others rate, as follows: (1) The cash deposit rate for the respondents listed above will be equal to the company-specific estimated weighted-average dumping margins determined in this preliminary determination; (2) if the exporter is not a respondent identified above, but the producer is, then the cash deposit rate will be equal to the company-specific estimated weighted-average dumping margin established for that producer of the subject merchandise and (3) the cash deposit rate for all other producers and exporters will be equal to the all-others estimated weighted-average dumping margin.

Commerce normally adjusts cash deposits for estimated antidumping duties by the amount of export subsidies countervailed in a companion countervailing duty (CVD) proceeding, when CVD provisional measures are in effect. As stated above, because Commerce did not find countervailable export related subsidies for CSN and Usiminas received a *de minimis* subsidy rate in the companion CVD investigation, Commerce has not offset the estimated weighted-average dumping margin in this preliminary determination.¹³ Additionally, because the all-others rate is calculated based on the rates for CSN and Usiminas, the all-others weighted-average dumping margin will remain at 118.82 percent.¹⁴

These suspension of liquidation instructions will remain in effect until further notice.

Disclosure

Commerce intends to disclose its calculations and analysis performed to interested parties in this preliminary determination within five days of any public announcement or, if there is no public announcement, within five days of the date of publication of this notice in accordance with 19 CFR 351.224(b).

Consistent with 19 CFR 351.224(e), Commerce will analyze and, if appropriate, correct any timely allegations of significant ministerial errors by amending the preliminary determination. However, consistent with 19 CFR 351.224(d), Commerce will

not consider incomplete allegations that do not address the significance standard under 19 CFR 351.224(g) following the preliminary determination. Instead, Commerce will address such allegations in the final determination together with issues raised in the case briefs or other written comments.

Verification

As provided in section 782(i)(1) of the Act, Commerce intends to verify the information relied upon in making its final determination.

Public Comment

Case briefs or other written comments, excluding scope comments, may be submitted to the Assistant Secretary for Enforcement and Compliance no later than seven days after the date on which the last verification report is issued in this investigation.¹⁵ Rebuttal briefs, limited to issues raised in case briefs, may be filed not later than five days after the date for filing case briefs.¹⁶ Interested parties who submit case briefs or rebuttal briefs in this proceeding must submit: (1) a table of contents listing each issue; and (2) a table of authorities.¹⁷

As provided under 19 CFR 351.309(c)(2) and (d)(2), in prior proceedings we have encouraged interested parties to provide an executive summary of their briefs that should be limited to five pages total, including footnotes. In this investigation, we instead request that interested parties provide at the beginning of their briefs a public, executive summary for each issue raised in their briefs. Further, we request that interested parties limit their executive summary of each issue to no more than 450 words, not including citations. We intend to use the public executive summaries as the basis of the comment summaries included in the issues and decision memorandum that will accompany the final determination in this investigation. We request that interested parties include footnotes for relevant citations in the public executive summary of each issue. Note that Commerce has amended certain of its requirements pertaining to the service of documents in 19 CFR 351.303(f).¹⁸

¹⁵ See 19 CFR 351.309(c)(1)(i); see also 19 CFR 351.303 (for general filing requirements).

¹⁶ See 19 CFR 351.309(d); see also *Administrative Protective Order, Service, and Other Procedures in Antidumping and Countervailing Duty Proceedings*, 88 FR 67069, 67077 (September 29, 2023) (*APO and Service Final Rule*).

¹⁷ See 19 CFR 351.309(c)(2) and (d)(2).

¹⁸ See *APO and Service Final Rule*.

Pursuant to 19 CFR 351.310(c), interested parties who wish to request a hearing, limited to issues raised in the case and rebuttal briefs, must submit a written request to the Assistant Secretary for Enforcement and Compliance, U.S. Department of Commerce, within 30 days after the date of publication of this notice. Requests should contain: (1) the party's name, address, and telephone number; (2) the number of participants and whether any participant is a foreign national; and (3) a list of the issues to be discussed. If a request for a hearing is made, Commerce intends to hold the hearing at a date and time to be determined. Parties should confirm by telephone the date, time, and location of the hearing two days before the scheduled date.

Postponement of Final Determination and Extension of Provisional Measures

Section 735(a)(2) of the Act provides that a final determination may be postponed until not later than 135 days after the date of the publication of the preliminary determination if, in the event of an affirmative preliminary determination, a request for such postponement is made by exporters who account for a significant proportion of exports of the subject merchandise, or in the event of a negative preliminary determination, a request for such postponement is made by the petitioner. Section 351.210(e)(2) of Commerce's regulations requires that a request by exporters for postponement of the final determination be accompanied by a request for extension of provisional measures from a four-month period to a period not more than six months in duration.

On March 31 and April 1, 2025, pursuant to 19 CFR 351.210(e), Steel Dynamics, Inc., Nucor Corporation, Wheeling-Nippon Steel, Inc., and the United Steel, Paper and Forestry, Rubber, Manufacturing, Energy, Allied Industrial and Service Workers International Union, AFL-CIO, CLC (the petitioners), and CSN, respectively, requested that Commerce postpone the final determination and that provisional measures be extended to a period not to exceed six months.¹⁹ In accordance with section 735(a)(2)(A) of the Act and 19 CFR 351.210(b)(2)(ii), because: (1) the preliminary determination is affirmative; (2) the requesting exporter accounts for a significant proportion of exports of the subject merchandise; and (3) no compelling reasons for denial

¹⁹ See Petitioners' Letter, "Request for Postponement of Final Determination," dated March 31, 2025; see also CSN's Letter, "Request to Postpone the Final Determination," dated April 1, 2025.

¹³ See Preliminary Decision Memorandum.

¹⁴ *Id.*

exist, Commerce is postponing the final determination and extending the provisional measures from a four-month period to a period not greater than six months. Accordingly, Commerce will make its final determination no later than 135 days after the date of publication of this preliminary determination.

U.S. International Trade Commission (ITC) Notification

In accordance with section 733(f) of the Act, Commerce will notify the ITC of its preliminary determination. If the final determination is affirmative, the ITC will determine before the later of 120 days after the date of this preliminary determination or 45 days will determine before the later of 120 days after the date of this preliminary determination or 45 days after the final determination whether these imports are materially injuring, or threaten material injury to, the U.S. industry.

Notification to Interested Parties

This determination is issued and published in accordance with sections 733(f) and 777(i)(1) of the Act, and 19 CFR 351.205(c).

Dated: April 3, 2025.

Christopher Abbott,

Deputy Assistant Secretary for Policy and Negotiations, performing the non-exclusive functions and duties of the Assistant Secretary for Enforcement and Compliance.

Appendix I

Scope of the Investigation

The products covered by this investigation are certain flat-rolled steel products, either clad, plated, or coated with corrosion-resistant metals such as zinc, aluminum, or zinc-, aluminum-, nickel- or iron-based alloys, whether or not corrugated or painted, varnished, laminated, or coated with plastics or other non-metallic substances in addition to the metallic coating. The products covered include coils that have a width of 12.7 mm or greater, regardless of form of coil (*e.g.*, in successively superimposed layers, spirally oscillating, *etc.*). The products covered also include products not in coils (*e.g.*, in straight lengths) of a thickness less than 4.75 mm and a width that is 12.7 mm or greater and that measures at least 10 times the thickness. The products covered also include products not in coils (*e.g.*, in straight lengths) of a thickness of 4.75 mm or more and a width exceeding 150 mm and measuring at least twice the thickness. The products described above may be rectangular, square, circular, or other shape and include products of either rectangular or non-rectangular cross-section where such cross-section is achieved subsequent to the rolling process, *i.e.*, products which have been “worked after rolling” (*e.g.*, products which have been beveled or rounded at the edges).

For purposes of the width and thickness requirements referenced above:

(1) Where the nominal and actual measurements vary, a product is within the scope if application of either the nominal or actual measurement would place it within the scope based on the definitions set forth above, and

(2) where the width and thickness vary for a specific product (*e.g.*, the thickness of certain products with non-rectangular cross-section, the width of certain products with non-rectangular shape, *etc.*), the measurement at its greatest width or thickness applies.

Steel products included in the scope of this investigation are products in which:

(1) iron predominates, by weight, over each of the other contained elements; and (2) the carbon content is 2 percent or less, by weight.

Subject merchandise also includes corrosion-resistant steel that has been further processed in a third country, including but not limited to annealing, tempering, painting, varnishing, trimming, cutting, punching and/or slitting or any other processing that would not otherwise remove the merchandise from the scope of the investigation if performed in the country of manufacture of the in-scope corrosion resistant steel.

All products that meet the written physical description are within the scope of this investigation unless specifically excluded. The following products are outside of and/or specifically excluded from the scope of this investigation:

- Flat-rolled steel products either plated or coated with tin, lead, chromium, chromium oxides, both tin and lead (“terne plate”) or both chromium and chromium oxides (“tin free steel”), whether or not painted, varnished or coated with plastics or other non-metallic substances in addition to the metallic coating;
- Clad products in straight lengths of 4.7625 mm or more in composite thickness and of a width which exceeds 150 mm and measures at least twice the thickness;
- Certain clad stainless flat-rolled products, which are three-layered corrosion-resistant carbon steel flat-rolled products less than 4.75 mm in composite thickness that consist of a carbon steel flat-rolled product clad on both sides with stainless steel in a 20%–60%–20% ratio;

Also excluded from the scope of the antidumping duty investigations on corrosion resistant steel from Taiwan are any products covered by the existing antidumping duty order on corrosion resistant steel from Taiwan. *See Certain Corrosion-Resistant Steel Products from India, Italy, the People’s Republic of China, the Republic of Korea and Taiwan: Amended Final Affirmative Antidumping Determination for India and Taiwan, and Antidumping Duty Orders*, 81 FR 48390 (July 25, 2016); *Corrosion-Resistant Steel Products from Taiwan: Notice of Third Amended Final Determination of Sales at Less Than Fair Value Pursuant to Court Decision and Partial Exclusion from Antidumping Duty Order*, 88 FR 58245 (August 25, 2023).

Also excluded from the scope of the antidumping duty investigation on corrosion-resistant steel from the United Arab Emirates and the antidumping duty and countervailing duty investigations on corrosion-resistant

steel from the Socialist Republic of Vietnam are any products covered by the existing antidumping and countervailing duty orders on corrosion-resistant steel from the People’s Republic of China and the Republic of Korea and the antidumping duty order on corrosion-resistant steel from Taiwan. *See Certain Corrosion-Resistant Steel Products from India, Italy, the People’s Republic of China, the Republic of Korea and Taiwan: Amended Final Affirmative Antidumping Determination for India and Taiwan, and Antidumping Duty Orders*, 81 FR 48390 (July 25, 2016); *see also Certain Corrosion-Resistant Steel Products from India, Italy, Republic of Korea and the People’s Republic of China: Countervailing Duty Order*, 81 FR 48387 (July 25, 2016). This exclusion does not apply to imports of corrosion-resistant steel that are entered, or withdrawn from warehouse, for consumption in the United States for which the relevant importer and exporter certifications have been completed and maintained and all other applicable certification requirements have been met such that the entry is entered into the United States as not subject to the antidumping and countervailing duty orders on corrosion-resistant steel from the People’s Republic of China, the antidumping and countervailing duty orders on corrosion-resistant steel from the Republic of Korea, or the antidumping duty order on corrosion-resistant steel from Taiwan.

The products subject to the investigation are currently classified in the Harmonized Tariff Schedule of the United States (HTSUS) under item numbers: 7210.30.0030, 7210.30.0060, 7210.41.0000, 7210.49.0030, 7210.49.0040, 7210.49.0045, 7210.49.0091, 7210.49.0095, 7210.61.0000, 7210.69.0000, 7210.70.6030, 7210.70.6060, 7210.70.6090, 7210.90.6000, 7210.90.9000, 7212.20.0000, 7212.30.1030, 7212.30.1090, 7212.30.3000, 7212.30.5000, 7212.40.1000, 7212.40.5000, 7212.50.0000, 7212.60.0000, 7225.91.0000, 7225.92.0000, 7226.99.0110, and 7226.99.0130.

The products subject to the investigation may also enter under the following HTSUS item numbers: 7210.90.1000, 7215.90.1000, 7215.90.3000, 7215.90.5000, 7217.20.1500, 7217.30.1530, 7217.30.1560, 7217.90.1000, 7217.90.5030, 7217.90.5060, 7217.90.5090, 7225.99.0090, 7226.99.0180, 7228.60.6000, 7228.60.8000, and 7229.90.1000. The HTSUS subheadings above are provided for convenience and customs purposes only. The written description of the scope of the investigation is dispositive.

Appendix II

List of Topics Discussed in the Preliminary Decision Memorandum

- I. Summary
- II. Background
- III. Period of Investigation
- IV. Scope Comments
- V. Affiliation and Single Entity Treatment
- VI. Discussion of the Methodology
- VII. Adjustments to Cash Deposit Rates for Export Subsidies in the Companion Countervailing Duty Investigation
- VIII. Currency Conversion

IX. Recommendation

[FR Doc. 2025–06134 Filed 4–9–25; 8:45 am]

BILLING CODE 3510–DS–P

DEPARTMENT OF COMMERCE

International Trade Administration

[A–122–871]

Certain Corrosion-Resistant Steel Products From Canada: Preliminary Affirmative Determination of Sales at Less Than Fair Value, Postponement of Final Determination, and Extension of Provisional Measures

AGENCY: Enforcement and Compliance, International Trade Administration, Department of Commerce.

SUMMARY: The U.S. Department of Commerce (Commerce) preliminarily determines that certain corrosion-resistant steel products (CORE) from Canada are being, or are likely to be, sold in the United States at less than fair value (LTFV). The period of investigation (POI) is July 1, 2023, through June 30, 2024. Interested parties are invited to comment on this preliminary determination.

DATES: Applicable April 10, 2025.

FOR FURTHER INFORMATION CONTACT: Reginald Anadio or Benjamin Blythe, AD/CVD Operations, Office IV, Enforcement and Compliance, International Trade Administration, U.S. Department of Commerce, 1401 Constitution Avenue NW, Washington, DC 20230; telephone: (202) 482–3166 or (202) 482–3457, respectively.

SUPPLEMENTARY INFORMATION:**Background**

This preliminary determination is made in accordance with section 733(b) of the Tariff Act of 1930, as amended (the Act). Commerce published the notice of initiation of this investigation in the *Federal Register* on October 2, 2024.¹ On January 28, 2025, Commerce postponed the preliminary determination of this investigation until

¹ See *Certain Corrosion-Resistant Steel Products from Australia, Brazil, Canada, Mexico, the Netherlands, South Africa, Taiwan, the Republic of Türkiye, the United Arab Emirates, and the Socialist Republic of Vietnam: Initiation of Less-Than-Fair-Value Investigations*, 89 FR 80196 (October 2, 2024) (*Initiation Notice*).

² See *Certain Corrosion-Resistant Steel Products from Australia, Brazil, Canada, Mexico, the Netherlands, South Africa, Taiwan, the Republic of Türkiye, the United Arab Emirates, and the Socialist Republic of Vietnam: Postponement of Preliminary Determinations in the Less-Than-Fair-Value Investigations*, 90 FR 8260 (January 28, 2025).

³ See Memorandum, “Decision Memorandum for the Preliminary Affirmative Determination in the Less-Than-Fair-Value Investigation of Certain Corrosion-Resistant Steel Products from Canada”

April 3, 2025.² For a complete description of the events that followed the initiation of this investigation, see the Preliminary Decision Memorandum.³ A list of topics included in the Preliminary Decision Memorandum is included as Appendix II to this notice. The Preliminary Decision Memorandum is a public document and is on file electronically via Enforcement and Compliance’s Antidumping and Countervailing Duty Centralized Electronic Service System (ACCESS). ACCESS is available to registered users at <https://access.trade.gov>. In addition, a complete version of the Preliminary Decision Memorandum can be accessed directly at <https://access.trade.gov/public/FRNoticesListLayout.aspx>.

Scope of the Investigation

The product covered by this investigation is CORE from Canada. For a complete description of the scope of this investigation, see Appendix I.

Scope Comments

In accordance with the *Preamble* to Commerce’s regulations,⁴ in the *Initiation Notice*, Commerce set aside a period of time for parties to raise issues regarding product coverage (*i.e.*, scope).⁵ Certain interested parties commented on the scope of the investigation as it appeared in the *Initiation Notice*. For a summary of the product coverage comments and rebuttal responses submitted to the record for this investigation and accompanying discussion and analysis of all comments timely received, see the Preliminary Scope Decision Memorandum.⁶ Commerce is not preliminarily modifying the scope language as it appeared in the *Initiation Notice*. See the scope in Appendix I to this notice. In the Preliminary Scope Decision Memorandum, Commerce established the deadline for parties to submit scope case and rebuttal briefs.⁷

dated concurrently with, and hereby adopted by, this notice (Preliminary Decision Memorandum).

⁴ See *Antidumping Duties; Countervailing Duties, Final Rule*, 62 FR 27296, 27323 (May 19, 1997) (*Preamble*).

⁵ See *Initiation Notice*, 89 FR at 80197.

⁶ See Memorandum, “Preliminary Scope Decision Memorandum,” dated concurrently with this notice (Preliminary Scope Decision Memorandum).

⁷ *Id.*

⁸ With two respondents under examination, Commerce normally calculates: (A) a weighted-average of the estimated weighted-average dumping margins calculated for the examined respondents; (B) a simple average of the estimated weighted-average dumping margins calculated for the examined respondents; and (C) a weighted-average of the estimated weighted-average dumping margins

Methodology

Commerce is conducting this investigation in accordance with section 731 of the Act. Commerce calculated export prices in accordance with section 772(a) of the Act and constructed export prices in accordance with section 772(b) of the Act. Commerce calculated normal value in accordance with section 773 of the Act. Furthermore, pursuant to sections 776(a) and (b) of the Act, Commerce has preliminarily relied upon facts otherwise available, with adverse inferences for Nova Steel Inc. For a full description of the methodology underlying the preliminary determination, see the Preliminary Decision Memorandum.

All-Others Rate

Sections 733(d)(1)(ii) and 735(c)(5)(A) of the Act provide that, in the preliminary determination, Commerce shall determine an estimated all-others rate for all exporters and producers not individually examined. This rate shall be an amount equal to the weighted average of the estimated weighted-average dumping margins established for exporters and producers individually investigated, excluding any zero and *de minimis* dumping margins, and any dumping margins determined entirely under section 776 of the Act.

Commerce has preliminarily calculated individual estimated weighted-average dumping margins for Stelco Inc. (Stelco) and ArcelorMittal Dofasco G.P. (AMD) that are not zero, *de minimis*, or based entirely on facts otherwise available. Thus, Commerce calculated the all-others rate by weight averaging the estimated weighted-average dumping margins that it calculated for Stelco and AMD by each company’s publicly-ranged values of sales of subject merchandise during the POI.⁸

Preliminary Determination

Commerce preliminarily determines that the following estimated weighted-average dumping margins exist:

calculated for the examined respondents using each company’s publicly-ranged U.S. sales values for the merchandise under consideration. Commerce then compares (B) and (C) to (A) and selects the rate closest to (A) as the most appropriate rate for all other producers and exporters. See, *e.g.*, *Ball Bearings and Parts Thereof from France, Germany, Italy, Japan, and the United Kingdom: Final Results of Antidumping Duty Administrative Reviews, Final Results of Changed-Circumstances Review, and Revocation of an Order in Part*, 75 FR 53661, 53662 (September 1, 2010), and accompanying Issues and Decision Memorandum at Comment 1. As complete publicly ranged sales data were available, Commerce based the all-others rate on the publicly ranged sales data of the mandatory respondents. For a complete analysis of the data, see the All-Others Rate Calculation Memorandum.

Exporter/producer	Weighted-average dumping margin (percent)	Cash deposit rate (adjusted for subsidy offset(s)) (percent)
Stelco Inc	5.93	Not Applicable.
ArcelorMittal Dofasco G.P./ArcelorMittal Coteau-du-Lac Limited Partnership ⁹	2.31	Not Applicable.
Nova Steel Inc	* 52.08	48.06. ¹⁰
All Others	2.60	Not Applicable.

⁹ Based on facts available with adverse inferences.

Suspension of Liquidation

In accordance with section 733(d)(2) of the Act, Commerce will direct U.S. Customs and Border Protection (CBP) to suspend liquidation of entries of subject merchandise, as described in Appendix I, entered, or withdrawn from warehouse, for consumption on or after the date of publication of this notice in the **Federal Register**. Further, pursuant to section 733(d)(1)(B) of the Act and 19 CFR 351.205(d), Commerce will instruct CBP to require a cash deposit equal to the estimated weighted-average dumping margin or the estimated all-others rate, as follows: (1) the cash deposit rate for the companies listed above will be equal to the company-specific estimated weighted-average dumping margins determined in this preliminary determination; (2) if the exporter is not a respondent identified above, but the producer is, then the cash deposit rate will be equal to the company-specific estimated weighted-average dumping margin established for that producer of the subject merchandise; and (3) the cash deposit rate for all other producers and exporters will be equal to the all-others estimated weighted-average dumping margin.

To determine the cash deposit rate, Commerce normally adjusts the estimated weighted-average dumping margin by the amount of domestic subsidy pass-through and export subsidies determined in a companion countervailing duty (CVD) proceeding when CVD provisional measures are in effect. Accordingly, where Commerce has made a preliminary affirmative determination for domestic subsidy pass-through or export subsidies, Commerce has offset the calculated estimated weighted-average dumping margin by the appropriate rate(s). Any such adjusted rates may be found in the

“Preliminary Determination” chart of estimated weighted-average dumping margins above. Should provisional measures in the companion CVD investigation expire prior to the expiration of provisional measures in this LTFV investigation, Commerce will direct CBP to begin collecting estimated antidumping duty cash deposits unadjusted for countervailed export subsidies at the time that the provisional CVD measures expire.

These suspension of liquidation instructions will remain in effect until further notice.

Disclosure

Commerce intends to disclose its calculations and the analysis it performed to parties to the proceeding within five days of any public announcement or, if there is no public announcement, within five days of the date of publication of this notice in the **Federal Register** in accordance with 19 CFR 351.224(b).

Consistent with 19 CFR 351.224(e), Commerce will analyze and, if appropriate, correct any timely allegations of significant ministerial errors by amending the preliminary determination. However, consistent with 19 CFR 351.224(d), Commerce will not consider incomplete allegations that do not address the significance standard under 19 CFR 351.224(g) following the preliminary determination. Instead, Commerce will address such allegations in the final determination together with issues raised in the case briefs or other written comments.

Verification

As provided in section 782(i)(1) of the Act, Commerce intends to verify the information relied upon in making its final determination.

Public Comment

Case briefs or other written comments, excluding scope comments, may be submitted to the Assistant Secretary for Enforcement and Compliance no later than seven days after the date on which the last verification report is issued in this investigation. Rebuttal briefs, limited to issues raised in the case briefs, may be

filed not later than five days after the date for filing case briefs.¹¹ Interested parties who submit case briefs or rebuttal briefs in this proceeding must submit: (1) a table of contents listing each issue; and (2) a table of authorities.¹²

As provided under 19 CFR 351.309(c)(2) and (d)(2), in prior proceedings we have encouraged interested parties to provide an executive summary of their brief that should be limited to five pages total, including footnotes. In this investigation, we instead request that interested parties provide at the beginning of their briefs a public, executive summary for each issue raised in their briefs.¹³ Further, we request that interested parties limit their executive summary of each issue to no more than 450 words, not including citations. We intend to use the executive summaries as the basis of the comment summaries included in the issues and decision memorandum that will accompany the final determination in this investigation. We request that interested parties include footnotes for relevant citations in the executive summary of each issue. Note that Commerce has amended certain of its requirements pertaining to the service of documents in 19 CFR 351.303(f).¹⁴

Pursuant to 19 CFR 351.310(c), interested parties who wish to request a hearing, limited to issues raised in the case and rebuttal briefs, must submit a written request to the Assistant Secretary for Enforcement and Compliance, U.S. Department of Commerce, within 30 days after the date of publication of this notice in the **Federal Register**. Requests should contain: (1) the party's name, address, and telephone number, (2) the number of participants and whether any participant is a foreign national, and (3)

⁹ Commerce preliminarily determines that ArcelorMittal Dofasco G.P. and ArcelorMittal Coteau-du-Lac Limited Partnership are a single entity. See Preliminary Decision Memorandum.

¹⁰ See *Certain Corrosion-Resistant Steel Products from Canada: Preliminary Affirmative Countervailing Duty Determination and Alignment of Final Determination With Final Antidumping Duty Determination*, 90 FR 9231 (February 10, 2025), and accompanying Preliminary Decision Memorandum at 54.

¹¹ See 19 CFR 351.309(d); see also *Administrative Protective Order, Service, and Other Procedures in Antidumping and Countervailing Duty Proceedings*, 88 FR 67069, 67077 (September 29, 2023) (*APO and Service Final Rule*).

¹² See 19 CFR 351.309(c)(2) and (d)(2).

¹³ We use the term “issue” here to describe an argument that Commerce would normally address in a comment of the Issues and Decision Memorandum.

¹⁴ See *APO and Service Final Rule*.

a list of the issues to be discussed. If a request for a hearing is made, Commerce intends to hold the hearing at a date and time to be determined. Parties should confirm by telephone the date, time, and location of the hearing two days before the scheduled date.

Postponement of Final Determination and Extension of Provisional Measures

Section 735(a)(2) of the Act provides that a final determination may be postponed until not later than 135 days after the date of the publication of the preliminary determination in the **Federal Register** if, in the event of an affirmative preliminary determination, a request for such postponement is made by exporters who account for a significant proportion of exports of the subject merchandise, or in the event of a negative preliminary determination, a request for such postponement is made by the petitioner. Section 351.210(e)(2) of Commerce's regulations requires that a request by exporters for postponement of the final determination be accompanied by a request for extension of provisional measures from a four-month period to a period not more than six months in duration.

On March 28, 2025, pursuant to 19 CFR 351.210(e), Stelco and AMD requested that Commerce postpone the final determination and that provisional measures be extended to a period not to exceed six months.¹⁵ In accordance with section 735(a)(2)(A) of the Act and 19 CFR 351.210(b)(2)(ii), because: (1) the preliminary determination is affirmative; (2) the requesting exporters account for a significant proportion of exports of the subject merchandise; and (3) no compelling reasons for denial exist, Commerce is postponing the final determination and extending the provisional measures from a four-month period to a period not greater than six months. Accordingly, Commerce will make its final determination no later than 135 days after the date of publication of this preliminary determination in the **Federal Register**.

U.S. International Trade Commission Notification

In accordance with section 733(f) of the Act, Commerce will notify the U.S. International Trade Commission (ITC) of its preliminary determination. If the final determination is affirmative, the ITC will determine before the later of 120 days after the date of this preliminary determination or 45 days

after the final determination whether these imports are materially injuring, or threaten material injury to, the U.S. industry.

Notification to Interested Parties

This determination is issued and published in accordance with sections 733(f) and 777(i)(1) of the Act and 19 CFR 351.205(c).

Dated: April 3, 2025.

Christopher Abbott,

Deputy Assistant Secretary for Policy and Negotiations, performing the non-exclusive functions and duties of the Assistant Secretary for Enforcement and Compliance.

Appendix I

Scope of the Investigation

The products covered by the investigation are certain flat-rolled steel products, either clad, plated, or coated with corrosion-resistant metals such as zinc, aluminum, or zinc-, aluminum-, nickel- or iron-based alloys, whether or not corrugated or painted, varnished, laminated, or coated with plastics or other non-metallic substances in addition to the metallic coating. The products covered include coils that have a width of 12.7 mm or greater, regardless of form of coil (*e.g.*, in successively superimposed layers, spirally oscillating, *etc.*). The products covered also include products not in coils (*e.g.*, in straight lengths) of a thickness less than 4.75 mm and a width that is 12.7 mm or greater and that measures at least 10 times the thickness. The products covered also include products not in coils (*e.g.*, in straight lengths) of a thickness of 4.75 mm or more and a width exceeding 150 mm and measuring at least twice the thickness. The products described above may be rectangular, square, circular, or other shape and include products of either rectangular or non-rectangular cross-section where such cross-section is achieved subsequent to the rolling process, *i.e.*, products which have been "worked after rolling" (*e.g.*, products which have been beveled or rounded at the edges).

For purposes of the width and thickness requirements referenced above:

(1) Where the nominal and actual measurements vary, a product is within the scope if application of either the nominal or actual measurement would place it within the scope based on the definitions set forth above, and

(2) where the width and thickness vary for a specific product (*e.g.*, the thickness of certain products with non-rectangular cross-section, the width of certain products with non-rectangular shape, *etc.*), the measurement at its greatest width or thickness applies.

Steel products included in the scope of the investigation are products in which: (1) iron predominates, by weight, over each of the other contained elements; and (2) the carbon content is 2 percent or less, by weight.

Subject merchandise also includes corrosion-resistant steel that has been further processed in a third country, including but not limited to annealing, tempering, painting, varnishing, trimming, cutting, punching and/

or slitting or any other processing that would not otherwise remove the merchandise from the scope of the investigation if performed in the country of manufacture of the in-scope corrosion resistant steel.

All products that meet the written physical description are within the scope of the investigation unless specifically excluded. The following products are outside of and/or specifically excluded from the scope of the investigation:

- Flat-rolled steel products either plated or coated with tin, lead, chromium, chromium oxides, both tin and lead ("terne plate") or both chromium and chromium oxides ("tin free steel"), whether or not painted, varnished or coated with plastics or other non-metallic substances in addition to the metallic coating;

- Clad products in straight lengths of 4.7625 mm or more in composite thickness and of a width which exceeds 150 mm and measures at least twice the thickness;

- Certain clad stainless flat-rolled products, which are three-layered corrosion-resistant carbon steel flat-rolled products less than 4.75 mm in composite thickness that consist of a carbon steel flat-rolled product clad on both sides with stainless steel in a 20%–60%–20% ratio; and

Also excluded from the scope of the antidumping duty investigation on corrosion resistant steel from Taiwan are any products covered by the existing antidumping duty order on corrosion-resistant steel from Taiwan. *See Certain Corrosion-Resistant Steel Products from India, Italy, the People's Republic of China, the Republic of Korea and Taiwan: Amended Final Affirmative Antidumping Determination for India and Taiwan, and Antidumping Duty Orders*, 81 FR 48390 (July 25, 2016); *Corrosion-Resistant Steel Products from Taiwan: Notice of Third Amended Final Determination of Sales at Less Than Fair Value Pursuant to Court Decision and Partial Exclusion from Antidumping Duty Order*, 88 FR 58245 (August 25, 2023).

Also excluded from the scope of the antidumping duty investigation on corrosion-resistant steel from the United Arab Emirates and the antidumping duty and countervailing duty investigations on corrosion-resistant steel from the Socialist Republic of Vietnam are any products covered by the existing antidumping and countervailing duty orders on corrosion-resistant steel from the People's Republic of China and the Republic of Korea and the antidumping duty order on corrosion-resistant steel from Taiwan. *See Certain Corrosion-Resistant Steel Products from India, Italy, the People's Republic of China, the Republic of Korea and Taiwan: Amended Final Affirmative Antidumping Determination for India and Taiwan, and Antidumping Duty Orders*, 81 FR 48390 (July 25, 2016); *see also Certain Corrosion-Resistant Steel Products from India, Italy, Republic of Korea and the People's Republic of China: Countervailing Duty Order*, 81 FR 48387 (July 25, 2016). This exclusion does not apply to imports of corrosion-resistant steel that are entered, or withdrawn from warehouse, for consumption in the United States for which the relevant importer and exporter certifications have been completed

¹⁵ See Stelco's Letter, "Stelco's Request for Postponement of Final Antidumping Determination," dated March 28, 2025; *see also* AMD's Letter, "Request to Postpone Final Determination," dated March 28, 2025.

and maintained and all other applicable certification requirements have been met such that the entry is entered into the United States as not subject to the antidumping and countervailing duty orders on corrosion-resistant steel from the People's Republic of China, the antidumping and countervailing duty orders on corrosion-resistant steel from the Republic of Korea, or the antidumping duty order on corrosion-resistant steel from Taiwan.

The products subject to the investigation are currently classified in the Harmonized Tariff Schedule of the United States (HTSUS) under item numbers: 7210.30.0030, 7210.30.0060, 7210.41.0000, 7210.49.0030, 7210.49.0040, 7210.49.0045, 7210.49.0091, 7210.49.0095, 7210.61.0000, 7210.69.0000, 7210.70.6030, 7210.70.6060, 7210.70.6090, 7210.90.6000, 7210.90.9000, 7212.20.0000, 7212.30.1030, 7212.30.1090, 7212.30.3000, 7212.30.5000, 7212.40.1560, 7212.40.5000, 7212.50.0000, 7212.60.0000, 7225.91.0000, 7225.92.0000, 7226.99.0110, and 7226.99.0130.

The products subject to the investigation may also enter under the following HTSUS item numbers: 7210.90.1000, 7215.90.1000, 7215.90.3000, 7215.90.5000, 7217.20.1500, 7217.30.1530, 7217.30.1560, 7217.90.1000, 7217.90.5030, 7217.90.5060, 7217.90.5090, 7225.99.0090, 7226.99.0180, 7228.60.6000, 7228.60.8000, and 7229.90.1000.

The HTSUS subheadings above are provided for convenience and customs purposes only. The written description of the scope of the investigation is dispositive.

Appendix II

List of Topics Discussed in the Preliminary Decision Memorandum

- I. Summary
- II. Background
- III. Period of Investigation
- IV. Scope Comments
- V. Affiliation and Single Entity Treatment
- VI. Application of Facts Available with Adverse Inferences
- VII. Discussion of the Methodology
- VIII. Adjustments to Cash Deposit Rates for Export Subsidies in the Companion Countervailing Duty Investigation
- IX. Currency Conversion
- X. Recommendation

[FR Doc. 2025-06135 Filed 4-9-25; 8:45 am]

BILLING CODE 3510-DS-P

DEPARTMENT OF COMMERCE

International Trade Administration

[A-489-855]

Certain Corrosion-Resistant Steel Products From the Republic of Türkiye: Preliminary Affirmative Determination of Sales at Less Than Fair Value, Postponement of Final Determination, and Extension of Provisional Measures

AGENCY: Enforcement and Compliance, International Trade Administration, Department of Commerce.

SUMMARY: The U.S. Department of Commerce (Commerce) preliminarily determines that certain corrosion-resistant steel products (CORE) from the Republic of Türkiye (Türkiye) are being, or are likely to be, sold in the United States at less than fair value (LTFV). The period of investigation is July 1, 2023, through June 30, 2024. Interested parties are invited to comment on this preliminary determination.

DATES: Applicable April 10, 2025.

FOR FURTHER INFORMATION CONTACT: Brittany Bauer or Olivia Woolverton, AD/CVD Operations, Office V, Enforcement and Compliance, International Trade Administration, U.S. Department of Commerce, 1401 Constitution Avenue NW, Washington, DC 20230; telephone: (202) 482-3860 or (202) 482-7452, respectively.

SUPPLEMENTARY INFORMATION:

Background

This preliminary determination is made in accordance with section 733(b) of the Tariff Act of 1930, as amended (the Act). Commerce published the notice of initiation of this investigation on October 2, 2024.¹ On January 28, 2025, Commerce postponed the preliminary determination of this investigation until April 3, 2025.² For a complete description of the events that followed the initiation of this investigation, see the Preliminary Decision Memorandum.³ A list of topics included in the Preliminary Decision Memorandum is included as Appendix II to this notice. The Preliminary Decision Memorandum is a public document and is on file electronically via Enforcement and Compliance's Antidumping and Countervailing Duty Centralized Electronic Service System (ACCESS). ACCESS is available to registered users at <https://access.trade.gov>. In addition, a complete version of the Preliminary Decision Memorandum can be accessed directly

¹ See *Certain Corrosion-Resistant Steel Products from Australia, Brazil, Canada, Mexico, the Netherlands, South Africa, Taiwan, the Republic of Türkiye, the United Arab Emirates, and the Socialist Republic of Vietnam: Initiation of Less-Than-Fair-Value Investigations*, 89 FR 80196 (October 2, 2024) (*Initiation Notice*).

² See *Certain Corrosion-Resistant Steel Products from Australia, Brazil, Canada, Mexico, the Netherlands, South Africa, Taiwan, the Republic of Türkiye, the United Arab Emirates, and the Socialist Republic of Vietnam: Postponement of Preliminary Determinations in the Less-Than-Fair-Value Investigation*, 90 FR 8260 (January 28, 2025).

³ See Memorandum, "Decision Memorandum for the Preliminary Affirmative Determination of Sales at Less-Than-Fair-Value in the Investigation of Certain Corrosion-Resistant Steel Products from the Republic of Türkiye," dated concurrently with, and hereby adopted by, this notice (Preliminary Decision Memorandum).

at <https://access.trade.gov/public/FRNoticesListLayout.aspx>.

Scope of the Investigation

The product covered by this investigation is CORE from Türkiye. For a complete description of the scope of this investigation, see Appendix I.

Scope Comments

In accordance with the *Preamble* to Commerce's regulations,⁴ in the *Initiation Notice*, Commerce set aside a period of time for parties to raise issues regarding product coverage (*i.e.*, scope).⁵ Certain interested parties commented on the scope of the investigation as it appeared in the *Initiation Notice*. For a summary of the product coverage comments and rebuttal responses submitted to the record for this investigation and accompanying discussion and analysis of all comments timely received, see the Preliminary Scope Decision Memorandum.⁶ Commerce is not preliminarily modifying the scope language as it appeared in the *Initiation Notice*. In the Preliminary Scope Decision Memorandum, Commerce established the deadline for parties to submit scope case and rebuttal briefs.⁷

Methodology

Commerce is conducting this investigation in accordance with section 731 of the Act. Commerce calculated export prices in accordance with sections 772(a) of the Act. Normal value is calculated in accordance with section 773 of the Act. Furthermore, pursuant to sections 776(a) and (b) of the Act, Commerce has preliminarily relied upon partial facts otherwise available, with adverse inferences, in determining an estimated weighted-average dumping margin for Borcelik.⁸ For a full description of the methodology underlying the preliminary determination, see the Preliminary Decision Memorandum.

All-Others Rate

Sections 733(d)(1)(ii) and 735(c)(5)(A) of the Act provide that in the preliminary determination Commerce shall determine an estimated all-others rate for all exporters and producers not

⁴ See *Antidumping Duties; Countervailing Duties, Final Rule*, 62 FR 27296, 27323 (May 19, 1997) (*Preamble*).

⁵ See *Initiation Notice*, 89 FR at 80197.

⁶ See Memorandum, "Preliminary Scope Decision Memorandum," dated concurrently with this notice (Preliminary Scope Decision Memorandum).

⁷ *Id.*

⁸ Borcelik consists of Borcelik Çelik Sanayii Ticaret A.Ş., ArcelorMittal Çelik Ticaret A.Ş., Bamesa Çelik Servis San. Ve Tic. A.Ş. and Bamesa Muradiye Demir Çelik San. Ve Tic. A.Ş.

individually examined. This rate shall be an amount equal to the weighted average of the estimated weighted-average dumping margins established for exporters and producers individually investigated, excluding any zero and *de minimis* margins, and any margins determined entirely under section 776 of the Act.

Commerce preliminarily calculated an estimated weighted-average dumping

margin of zero for Borcelik. Therefore, the only estimated weighted-average dumping margin that is not zero, *de minimis*, or based entirely on facts available is the rate calculated for Yıldız Demir Çelik Sanayi A.S. and Yıldız Entegre Ağaç Sanayi ve Ticaret A.S. (collectively, YDÇ). Consequently, the estimated weighted-average dumping margin calculated for YDÇ is also

assigned as the estimated weighted-average dumping margin for all-other producers and exporters in this investigation.

Preliminary Determination

Commerce preliminarily determines that the following estimated weighted-average dumping margins exist:

Exporter or producer	Estimated weighted-average dumping margin (percent)
Borcelik Celik Sanayii Ticaret A.S., ArcelorMittal Çelik Ticaret A.Ş., Bamesa Celik Servısı San. Ve Tic. A.Ş. and Bamesa Muradiye Demir Çelik San. Ve Tic. A.Ş	0.00
Yıldız Demir Çelik Sanayi A.S., Yıldız Entegre Ağaç Sanayi ve Ticaret A.S	15.18
All Others	15.18

Suspension of Liquidation

In accordance with section 733(d)(2) of the Act, Commerce will direct U.S. Customs and Border Protection (CBP) to suspend liquidation of entries of subject merchandise, as described in Appendix I, entered, or withdrawn from warehouse, for consumption on or after the date of publication of this notice in the **Federal Register**.

For this preliminary determination, Commerce has determined for Borcelik an estimated weighted-average dumping margin of zero percent. Therefore, for merchandise produced and exported by Borcelik, CBP will not suspend the liquidation of entries of the subject merchandise, as described in Appendix I, entered, or withdrawn from warehouse, for consumption on or after the date of publication of this notice in the **Federal Register**. Further, CBP will not require a cash deposit of estimated antidumping duties for such entries of subject merchandise produced and exported by Borcelik. For imports of CORE produced by Borcelik and exported by a different company, or produced by a different company and exported by Borcelik, Commerce will instruct CBP to suspend liquidation and require a cash deposit for estimated antidumping duties as stipulated below.

Should the final estimated weighted-average dumping margin be zero or *de minimis* (i.e., less than two percent) for Borcelik, entries of shipments of CORE produced and exported by Borcelik will be excluded from the potential antidumping duty order. Such exclusion is not applicable to CORE exported to the United States by Borcelik where the CORE was produced by a different company, or to CORE produced by Borcelik and exported by a different company. Under those conditions, the

cash deposit requirements for entries of CORE either produced by Borcelik or exported by Borcelik (but not both) will be determined under the cash deposit hierarchy set forth below.

Further, pursuant to section 733(d)(1)(B) of the Act and 19 CFR 351.205(d), Commerce will instruct CBP to require a cash deposit equal to the estimated weighted-average dumping margin, as follows: (1) the cash deposit rate for YDÇ will be equal to YDÇ's estimated weighted-average dumping margin determined in this preliminary determination; (2) if the exporter is not YDÇ, but YDÇ is the producer, then the cash deposit rate will be equal to YDÇ's estimated weighted-average dumping margin established for that producer of the subject merchandise; and (3) the cash deposit rate for all other producers and exporters will be equal to the all-others estimated weighted-average dumping margin.

These suspension of liquidation instructions and cash deposit requirements will remain in effect until further notice.

Disclosure

Commerce intends to disclose its calculations and analysis performed to interested parties in this preliminary determination within five days of any public announcement or, if there is no public announcement, within five days of the date of publication of this notice in the **Federal Register**, in accordance with 19 CFR 351.224(b).

Consistent with 19 CFR 351.224(e), Commerce will analyze and, if appropriate, correct any timely allegations of significant ministerial errors by amending the preliminary determination. However, consistent with 19 CFR 351.224(d), Commerce will not consider incomplete allegations that

do not address the significance standard under 19 CFR 351.224(g) following the preliminary determination. Instead, Commerce will address such allegations in the final determination together with issues raised in the case briefs or other written comments.

Verification

As provided in section 782(i)(1) of the Act, Commerce intends to verify the information relied upon in making its final determination.

Public Comment

Case briefs or other written comments, excluding scope comments, may be submitted to the Assistant Secretary for Enforcement and Compliance no later than seven days after the date on which the last verification report is issued in this investigation. Rebuttal briefs, limited to issues raised in the case briefs, may be filed no later than five days after the date for filing case briefs.⁹ Interested parties who submit case briefs or rebuttal briefs in this proceeding must submit: (1) a table of contents listing each issue; and (2) a table of authorities.¹⁰

As provided under 19 CFR 351.309(c)(2) and (d)(2), in prior proceedings we have encouraged interested parties to provide an executive summary of their briefs that should be limited to five pages total, including footnotes. In this investigation, we instead request that interested parties provide at the beginning of their briefs a public, executive summary for each issue raised

⁹ See 19 CFR 351.309; see also 19 CFR 351.303 (for general filing requirements).

¹⁰ See 19 CFR 351.309(c)(2) and (d)(2).

in their briefs.¹¹ Further, we request that interested parties limit their public executive summary of each issue to no more than 450 words, not including citations. We intend to use the public executive summaries as the basis of the comment summaries included in the issues and decision memorandum that will accompany the final determination. We request that interested parties include footnotes for relevant citations in the public executive summary of each issue. Note that Commerce has amended certain of its requirements pertaining to the service of documents in 19 CFR 351.303(f).¹²

Pursuant to 19 CFR 351.310(c), interested parties who wish to request a hearing, limited to issues raised in the case and rebuttal briefs, must submit a written request to the Assistant Secretary for Enforcement and Compliance, U.S. Department of Commerce, within 30 days after the date of publication of this notice. Requests should contain: (1) the party's name, address, and telephone number; (2) the number of participants and whether any participant is a foreign national; and (3) a list of the issues to be discussed. If a request for a hearing is made, Commerce intends to hold the hearing at a time and date to be determined. Parties should confirm by telephone the date, time, and location of the hearing two days before the scheduled date.

Postponement of Final Determination and Extension of Provisional Measures

Section 735(a)(2) of the Act provides that a final determination may be postponed until not later than 135 days after the date of the publication of the preliminary determination if, in the event of an affirmative preliminary determination, a request for such postponement is made by exporters who account for a significant proportion of exports of the subject merchandise, or in the event of a negative preliminary determination, a request for such postponement is made by the petitioner. Section 351.210(e)(2) of Commerce's regulations requires that a request by exporters for postponement of the final determination be accompanied by a request for extension of provisional measures from a four-month period to a period not more than six months in duration.

On January 20, 2025, pursuant to 19 CFR 351.210(b)(2)(ii), Borcelik and YDC requested that Commerce postpone the final determination and that provisional

measures be extended to a period not to exceed six months.¹³ In accordance with section 735(a)(2)(A) of the Act and 19 CFR 351.210(b)(2)(ii), because: (1) the preliminary determination is affirmative; (2) the requesting exporters account for a significant proportion of exports of the subject merchandise; and (3) no compelling reasons for denial exist, Commerce is postponing the final determination and extending the provisional measures from a four-month period to a period not greater than six months. Accordingly, Commerce will make its final determination no later than 135 days after the date of publication of this preliminary determination.

U.S. International Trade Commission (ITC) Notification

In accordance with section 733(f) of the Act, Commerce will notify the ITC of its preliminary determination. If the final determination is affirmative, the ITC will determine before the later of 120 days after the date of this preliminary determination or 45 days after our final determination whether imports of CORE from Türkiye are materially injuring, or threaten material injury to, the U.S. industry.

Notification to Interested Parties

This determination is issued and published in accordance with sections 733(f) and 777(i)(1) of the Act, and 19 CFR 351.205(c).

Dated: April 3, 2025.

Christopher Abbott,

Deputy Assistant Secretary for Policy and Negotiations, performing the non-exclusive functions and duties of the Assistant Secretary for Enforcement and Compliance.

Appendix I—Scope of the Investigation

The products covered by this investigation are certain flat-rolled steel products, either clad, plated, or coated with corrosion-resistant metals such as zinc, aluminum, or zinc-, aluminum-, nickel- or iron-based alloys, whether or not corrugated or painted, varnished, laminated, or coated with plastics or other non-metallic substances in addition to the metallic coating. The products covered include coils that have a width of 12.7 mm or greater, regardless of form of coil (*e.g.*, in successively superimposed layers, spirally oscillating, *etc.*). The products covered also include products not in coils (*e.g.*, in straight lengths) of a thickness less than 4.75 mm and a width that is 12.7 mm or greater and that measures at least 10 times the thickness. The products covered also include products not in coils (*e.g.*, in straight lengths) of a thickness of 4.75 mm or more and a width exceeding 150 mm and measuring at least

twice the thickness. The products described above may be rectangular, square, circular, or other shape and include products of either rectangular or non-rectangular cross-section where such cross-section is achieved subsequent to the rolling process, *i.e.*, products which have been "worked after rolling" (*e.g.*, products which have been beveled or rounded at the edges).

For purposes of the width and thickness requirements referenced above:

(1) Where the nominal and actual measurements vary, a product is within the scope if application of either the nominal or actual measurement would place it within the scope based on the definitions set forth above, and

(2) where the width and thickness vary for a specific product (*e.g.*, the thickness of certain products with non-rectangular cross-section, the width of certain products with non-rectangular shape, *etc.*), the measurement at its greatest width or thickness applies.

Steel products included in the scope of these investigations are products in which: (1) iron predominates, by weight, over each of the other contained elements; and (2) the carbon content is 2 percent or less, by weight.

Subject merchandise also includes corrosion-resistant steel that has been further processed in a third country, including but not limited to annealing, tempering, painting, varnishing, trimming, cutting, punching and/or slitting or any other processing that would not otherwise remove the merchandise from the scope of the investigation if performed in the country of manufacture of the in-scope corrosion resistant steel.

All products that meet the written physical description are within the scope of the investigation unless specifically excluded. The following products are outside of and/or specifically excluded from the scope of this investigation:

- Flat-rolled steel products either plated or coated with tin, lead, chromium, chromium oxides, both tin and lead ("terne plate") or both chromium and chromium oxides ("tin free steel"), whether or not painted, varnished or coated with plastics or other non-metallic substances in addition to the metallic coating;

- Clad products in straight lengths of 4.7625 mm or more in composite thickness and of a width which exceeds 150 mm and measures at least twice the thickness;

- Certain clad stainless flat-rolled products, which are three-layered corrosion-resistant carbon steel flat-rolled products less than 4.75 mm in composite thickness that consist of a carbon steel flat-rolled product clad on both sides with stainless steel in a 20%–60%–20% ratio; and

Also excluded from the scope of the antidumping duty investigation on corrosion resistant steel from Taiwan are any products covered by the existing antidumping duty order on corrosion-resistant steel from Taiwan. See *Certain Corrosion-Resistant Steel Products from India, Italy, the People's Republic of China, the Republic of Korea and Taiwan: Amended Final Affirmative Antidumping Determination for India and Taiwan, and Antidumping Duty Orders*, 81 FR 48390 (July 25, 2016); *Corrosion-Resistant*

¹¹ We use the term "issue" here to describe an argument that Commerce would normally address in a comment of the Issues and Decision Memorandum.

¹² See *APO and Service Final Rule*.

¹³ See Borcelik and YDC's Letter, "Request for Postponement of Final Determination," dated January 20, 2024{sic}.

Steel Products from Taiwan: Notice of Third Amended Final Determination of Sales at Less Than Fair Value Pursuant to Court Decision and Partial Exclusion from Antidumping Duty Order, 88 FR 58245 (August 25, 2023).

Also excluded from the scope of the antidumping duty investigation on corrosion-resistant steel from the United Arab Emirates and the antidumping duty and countervailing duty investigations on corrosion-resistant steel from the Socialist Republic of Vietnam are any products covered by the existing antidumping and countervailing duty orders on corrosion-resistant steel from the People's Republic of China and the Republic of Korea and the antidumping duty order on corrosion-resistant steel from Taiwan. *See Certain Corrosion-Resistant Steel Products from India, Italy, the People's Republic of China, the Republic of Korea and Taiwan: Amended Final Affirmative Antidumping Determination for India and Taiwan, and Antidumping Duty Orders*, 81 FR 48390 (July 25, 2016); *see also Certain Corrosion-Resistant Steel Products from India, Italy, Republic of Korea and the People's Republic of China: Countervailing Duty Order*, 81 FR 48387 (July 25, 2016). This exclusion does not apply to imports of corrosion-resistant steel that are entered, or withdrawn from warehouse, for consumption in the United States for which the relevant importer and exporter certifications have been completed and maintained and all other applicable certification requirements have been met such that the entry is entered into the United States as not subject to the antidumping and countervailing duty orders on corrosion-resistant steel from the People's Republic of China, the antidumping and countervailing duty orders on corrosion-resistant steel from the Republic of Korea, or the antidumping duty order on corrosion-resistant steel from Taiwan.

The products subject to the investigation are currently classified in the Harmonized Tariff Schedule of the United States (HTSUS) under item numbers: 7210.30.0030, 7210.30.0060, 7210.41.0000, 7210.49.0030, 7210.49.0040, 7210.49.0045, 7210.49.0091, 7210.49.0095, 7210.61.0000, 7210.69.0000, 7210.70.6030, 7210.70.6060, 7210.70.6090, 7210.90.6000, 7210.90.9000, 7212.20.0000, 7212.30.1030, 7212.30.1090, 7212.30.3000, 7212.30.5000, 7212.40.1000, 7212.40.5000, 7212.50.0000, 7212.60.0000, 7225.91.0000, 7225.92.0000, 7226.99.0110, and 7226.99.0130.

The products subject to the investigation may also enter under the following HTSUS item numbers: 7210.90.1000, 7215.90.1000, 7215.90.3000, 7215.90.5000, 7217.20.1500, 7217.30.1530, 7217.30.1560, 7217.90.1000, 7217.90.5030, 7217.90.5060, 7217.90.5090, 7225.99.0090, 7226.99.0180, 7228.60.6000, 7228.60.8000, and 7229.90.1000.

The HTSUS subheadings above are provided for convenience and customs purposes only. The written description of the scope of the investigation is dispositive.

Appendix II—List of Topics Discussed in the Preliminary Decision Memorandum

I. Summary

- II. Background
- III. Period of Investigation
- IV. Scope Comments
- V. Affiliation and Single Entity Treatment
- VI. Application of Facts Available and Use of Adverse Inferences
- VII. Discussion of the Methodology
- VIII. Currency Conversion
- IX. Recommendation

[FR Doc. 2025–06140 Filed 4–9–25; 8:45 am]

BILLING CODE 3510–DS–P

DEPARTMENT OF COMMERCE

International Trade Administration

[A–552–843]

Certain Corrosion-Resistant Steel Products From the Socialist Republic of Vietnam: Preliminary Affirmative Determination of Sales at Less Than Fair Value, Postponement of Final Determination, and Extension of Provisional Measures

AGENCY: Enforcement and Compliance, International Trade Administration, Department of Commerce.

SUMMARY: The U.S. Department of Commerce (Commerce) preliminarily determines that certain corrosion-resistant steel products (CORE) from the Socialist Republic of Vietnam (Vietnam) are being, or are likely to be, sold in the United States at less than fair value (LTFV). The period of investigation (POI) is January 1, 2024, through June 30, 2024. Interested parties are invited to comment on this preliminary determination.

DATES: Applicable April 10, 2025.

FOR FURTHER INFORMATION CONTACT: Jacob Waddell, AD/CVD Operations, Office VI, Enforcement and Compliance, International Trade Administration, U.S. Department of Commerce, 1401 Constitution Avenue NW, Washington, DC 20230; telephone: (202) 482–1369.

SUPPLEMENTARY INFORMATION:

Background

This preliminary determination is made in accordance with section 733(b) of the Tariff Act of 1930, as amended (the Act). Commerce published the notice of initiation of this investigation on October 2, 2024.¹ On January 28, 2025, Commerce postponed the preliminary determination of this investigation until April 3, 2025.² For a

¹ See *Certain Corrosion-Resistant Steel Products from Australia, Brazil, Canada, Mexico, the Netherlands, South Africa, Taiwan, the Republic of Türkiye, the United Arab Emirates, and the Socialist Republic of Vietnam: Initiation of Less-than-Fair-Value Investigations*, 89 FR 80196 (October 2, 2024) (*Initiation Notice*).

² See *Certain Corrosion-Resistant Steel Products from Australia, Brazil, Canada, Mexico, the*

complete description of the events that followed the initiation of this investigation, *see* the Preliminary Decision Memorandum.³ A list of topics included in the Preliminary Decision Memorandum is included as Appendix II to this notice. The Preliminary Decision Memorandum is a public document and is on file electronically via Enforcement and Compliance's Antidumping and Countervailing Duty Centralized Electronic Service System (ACCESS). ACCESS is available to registered users at <https://access.trade.gov>. In addition, a complete version of the Preliminary Decision Memorandum can be accessed directly at <https://access.trade.gov/public/FRNoticesListLayout.aspx>.

Scope of the Investigation

The product covered by this investigation is CORE from Vietnam. For a complete description of the scope of this investigation, *see* Appendix I.

Scope Comments

In accordance with the *Preamble* to Commerce's regulations,⁴ in the *Initiation Notice*, Commerce set aside a period of time for parties to raise issues regarding product coverage (*i.e.*, scope).⁵ Certain interested parties commented on the scope of the investigation as it appeared in the *Initiation Notice*. For a summary of the product coverage comments and rebuttal responses submitted to the record for this investigation, and accompanying discussion and analysis of all comments timely received, *see* the Preliminary Scope Decision Memorandum.⁶ Commerce is not preliminarily modifying the scope language as it appeared in the *Initiation Notice*. *See* the scope in Appendix I to this notice. In the Preliminary Scope Decision Memorandum, Commerce established the deadline for parties to submit scope case and rebuttal briefs.⁷

Netherlands, South Africa, Taiwan, the Republic of Türkiye, the United Arab Emirates, and the Socialist Republic of Vietnam: Postponement of Preliminary Determinations in the Less-than-Fair-Value Investigations, 90 FR 8260 (January 28, 2025).

³ See Memorandum, "Decision Memorandum for the Preliminary Affirmative Determination in the Less-Than-Fair-Value Investigation of Certain Corrosion-Resistant Steel Products from the Socialist Republic of Vietnam," dated concurrently with, and hereby adopted by, this notice (Preliminary Decision Memorandum).

⁴ See *Antidumping Duties; Countervailing Duties, Final Rule*, 62 FR 27296, 27323 (May 19, 1997) (*Preamble*).

⁵ See *Initiation Notice*, 89 FR at 80197.

⁶ See Memorandum, "Preliminary Scope Decision Memorandum," dated concurrently with this notice (Preliminary Scope Decision Memorandum).

⁷ *Id.*

Methodology

Commerce is conducting this investigation in accordance with section 731 of the Act. Commerce has calculated export prices in accordance with section 772(a) of the Act. Commerce has calculated constructed export prices in accordance with section 772(b) of the Act. Because Vietnam is a non-market economy, within the meaning of section 771(18) of the Act, Commerce has calculated normal value in accordance with section 773(c) of the Act. Furthermore, pursuant to sections

776(a) and (b) of the Act, Commerce has preliminarily relied upon facts otherwise available, with adverse inferences, for the Vietnam-wide entity, which includes 12 companies.⁸ In addition, pursuant to sections 776(a) and (b) of the Act, Commerce has preliminarily relied upon facts otherwise available, with adverse inferences, in part, for Ton Dong A Corporation. For a full description of the methodology underlying Commerce’s preliminary determination, see the Preliminary Decision Memorandum.

Combination Rates

In the *Initiation Notice*,⁹ Commerce stated that it would calculate producer/exporter combination rates for the respondents that are eligible for a separate rate in this investigation. Policy Bulletin 05.1 describes this practice.¹⁰

Preliminary Determination

Commerce preliminarily determines that the following estimated weighted-average dumping margins exist:

Producer	Exporter	Weighted-average dumping margin (percent)	Cash deposit rate (adjusted for subsidy offset(s)) (percent) ¹¹
Hoa Sen Group/Hoa Sen Nghe An One Member Limited Liabilities Company/Hoa Sen Nhon Hoi—Binh Dinh One Member Limited Liabilities Company ¹² .	Hoa Sen Group/Hoa Sen Nghe An One Member Limited Liabilities Company/Hoa Sen Nhon Hoi—Binh Dinh One Member Limited Liabilities Company.	59.00	N/A
Ton Dong A Corporation	Ton Dong A Corporation	39.84	N/A
China Steel and Nippon Steel Viet Nam Joint Stock Company.	China Steel and Nippon Steel Viet Nam Joint Stock Company.	49.42	N/A
Hoa Phat Steel Sheet Limited Liability Company	Hoa Phat Steel Sheet Limited Liability Company	49.42	N/A
Maruichi Sun Steel Joint Stock Company	Maruichi Sun Steel Joint Stock Company	49.42	N/A
Nam Kim Steel Joint Stock Company	Nam Kim Steel Joint Stock Company	49.42	N/A
Pomina Flat Steel Joint Stock Company	Pomina Flat Steel Joint Stock Company	49.42	N/A
Sam Hwan Vina Co., Ltd	Sam Hwan Vina Co., Ltd	49.42	N/A
Southern Steel Sheet Co., Ltd	Southern Steel Sheet Co., Ltd	49.42	N/A
Tay Nam Steel Manufacturing & Trading Co., Ltd	Tay Nam Steel Manufacturing & Trading Co., Ltd	49.42	N/A
TVP Steel Trading Joint Stock Company	TVP Steel Trading Joint Stock Company	49.42	N/A
Viet Phap Steel Corrugated Joint Stock Company.	Viet Phap Steel Corrugated Joint Stock Company.	49.42	N/A
Vietnam-Wide Entity		* 88.12	45.80

* Rate based on facts available with adverse inferences.

Suspension of Liquidation

In accordance with section 733(d)(2) of the Act, Commerce will direct U.S. Customs and Border Protection (CBP) to suspend liquidation of subject merchandise as described in the scope of the investigation section entered, or withdrawn from warehouse, for consumption on or after the date of publication of this notice in the **Federal Register**, as discussed below. Further, pursuant to section 733(d)(1)(B) of the Act and 19 CFR 351.205(d), Commerce will instruct CBP to require a cash deposit equal to the weighted average amount by which normal value exceeds

U.S. price, as indicated in the chart above as follows: (1) for the producer/exporter combinations listed in the table above, the cash deposit rate is equal to the estimated weighted-average dumping margin listed for that combination in the table; (2) for all combinations of Vietnam producers/exporters of merchandise under consideration that have not established eligibility for their own separate rates, the cash deposit rate will be equal to the estimated weighted-average dumping margin established for the Vietnam-wide entity; and (3) for all third-country exporters of merchandise under

consideration not listed in the table above, the cash deposit rate is the cash deposit rate applicable to the Vietnam producer/exporter combination (or the Vietnam-wide entity) that supplied that third-country exporter.

To determine the cash deposit rate, Commerce normally adjusts the estimated weighted-average dumping margin by the amount of domestic subsidy pass-through and export subsidies determined in a companion countervailing duty (CVD) proceeding when CVD provisional measures are in effect. Accordingly, where Commerce has made a preliminary affirmative

⁸ These companies are: (1) 190 Steel Pipe Co., Ltd.; (2) Formosa Ha Tinh Steel Corporation.; (3) Hoa Phat Group Joint Stock Company; (4) Hoa Phat Steel Pipe Co., Ltd.; (5) NS BlueScope Vietnam Co., Ltd.; (6) TVP Steel Joint Stock Company; (7) Vietnam Germany Steel Joint Stock Company; (8) Vietnam Steel Pipe Co., Ltd.; (9) Vina One Steel Manufacturing Corporation; (10) VN STEEL—Thang Long Coated Sheets Joint Stock Company; (11) Vnsteel—Phu My Flat Steel Co., Ltd; and (12) VN STEEL—Vietnam Steel Corp.

⁹ See *Initiation Notice*, 89 FR at 80202.

¹⁰ See Enforcement and Compliance’s Policy Bulletin No. 05.1, regarding, “Separate-Rates

Practice and Application of Combination Rates in Antidumping Investigations Involving Non-Market Economy Countries,” (April 5, 2005) (Policy Bulletin 05.1), available on Commerce’s website at <https://enforcement.trade.gov/policy/bull05-1.pdf>.

¹¹ We are not applying an export subsidy offset to the mandatory respondents because we found no export subsidies were provided to HSG and TDA. See *Certain Corrosion-Resistant Steel Products from the Socialist Republic of Vietnam: Preliminary Affirmative Countervailing Duty Determination, and Alignment of Final Determination with Antidumping Duty Determination*, 90 FR 9235 (February 10, 2025), and accompanying Preliminary Decision Memorandum. Similarly, no offset applies

to the separate rate companies because their rate is based on the rates determined for HSG and TDA. For the Vietnam-wide entity, we have determined the amount of the offset based on the *CVD Preliminary Determination* for the non-responsive companies subject to total AFA. See also Memorandum, “Calculation of CVD Subsidy Offset for the Vietnam-Wide Entity,” dated concurrently with this **Federal Register** Notice.

¹² Commerce preliminarily determines that HSG, Hoa Sen Nghe An One Member Limited Liabilities Company, and Hoa Sen Nhon Hoi—Binh Dinh One Member Limited Liabilities Company are a single entity. See Preliminary Decision Memorandum.

determination for domestic subsidy pass-through or export subsidies, Commerce has offset the calculated estimated weighted-average dumping margin by the appropriate rate(s). Any such adjusted rates may be found in the "Preliminary Determination" chart of estimated weighted-average dumping margins above.

Should provisional measures in the companion CVD investigation expire prior to the expiration of provisional measures in this LTFV investigation, Commerce will direct CBP to begin collecting cash deposits at a rate equal to the estimated weighted-average dumping margins calculated in this preliminary determination unadjusted for the passed-through domestic subsidies or for export subsidies at the time the CVD provisional measures expire.

These suspension of liquidation instructions will remain in effect until further notice.

Disclosure

Commerce intends to disclose to interested parties the calculations performed in connection with this preliminary determination within five days of its public announcement or, if there is no public announcement, within five days of the date of publication of this notice in accordance with 19 CFR 351.224(b).

Consistent with 19 CFR 351.224(e), Commerce will analyze and, if appropriate, correct any timely allegations of significant ministerial errors by amending the preliminary determination. However, consistent with 19 CFR 351.224(d), Commerce will not consider incomplete allegations that do not address the significance standard under 19 CFR 351.224(g) following the preliminary determination. Instead, Commerce will address such allegations in the final determination together with issues raised in the case briefs or other written comments.

Verification

As provided in section 782(i)(1) of the Act, Commerce intends to verify information relied upon in making its final determination.

Public Comment

Case briefs or other written comments, excluding scope comments, may be submitted to the Assistant Secretary for Enforcement and Compliance no later than seven days after the date on which the last verification report is issued in this

investigation.¹³ Rebuttal briefs, limited to issues raised in the case briefs, may be filed not later than five days after the date for filing case briefs.¹⁴ Interested parties who submit case briefs or rebuttal briefs in this proceeding must submit: (1) a table of contents listing each issue; and (2) a table of authorities.¹⁵

As provided under 19 CFR 351.309(c)(2) and (d)(2), in prior proceedings we have encouraged interested parties to provide an executive summary of their brief that should be limited to five pages total, including footnotes. In this investigation, we instead request that interested parties provide at the beginning of their briefs a public, executive summary for each issue raised in their briefs.¹⁶ Further, we request that interested parties limit their executive summary of each issue to no more than 450 words, not including citations. We intend to use the executive summaries as the basis of the comment summaries included in the issues and decision memorandum that will accompany the final determination in this investigation. We request that interested parties include footnotes for relevant citations in the executive summary of each issue. Note that Commerce has amended certain of its requirements pertaining to the service of documents in 19 CFR 351.303(f).¹⁷

Pursuant to 19 CFR 351.310(c), interested parties who wish to request a hearing, limited to issues raised in the case and rebuttal briefs, must submit a written request to the Assistant Secretary for Enforcement and Compliance, U.S. Department of Commerce, within 30 days after the date of publication of this notice. Requests should contain: (1) the party's name, address, and telephone number; (2) the number of participants and whether any participant is a foreign national; and (3) a list of the issues to be discussed. If a request for a hearing is made, Commerce intends to hold the hearing at a date and time to be determined. Parties should confirm by telephone the date, time, and location of the hearing two days before the scheduled date.

¹³ See 19 CFR 351.309(c)(1)(i); see also 19 CFR 351.303 (for general filing requirements).

¹⁴ See 19 CFR 351.309(d); see also *Administrative Protective Order, Service, and Other Procedures in Antidumping and Countervailing Duty Proceedings*, 88 FR 67069, 67077 (September 29, 2023) (*APO and Service Final Rule*).

¹⁵ See 19 CFR 351.309(c)(2) and (d)(2).

¹⁶ We use the term "issue" here to describe an argument that Commerce would normally address in a comment of the Issues and Decision Memorandum.

¹⁷ See *APO and Service Final Rule*.

Postponement of Final Determination and Extension of Provisional Measures

Section 735(a)(2) of the Act provides that a final determination may be postponed until not later than 135 days after the date of the publication of the preliminary determination if, in the event of an affirmative preliminary determination, a request for such postponement is made by exporters who account for a significant proportion of exports of the subject merchandise, or in the event of a negative preliminary determination, a request for such postponement is made by the petitioners. Pursuant to 19 CFR 351.210(e)(2), Commerce requires that requests by respondents for postponement of a final antidumping determination be accompanied by a request for extension of provisional measures from a four-month period to a period not more than six months in duration.

In March 2025, pursuant to 19 CFR 351.210(e), HSG and TDA requested that Commerce postpone the final determination and that provisional measures be extended to a period not to exceed six months.¹⁸ Additionally, pursuant to 19 CFR 351.210(b)(2)(i) and (e)(1), the petitioners requested that Commerce postpone the final determination and that provisional measures be extended up to 135 days contingent upon negative preliminary determinations in these investigations.¹⁹ In accordance with section 735(a)(2)(A) of the Act and 19 CFR 351.210(b)(2)(ii), because: (1) the preliminary determination is affirmative; (2) the requesting exporter accounts for a significant proportion of exports of the subject merchandise; and (3) no compelling reasons for denial exist, Commerce is postponing the final determination and extending the provisional measures from a four-month period to a period not greater than six months. Accordingly, Commerce will make its final determination no later than 135 days after the date of publication of this preliminary determination.

U.S. International Trade Commission Notification

In accordance with section 733(f) of the Act, Commerce will notify the U.S. International Trade Commission (ITC) of its preliminary determination of sales at LTFV. If the final determination is

¹⁸ See TDA's Letter, "TDA's Final Determination Extension Request," dated March 26, 2025; see also HSG's Letter, "Request for Extension of Final Determination," dated March 27, 2025.

¹⁹ See Petitioners' Letter, "Request for Postponement of Final Determinations," dated March 31, 2025.

affirmative, the ITC will determine before the later of 120 days after the date of this preliminary determination or 45 days after the date of this preliminary determination or 45 days after the final determination whether imports of the subject merchandise are materially injuring, or threaten material injury to, the U.S. industry.

Notification to Interested Parties

This determination is issued and published in accordance with sections 733(f) and 777(i)(1) of the Act and 19 CFR 351.205(c).

Dated: April 3, 2025.

Christopher Abbott,

Deputy Assistant Secretary for Policy and Negotiations, performing the non-exclusive functions and duties of the Assistant Secretary for Enforcement and Compliance.

Appendix I—Scope of the Investigation

The products covered by this investigation are certain flat-rolled steel products, either clad, plated, or coated with corrosion-resistant metals such as zinc, aluminum, or zinc-, aluminum-, nickel- or iron-based alloys, whether or not corrugated or painted, varnished, laminated, or coated with plastics or other non-metallic substances in addition to the metallic coating. The products covered include coils that have a width of 12.7 mm or greater, regardless of form of coil (e.g., in successively superimposed layers, spirally oscillating, etc.). The products covered also include products not in coils (e.g., in straight lengths) of a thickness less than 4.75 mm and a width that is 12.7 mm or greater and that measures at least 10 times the thickness. The products covered also include products not in coils (e.g., in straight lengths) of a thickness of 4.75 mm or more and a width exceeding 150 mm and measuring at least twice the thickness. The products described above may be rectangular, square, circular, or other shape and include products of either rectangular or non-rectangular cross-section where such cross-section is achieved subsequent to the rolling process, i.e., products which have been “worked after rolling” (e.g., products which have been beveled or rounded at the edges).

For purposes of the width and thickness requirements referenced above:

(1) Where the nominal and actual measurements vary, a product is within the scope if application of either the nominal or actual measurement would place it within the scope based on the definitions set forth above, and

(2) where the width and thickness vary for a specific product (e.g., the thickness of certain products with non-rectangular cross-section, the width of certain products with non-rectangular shape, etc.), the measurement at its greatest width or thickness applies.

Steel products included in the scope of these investigations are products in which: (1) iron predominates, by weight, over each of the other contained elements; and (2) the carbon content is 2 percent or less, by weight.

Subject merchandise also includes corrosion-resistant steel that has been further processed in a third country, including but not limited to annealing, tempering, painting, varnishing, trimming, cutting, punching and/or slitting or any other processing that would not otherwise remove the merchandise from the scope of the investigations if performed in the country of manufacture of the in-scope corrosion resistant steel.

All products that meet the written physical description are within the scope of these investigations unless specifically excluded. The following products are outside of and/or specifically excluded from the scope of this investigation:

- Flat-rolled steel products either plated or coated with tin, lead, chromium, chromium oxides, both tin and lead (“terne plate”) or both chromium and chromium oxides (“tin free steel”), whether or not painted, varnished or coated with plastics or other non-metallic substances in addition to the metallic coating;

- Clad products in straight lengths of 4.7625 mm or more in composite thickness and of a width which exceeds 150 mm and measures at least twice the thickness;

- Certain clad stainless flat-rolled products, which are three-layered corrosion-resistant carbon steel flat-rolled products less than 4.75 mm in composite thickness that consist of a carbon steel flat-rolled product clad on both sides with stainless steel in a 20%–60%–20% ratio; and

Also excluded from the scope of the antidumping duty investigation on corrosion resistant steel from Taiwan are any products covered by the existing antidumping duty order on corrosion-resistant steel from Taiwan. *See Certain Corrosion-Resistant Steel Products from India, Italy, the People’s Republic of China, the Republic of Korea and Taiwan: Amended Final Affirmative Antidumping Determination for India and Taiwan, and Antidumping Duty Orders*, 81 FR 48390 (July 25, 2016); *Corrosion-Resistant Steel Products from Taiwan: Notice of Third Amended Final Determination of Sales at Less Than Fair Value Pursuant to Court Decision and Partial Exclusion from Antidumping Duty Order*, 88 FR 58245 (August 25, 2023).

Also excluded from the scope of the antidumping duty investigation on corrosion-resistant steel from the United Arab Emirates and the antidumping duty and countervailing duty investigations on corrosion-resistant steel from the Socialist Republic of Vietnam are any products covered by the existing antidumping and countervailing duty orders on corrosion-resistant steel from the People’s Republic of China and the Republic of Korea and the antidumping duty order on corrosion-resistant steel from Taiwan. *See Certain Corrosion-Resistant Steel Products from India, Italy, the People’s Republic of China, the Republic of Korea and Taiwan: Amended Final Affirmative Antidumping Determination for India and Taiwan, and Antidumping Duty Orders*, 81 FR 48390 (July 25, 2016); *see also Certain Corrosion-Resistant Steel Products from India, Italy, Republic of Korea and the People’s Republic of China: Countervailing Duty Order*, 81 FR 48387 (July 25, 2016). This exclusion does

not apply to imports of corrosion-resistant steel that are entered, or withdrawn from warehouse, for consumption in the United States for which the relevant importer and exporter certifications have been completed and maintained and all other applicable certification requirements have been met such that the entry is entered into the United States as not subject to the antidumping and countervailing duty orders on corrosion-resistant steel from the People’s Republic of China, the antidumping and countervailing duty orders on corrosion-resistant steel from the Republic of Korea, or the antidumping duty order on corrosion-resistant steel from Taiwan.

The products subject to the investigation are currently classified in the Harmonized Tariff Schedule of the United States (HTSUS) under item numbers: 7210.30.0030, 7210.30.0060, 7210.41.0000, 7210.49.0030, 7210.49.0040, 7210.49.0045, 7210.49.0091, 7210.49.0095, 7210.61.0000, 7210.69.0000, 7210.70.6030, 7210.70.6060, 7210.70.6090, 7210.90.6000, 7210.90.9000, 7212.20.0000, 7212.30.1030, 7212.30.1090, 7212.30.3000, 7212.30.5000, 7212.40.1000, 7212.40.5000, 7212.50.0000, 7212.60.0000, 7225.91.0000, 7225.92.0000, 7226.99.0110, and 7226.99.0130.

The products subject to the investigation may also enter under the following HTSUS item numbers: 7210.90.1000, 7215.90.1000, 7215.90.3000, 7215.90.5000, 7217.20.1500, 7217.30.1530, 7217.30.1560, 7217.90.1000, 7217.90.5030, 7217.90.5060, 7217.90.5090, 7225.99.0090, 7226.99.0180, 7228.60.6000, 7228.60.8000, and 7229.90.1000.

The HTSUS subheadings above are provided for convenience and customs purposes only. The written description of the scope of the investigation is dispositive.

Appendix II—List of Topics Discussed in the Preliminary Decision Memorandum

- I. Summary
- II. Background
- III. Period of Investigation
- IV. Scope Comments
- V. Discussion of the Methodology
- VI. Currency Conversion
- VII. Adjustment Under Section 777A(f) of the Act
- VIII. Adjustments to Cash Deposit Rates for Export Subsidies in the Companion Countervailing Duty Investigation
- IX. Recommendation

[FR Doc. 2025–06142 Filed 4–9–25; 8:45 am]

BILLING CODE 3510–DS–P

DEPARTMENT OF COMMERCE

International Trade Administration

[A-602-812]

Certain Corrosion-Resistant Steel Products From Australia: Preliminary Affirmative Determination of Sales at Less Than Fair Value, Postponement of Final Determination, and Extension of Provisional Measures

AGENCY: Enforcement and Compliance, International Trade Administration, Department of Commerce.

SUMMARY: The U.S. Department of Commerce (Commerce) preliminarily determines that certain corrosion-resistant steel products (CORE) from Australia are being, or are likely to be, sold in the United States at less than fair value (LTFV). The period of investigation is July 1, 2023, through June 30, 2024. Interested parties are invited to comment on this preliminary determination.

DATES: Applicable April 10, 2025.

FOR FURTHER INFORMATION CONTACT: Krisha Hill, AD/CVD Operations, Office IV, Enforcement and Compliance, International Trade Administration, U.S. Department of Commerce, 1401 Constitution Avenue NW, Washington, DC 20230; telephone: (202) 482-4037.

SUPPLEMENTARY INFORMATION:**Background**

This preliminary determination is made in accordance with section 733(b) of the Tariff Act of 1930, as amended (the Act). Commerce published the notice of initiation of this investigation on October 2, 2024.¹ On January 28, 2025, Commerce postponed the preliminary determination of this investigation until April 3, 2025.² For a complete description of the events that followed the initiation of this investigation, see the Preliminary Decision Memorandum.³ A list of topics included in the Preliminary Decision

¹ See *Certain Corrosion-Resistant Steel Products from Australia, Brazil, Canada, Mexico, the Netherlands, South Africa, Taiwan, the Republic of Türkiye, the United Arab Emirates, and the Socialist Republic of Vietnam: Initiation of Less-Than-Fair-Value Investigations*, 89 FR 80196 (October 2, 2024) (*Initiation Notice*).

² See *Certain Corrosion-Resistant Steel Products from Australia, Brazil, Canada, Mexico, the Netherlands, South Africa, Taiwan, the Republic of Türkiye, the United Arab Emirates, and the Socialist Republic of Vietnam: Postponement of Preliminary Determinations in the Less-Than-Fair-Value Investigations*, 90 FR 8260 (January 28, 2025).

³ See Memorandum, “Decision Memorandum for the Preliminary Affirmative Determination in the Less-Than-Fair-Value Investigation of Certain Corrosion-Resistant Steel Products from Australia” dated concurrently with, and hereby adopted by, this notice (Preliminary Decision Memorandum).

Memorandum is included as Appendix II to this notice. The Preliminary Decision Memorandum is a public document and is on file electronically via Enforcement and Compliance’s Antidumping and Countervailing Duty Centralized Electronic Service System (ACCESS). ACCESS is available to registered users at <https://access.trade.gov>. In addition, a complete version of the Preliminary Decision Memorandum can be accessed directly at <https://access.trade.gov/public/FRNoticesListLayout.aspx>.

Scope of the Investigation

The product covered by this investigation is CORE from Australia. For a complete description of the scope of this investigation, see Appendix I.

Scope Comments

In accordance with the *Preamble* to Commerce’s regulations,⁴ in the *Initiation Notice*, Commerce set aside a period of time for parties to raise issues regarding product coverage (*i.e.*, scope).⁵ Certain interested parties commented on the scope of the investigation as it appeared in the *Initiation Notice*. For a summary of the product coverage comments and rebuttal responses submitted to the record of this investigation and accompanying discussion and analysis of all comments timely received, see the Preliminary Scope Decision Memorandum.⁶ Commerce is not preliminarily modifying the scope language as it appeared in the *Initiation Notice*. In the Preliminary Scope Decision Memorandum, Commerce established the deadline for parties to submit scope case and rebuttal briefs.⁷

Methodology

Commerce is conducting this investigation in accordance with section 731 of the Act. Commerce calculated constructed export prices in accordance with section 772(b) of the Act. Normal value is calculated in accordance with section 773 of the Act. For a full description of the methodology underlying the preliminary determination, see the Preliminary Decision Memorandum.

All-Others Rate

Sections 733(d)(1)(A)(ii) and 735(c)(5)(A) of the Act provide that in

⁴ See *Antidumping Duties; Countervailing Duties, Final Rule*, 62 FR 27296, 27323 (May 19, 1997) (*Preamble*).

⁵ See *Initiation Notice*, 89 FR at 80197.

⁶ See Memorandum, “Preliminary Scope Decision Memorandum,” dated concurrently with this notice (Preliminary Scope Decision Memorandum).

⁷ *Id.*

the preliminary determination, Commerce shall determine an estimated all-others rate for all exporters and producers not individually examined. This rate shall be an amount equal to the weighted average of the estimated weighted-average dumping margins established for exporters and producers individually investigated, excluding any zero and *de minimis* dumping margins, and any dumping margins determined entirely under section 776 of the Act.

Commerce calculated an individual estimated weighted-average dumping margin for BlueScope Steel Ltd./BlueScope Distribution Pty Ltd./Fielders Manufacturing Pty Ltd./Lysaght Building Solutions Pty Ltd. (BlueScope), the only individually examined exporter/producer in this investigation. Because the only individually calculated dumping margin is not zero, *de minimis*, or based entirely on facts otherwise available, Commerce assigned the estimated weighted-average dumping margin that it calculated for BlueScope to all other producers and exporters, pursuant to section 735(c)(5)(A) of the Act.

Preliminary Determination

Commerce preliminarily determines that the following estimated weighted-average dumping margins exist:

Exporter/producer	Estimated weighted-average dumping margin (percent)
BlueScope Steel Ltd./BlueScope Distribution Pty Ltd./Fielders Manufacturing Pty Ltd./Lysaght Building Solutions Pty Ltd	17.01
All Others	17.01

Suspension of Liquidation

In accordance with section 733(d)(2) of the Act, Commerce will direct U.S. Customs and Border Protection (CBP) to suspend liquidation of entries of subject merchandise, as described in Appendix I, entered, or withdrawn from warehouse, for consumption on or after the date of publication of this notice in the **Federal Register**. Further, pursuant to section 733(d)(1)(B) of the Act and 19 CFR 351.205(d), Commerce will instruct CBP to require a cash deposit equal to the estimated weighted-average dumping margin or the estimated all-others rate, as follows: (1) the cash deposit rate for the respondent listed above will be equal to the company-specific estimated weighted-average dumping margin determined in this preliminary determination; (2) if the

exporter is not a respondent identified above, but the producer is, then the cash deposit rate will be equal to the company-specific estimated weighted-average dumping margin established for that producer of the subject merchandise; and (3) the cash deposit rate for all other producers and exporters will be equal to the all-others estimated weighted-average dumping margin. These suspension of liquidation instructions will remain in effect until further notice.

Disclosure

Commerce intends to disclose its calculations and analysis performed to interested parties in this preliminary determination within five days of any public announcement or, if there is no public announcement, within five days of the date of publication of this notice in the **Federal Register**, in accordance with 19 CFR 351.224(b).

Consistent with 19 CFR 351.224(e), Commerce will analyze and, if appropriate, correct any timely allegations of significant ministerial errors by amending the preliminary determination. However, consistent with 19 CFR 351.224(d), Commerce will not consider incomplete allegations that do not address the significance standard under 19 CFR 351.224(g) following the preliminary determination. Instead, Commerce will address such allegations in the final determination together with issues raised in the case briefs or other written comments.

Verification

As provided in section 782(i)(1) of the Act, Commerce intends to verify the information that it relies upon in making its final determination.

Public Comment

Case briefs or other written comments, excluding scope comments, may be submitted to the Assistant Secretary for Enforcement and Compliance no later than seven days after the date on which the last verification report is issued in this investigation. Rebuttal briefs, limited to issues raised in the case briefs, may be filed not later than five days after the date for filing case briefs.⁸ Interested parties who submit case briefs or rebuttal briefs in this proceeding must submit: (1) a table of contents listing each issue; and (2) a table of authorities.⁹

⁸ See 19 CFR 351.309(d); see also *Administrative Protective Order, Service, and Other Procedures in Antidumping and Countervailing Duty Proceedings*, 88 FR 67069, 67077 (September 29, 2023) (*APO and Service Final Rule*).

⁹ See 19 CFR 351.309(c)(2) and (d)(2).

As provided under 19 CFR 351.309(c)(2) and (d)(2), in prior proceedings we have encouraged interested parties to provide an executive summary of their brief that should be limited to five pages total, including footnotes. In this investigation, we instead request that interested parties provide at the beginning of their briefs a public, executive summary for each issue raised in their briefs.¹⁰ Further, we request that interested parties limit their executive summary of each issue to no more than 450 words, not including citations. We intend to use the executive summaries as the basis for the comment summaries included in the issues and decision memorandum that will accompany the final determination in this investigation. We request that interested parties include footnotes for relevant citations in the executive summary of each issue. Note that Commerce has amended certain of its requirements pertaining to the service of documents in 19 CFR 351.303(f).¹¹

Pursuant to 19 CFR 351.310(c), interested parties who wish to request a hearing, limited to issues raised in the case and rebuttal briefs, must submit a written request to the Assistant Secretary for Enforcement and Compliance, U.S. Department of Commerce, within 30 days after the date of publication of this notice in the **Federal Register**. Requests should contain: (1) the party's name, address, and telephone number; (2) the number of participants and whether any participant is a foreign national; and (3) a list of the issues to be discussed. If a request for a hearing is made, Commerce intends to hold the hearing at a time and date to be determined. Parties should confirm by telephone the date, time, and location of the hearing two days before the scheduled date.

Postponement of Final Determination and Extension of Provisional Measures

Section 735(a)(2) of the Act provides that a final determination may be postponed until not later than 135 days after the date of the publication of the preliminary determination if, in the event of an affirmative preliminary determination, a request for such postponement is made by exporters who account for a significant proportion of exports of the subject merchandise, or in the event of a negative preliminary determination, a request for such postponement is made by the petitioner.

¹⁰ We use the term "issue" here to describe an argument that Commerce would normally address in a comment of the Issues and Decision Memorandum.

¹¹ See *APO and Service Final Rule*.

Section 351.210(e)(2) of Commerce's regulations requires that a request by exporters for postponement of the final determination be accompanied by a request for extension of provisional measures from a four-month period to a period not more than six months in duration.

On March 21, 2025, pursuant to 19 CFR 351.210(e), BlueScope requested that Commerce postpone the final determination and that provisional measures be extended to a period not to exceed six months.¹² In accordance with section 735(a)(2)(A) of the Act and 19 CFR 351.210(b)(2)(ii), because: (1) the preliminary determination is affirmative; (2) the requesting exporter accounts for a significant proportion of exports of the subject merchandise; and (3) no compelling reasons for denial exist, Commerce is postponing the final determination and extending the provisional measures from a four-month period to a period not greater than six months. Accordingly, Commerce will make its final determination no later than 135 days after the date of publication of this preliminary determination in the **Federal Register**.

U.S. International Trade Commission (ITC) Notification

In accordance with section 733(f) of the Act, Commerce will notify the ITC of its preliminary determination. If the final determination is affirmative, the ITC will determine before the later of 120 days after the date of this preliminary determination or 45 days after the final determination whether these imports are materially injuring, or threaten material injury to, the U.S. industry.

Notification to Interested Parties

This determination is issued and published in accordance with sections 733(f) and 777(i)(1) of the Act, and 19 CFR 351.205(c).

Dated: April 3, 2025.

Christopher Abbott,

Deputy Assistant Secretary for Policy and Negotiations, performing the non-exclusive functions and duties of the Assistant Secretary for Enforcement and Compliance.

Appendix I

Scope of the Investigation

The products covered by the investigation are certain flat-rolled steel products, either clad, plated, or coated with corrosion-resistant metals such as zinc, aluminum, or zinc-, aluminum-, nickel- or iron-based alloys, whether or not corrugated or painted, varnished, laminated, or coated with plastics

¹² See BlueScope's Letter, "BlueScope's Request for Postponement of Final Determination," dated March 21, 2025.

or other non-metallic substances in addition to the metallic coating. The products covered include coils that have a width of 12.7 mm or greater, regardless of form of coil (e.g., in successively superimposed layers, spirally oscillating, etc.). The products covered also include products not in coils (e.g., in straight lengths) of a thickness less than 4.75 mm and a width that is 12.7 mm or greater and that measures at least 10 times the thickness. The products covered also include products not in coils (e.g., in straight lengths) of a thickness of 4.75 mm or more and a width exceeding 150 mm and measuring at least twice the thickness. The products described above may be rectangular, square, circular, or other shape and include products of either rectangular or non-rectangular cross-section where such cross-section is achieved subsequent to the rolling process, i.e., products which have been “worked after rolling” (e.g., products which have been beveled or rounded at the edges).

For purposes of the width and thickness requirements referenced above:

(1) Where the nominal and actual measurements vary, a product is within the scope if application of either the nominal or actual measurement would place it within the scope based on the definitions set forth above, and

(2) where the width and thickness vary for a specific product (e.g., the thickness of certain products with non-rectangular cross-section, the width of certain products with non-rectangular shape, etc.), the measurement at its greatest width or thickness applies.

Steel products included in the scope of the investigation are products in which: (1) iron predominates, by weight, over each of the other contained elements; and (2) the carbon content is 2 percent or less, by weight.

Subject merchandise also includes corrosion-resistant steel that has been further processed in a third country, including but not limited to annealing, tempering, painting, varnishing, trimming, cutting, punching and/or slitting or any other processing that would not otherwise remove the merchandise from the scope of the investigation if performed in the country of manufacture of the in-scope corrosion resistant steel.

All products that meet the written physical description are within the scope of the investigation unless specifically excluded. The following products are outside of and/or specifically excluded from the scope of the investigation:

- Flat-rolled steel products either plated or coated with tin, lead, chromium, chromium oxides, both tin and lead (“terne plate”) or both chromium and chromium oxides (“tin free steel”), whether or not painted, varnished or coated with plastics or other non-metallic substances in addition to the metallic coating;

- Clad products in straight lengths of 4.7625 mm or more in composite thickness and of a width which exceeds 150 mm and measures at least twice the thickness;

- Certain clad stainless flat-rolled products, which are three-layered corrosion-resistant carbon steel flat-rolled products less than 4.75 mm in composite thickness that consist of a carbon steel flat-rolled product

clad on both sides with stainless steel in a 20%–60%–20% ratio; and

Also excluded from the scope of the antidumping duty investigation on corrosion resistant steel from Taiwan are any products covered by the existing antidumping duty order on corrosion-resistant steel from Taiwan. *See Certain Corrosion-Resistant Steel Products from India, Italy, the People’s Republic of China, the Republic of Korea and Taiwan: Amended Final Affirmative Antidumping Determination for India and Taiwan, and Antidumping Duty Orders*, 81FR 48390 (July 25, 2016); *Corrosion-Resistant Steel Products from Taiwan: Notice of Third Amended Final Determination of Sales at Less Than Fair Value Pursuant to Court Decision and Partial Exclusion from Antidumping Duty Order*, 88 FR 58245 (August 25, 2023).

Also excluded from the scope of the antidumping duty investigation on corrosion-resistant steel from the United Arab Emirates and the antidumping duty and countervailing duty investigations on corrosion-resistant steel from the Socialist Republic of Vietnam are any products covered by the existing antidumping and countervailing duty orders on corrosion-resistant steel from the People’s Republic of China and the Republic of Korea and the antidumping duty order on corrosion-resistant steel from Taiwan. *See Certain Corrosion-Resistant Steel Products from India, Italy, the People’s Republic of China, the Republic of Korea and Taiwan: Amended Final Affirmative Antidumping Determination for India and Taiwan, and Antidumping Duty Orders*, 81 FR 48390 (July 25, 2016); *see also Certain Corrosion-Resistant Steel Products from India, Italy, Republic of Korea and the People’s Republic of China: Countervailing Duty Order*, 81 FR 48387 (July 25, 2016). This exclusion does not apply to imports of corrosion-resistant steel that are entered, or withdrawn from warehouse, for consumption in the United States for which the relevant importer and exporter certifications have been completed and maintained and all other applicable certification requirements have been met such that the entry is entered into the United States as not subject to the antidumping and countervailing duty orders on corrosion-resistant steel from the People’s Republic of China, the antidumping and countervailing duty orders on corrosion-resistant steel from the Republic of Korea, or the antidumping duty order on corrosion-resistant steel from Taiwan.

The products subject to the investigation are currently classified in the Harmonized Tariff Schedule of the United States (HTSUS) under item numbers: 7210.30.0030, 7210.30.0060, 7210.41.0000, 7210.49.0030, 7210.49.0040, 7210.49.0045, 7210.49.0091, 7210.49.0095, 7210.61.0000, 7210.69.0000, 7210.70.6030, 7210.70.6060, 7210.70.6090, 7210.90.6000, 7210.90.9000, 7212.20.0000, 7212.30.1030, 7212.30.1090, 7212.30.3000, 7212.30.5000, 7212.40.1000, 7212.40.5000, 7212.50.0000, 7212.60.0000, 7225.91.0000, 7225.92.0000, 7226.99.0110, and 7226.99.0130.

The products subject to the investigation may also enter under the following HTSUS item numbers: 7210.90.1000, 7215.90.1000,

7215.90.3000, 7215.90.5000, 7217.20.1500, 7217.30.1530, 7217.30.1560, 7217.90.1000, 7217.90.5030, 7217.90.5060, 7217.90.5090, 7225.99.0090, 7226.99.0180, 7228.60.6000, 7228.60.8000, and 7229.90.1000.

The HTSUS subheadings above are provided for convenience and customs purposes only. The written description of the scope of the investigation is dispositive.

Appendix II

List of Topics Discussed in the Preliminary Decision Memorandum

- I. Summary
- II. Background
- III. Period of Investigation
- IV. Scope Comments
- V. Affiliation and Single Entity Treatment
- VI. Discussion of the Methodology
- VII. Currency Conversion
- VIII. Recommendation

[FR Doc. 2025–06133 Filed 4–9–25; 8:45 am]

BILLING CODE 3510–DS–P

DEPARTMENT OF COMMERCE

International Trade Administration

[A–201–863]

Certain Corrosion-Resistant Steel Products From Mexico: Preliminary Affirmative Determination of Sales at Less Than Fair Value, Postponement of Final Determination, and Extension of Provisional Measures

AGENCY: Enforcement and Compliance, International Trade Administration, Department of Commerce.

SUMMARY: The U.S. Department of Commerce (Commerce) preliminarily determines that certain corrosion-resistant steel products (CORE) from Mexico are being, or are likely to be, sold in the United States at less than fair value (LTFV). The period of investigation is July 1, 2023, through June 30, 2024. Interested parties are invited to comment on this preliminary determination.

DATES: Applicable April 10, 2025.

FOR FURTHER INFORMATION CONTACT: Katerina Katsiadis or Brian Smith, AD/CVD Operations, Office VIII, Enforcement and Compliance, International Trade Administration, U.S. Department of Commerce, 1401 Constitution Avenue NW, Washington, DC 20230; telephone: (202) 482–4929 or (202) 482–1766, respectively.

SUPPLEMENTARY INFORMATION:

Background

This preliminary determination is made in accordance with section 733(b) of the Tariff Act of 1930, as amended (the Act). Commerce published the notice of initiation of this investigation

on October 2, 2024.¹ On January 28, 2025, Commerce postponed the preliminary determination of this investigation until April 3, 2025.² For a complete description of the events that followed the initiation of this investigation, *see* the Preliminary Decision Memorandum.³ A list of topics included in the Preliminary Decision Memorandum is included as Appendix II to this notice. The Preliminary Decision Memorandum is a public document and is on file electronically via Enforcement and Compliance’s Antidumping and Countervailing Duty Centralized Electronic Service System (ACCESS). ACCESS is available to registered users at <https://access.trade.gov>. In addition, a complete version of the Preliminary Decision Memorandum can be accessed directly at <https://access.trade.gov/public/FRNoticesListLayout.aspx>.

Scope of the Investigation

The product covered by this investigation is CORE from Mexico. For a complete description of the scope of this investigation, *see* Appendix I.

Scope Comments

In accordance with the *Preamble* to Commerce’s regulations,⁴ in the *Initiation Notice*, Commerce set aside a period of time for parties to raise issues regarding product coverage (*i.e.*, scope).⁵

Certain interested parties commented on the scope of the investigation as it appeared in the *Initiation Notice*. For a summary of the product coverage comments and rebuttal responses submitted to the record for this investigation and accompanying discussion and analysis of all comments timely received, *see* the Preliminary Scope Decision Memorandum.⁶ Commerce is not preliminarily modifying the scope language as it appeared in the *Initiation Notice*. In the Preliminary Scope Decision Memorandum, Commerce established the deadline for parties to submit scope case and rebuttal briefs.⁷

Methodology

Commerce is conducting this investigation in accordance with section 731 of the Act. Commerce calculated export prices for Galvasid S.A. de C.V. and Perfiles LM, S.A. de C.V. (collectively, Galvasid/Perfiles)⁸ in accordance with section 772(a) of the Act and calculated constructed export prices for Ternium Mexico, S.A. de C.V. and Tenigal, S.de R.L. de C.V. (collectively, Ternium Mexico/Tenegal)⁹ in accordance with section 772(b) of the Act. Normal value is calculated in accordance with section 773 of the Act. For a full description of the methodology underlying the

preliminary determination, *see* the Preliminary Decision Memorandum.

All-Others Rate

Sections 733(d)(1)(ii) and 735(c)(5)(A) of the Act provide that in the preliminary determination Commerce shall determine an estimated all-others rate for all exporters and producers not individually examined. This rate shall be an amount equal to the weighted average of the estimated weighted-average dumping margins established for exporters and producers individually investigated, excluding any zero and *de minimis* margins, and any margins determined entirely under section 776 of the Act.

In this investigation, Commerce calculated estimated weighted-average dumping margins for Galvasid/Perfiles and Ternium Mexico/Tenegal that are not zero, *de minimis*, or based entirely on facts otherwise available. Commerce calculated the all-others rate using a weighted average of the estimated weighted-average dumping margins calculated for the examined respondents using each company’s publicly-ranged values for the merchandise under consideration.¹⁰

Preliminary Determination

Commerce preliminarily determines that the following estimated weighted-average dumping margins exist:

Exporter/producer	Estimated weighted-average dumping margin (percent)	Cash deposit rate (adjusted for subsidy offset(s)) (percent)
Galvasid S.A. de C.V./Perfiles LM, S.A. de C.V.	14.43	¹¹ 14.43
Ternium Mexico S.A. de C.V./Tenigal, S.de R.L. de C.V.	3.43	¹² 1.87
All Others	7.03	5.47

¹ *See Certain Corrosion-Resistant Steel Products From Australia, Brazil, Canada, Mexico, the Netherlands, South Africa, Taiwan, the Republic of Türkiye, the United Arab Emirates, and the Socialist Republic of Vietnam: Initiation of Less-Than-Fair-Value Investigations*, 89 FR 80196 (October 2, 2024) (*Initiation Notice*).

² *See Certain Corrosion-Resistant Steel Products From Australia, Brazil, Canada, Mexico, the Netherlands, South Africa, Taiwan, the Republic of Türkiye, the United Arab Emirates, and the Socialist Republic of Vietnam: Postponement of Preliminary Determinations in the Less-Than-Fair-Value Investigations*, 90 FR 8260 (January 28, 2025).

³ *See* Memorandum, “Decision Memorandum for the Preliminary Affirmative Determination in the Less-Than-Fair-Value Investigation of Certain Corrosion Resistant Steel Products from Mexico” dated concurrently with, and hereby adopted by, this notice (Preliminary Decision Memorandum).

⁴ *See Antidumping Duties; Countervailing Duties, Final Rule*, 62 FR 27296, 27323 (May 19, 1997).

⁵ *See Initiation Notice*, 89 FR at 80197.

⁶ *See* Memorandum, “*Certain Corrosion-Resistant Steel Products From Australia, Brazil, Canada,*

Mexico, the Netherlands, South Africa, Taiwan, the Republic of Türkiye, the United Arab Emirates, and the Socialist Republic of Vietnam: Scope Comments Decision Memorandum for the Preliminary Determination,” dated concurrently with this Preliminary Determination (Preliminary Scope Decision Memorandum).

⁷ *Id.*

⁸ Commerce preliminarily determines that Galvasid and Perfiles are a single entity. *See* Preliminary Decision Memorandum.

⁹ Commerce preliminarily determines that Ternium Mexico and Tenigal are a single entity. *See* Preliminary Decision Memorandum.

¹⁰ *See* Memorandum, “Calculation of the All-Others Rate,” dated concurrently with this notice. With two respondents under examination, Commerce normally calculates: (A) a weighted-average of the estimated weighted-average dumping margins calculated for the examined respondents; (B) a simple average of the estimated weighted-average dumping margins calculated for the examined respondents; and (C) a weighted-average of the estimated weighted-average dumping margins calculated for the examined respondents using each

company’s publicly-ranged U.S. sales values for the merchandise under consideration. Commerce then compares (B) and (C) to (A) and selects the rate closest to (A) as the most appropriate rate for all other producers and exporters. *See, e.g., Ball Bearings and Parts Thereof from France, Germany, Italy, Japan, and the United Kingdom: Final Results of Antidumping Duty Administrative Reviews, Final Results of Changed-Circumstances Review, and Revocation of an Order in Part*, 75 FR 53661, 53662 (September 1, 2010), and accompanying Issues and Decision Memorandum at Comment 1. As complete publicly ranged sales data were available, Commerce based the all-others rate on the publicly ranged sales data of the mandatory respondents.

¹¹ *See Certain Corrosion-Resistant Steel Products from Mexico: Preliminary Affirmative Countervailing Duty Determination, and Alignment of Final Determination With Final Antidumping Duty Determination*, 90 FR 9226 (February 10, 2025), and accompanying Preliminary Decision Memorandum at 9–10.

¹² *Id.*

Suspension of Liquidation

In accordance with section 733(d)(2) of the Act, Commerce will direct U.S. Customs and Border Protection (CBP) to suspend liquidation of entries of subject merchandise, as described in Appendix I, entered, or withdrawn from warehouse, for consumption on or after the date of publication of this notice in the **Federal Register**. Further, pursuant to section 733(d)(1)(B) of the Act and 19 CFR 351.205(d), Commerce will instruct CBP to require a cash deposit equal to the estimated weighted-average dumping margin or the estimated all-others rate, as follows: (1) the cash deposit rate for the respondents listed above will be equal to the company-specific estimated weighted-average dumping margins determined in this preliminary determination; (2) if the exporter is not a respondent identified above, but the producer is, then the cash deposit rate will be equal to the company-specific estimated weighted-average dumping margin established for that producer of the subject merchandise; and (3) the cash deposit rate for all other producers and exporters will be equal to the all-others estimated weighted-average dumping margin.

To determine the cash deposit rates, Commerce normally adjusts the estimated weighted-average dumping margin by the amount of domestic subsidy pass-through and export subsidies determined in a companion countervailing duty (CVD) proceeding when CVD provisional measures are in effect. Accordingly, where Commerce has made a preliminary affirmative determination for domestic subsidy pass-through or export subsidies, Commerce has offset the calculated estimated weighted-average dumping margin by the appropriate rate(s). Any such adjusted cash deposit rate may be found in the “Preliminary Determination” section above.

Should provisional measures in the companion CVD investigation expire prior to the expiration of provisional measures in this LTFV investigation, Commerce will direct CBP to begin collecting cash deposits at a rate equal to the estimated weighted-average dumping margins calculated in this preliminary determination unadjusted for the passed-through domestic subsidies or for export subsidies at the time the CVD provisional measures expire.

These suspension of liquidation instructions will remain in effect until further notice.

Disclosure

Commerce intends to disclose to interested parties the calculations performed in connection with this preliminary determination within five days of its public announcement or, if there is no public announcement, within five days of the date of publication of this notice in accordance with 19 CFR 351.224(b).

Consistent with 19 CFR 351.224(e), Commerce will analyze and, if appropriate, correct any timely allegations of significant ministerial errors by amending the preliminary determination. However, consistent with 19 CFR 351.224(d), Commerce will not consider incomplete allegations that do not address the significance standard under 19 CFR 351.224(g) following the preliminary determination. Instead, Commerce will address such allegations in the final determination together with issues raised in the case briefs or other written comments.

Verification

As provided in section 782(i)(1) of the Act, Commerce intends to verify the information relied upon in making its final determination.

Public Comment

Case briefs or other written comments, excluding scope comments, may be submitted to the Assistant Secretary for Enforcement and Compliance no later than seven days after the date on which the last verification report is issued in this investigation.¹³ Rebuttal briefs, limited to issues raised in the case briefs, may be filed not later than five days after the date for filing case briefs.¹⁴ Interested parties who submit case briefs or rebuttal briefs in this proceeding must submit: (1) a table of contents listing each issue; and (2) a table of authorities.¹⁵

As provided under 19 CFR 351.309(c)(2) and (d)(2), in prior proceedings we have encouraged interested parties to provide an executive summary of their brief that should be limited to five pages total, including footnotes. In this investigation, we instead request that interested parties provide at the beginning of their briefs a public, executive summary for each issue raised

in their briefs.¹⁶ Further, we request that interested parties limit their executive summary of each issue to no more than 450 words, not including citations. We intend to use the executive summaries as the basis of the comment summaries included in the issues and decision memorandum that will accompany the final determination in this investigation. We request that interested parties include footnotes for relevant citations in the executive summary of each issue. Note that Commerce has amended certain of its requirements pertaining to the service of documents in 19 CFR 351.303(f).¹⁷

Pursuant to 19 CFR 351.310(c), interested parties who wish to request a hearing, limited to issues raised in the case and rebuttal briefs, must submit a written request to the Assistant Secretary for Enforcement and Compliance, U.S. Department of Commerce, within 30 days after the date of publication of this notice. Requests should contain: (1) the party's name, address, and telephone number; (2) the number of participants and whether any participant is a foreign national; and (3) a list of the issues to be discussed. If a request for a hearing is made, Commerce intends to hold the hearing at a date and time to be determined. Parties should confirm by telephone the date, time, and location of the hearing two days before the scheduled date.

Postponement of Final Determination and Extension of Provisional Measures

Section 735(a)(2) of the Act provides that a final determination may be postponed until not later than 135 days after the date of the publication of the preliminary determination if, in the event of an affirmative preliminary determination, a request for such postponement is made by exporters who account for a significant proportion of exports of the subject merchandise, or in the event of a negative preliminary determination, a request for such postponement is made by the petitioners. Pursuant to 19 CFR 351.210(e)(2), Commerce requires that requests by respondents for postponement of a final antidumping determination be accompanied by a request for extension of provisional measures from a four-month period to a period not more than six months in duration.

On March 10, 2025, pursuant to 19 CFR 351.210(e), Ternium Mexico/Tenigal requested that Commerce

¹³ See 19 CFR 351.309(c)(1)(i); see also 19 CFR 351.303 (for general filing requirements).

¹⁴ See 19 CFR 351.309(d); see also *Administrative Protective Order, Service, and Other Procedures in Antidumping and Countervailing Duty Proceedings*, 88 FR 67069, 67077 (September 29, 2023) (*APO and Service Final Rule*).

¹⁵ See 19 CFR 351.309(c)(2) and (d)(2).

¹⁶ We use the term “issue” here to describe an argument that Commerce would normally address in a comment of the Issues and Decision Memorandum.

¹⁷ See *APO and Service Final Rule*.

postpone the final determination and that provisional measures be extended to a period not to exceed six months.¹⁸ In accordance with section 735(a)(2)(A) of the Act and 19 CFR 351.210(b)(2)(ii), because: (1) the preliminary determination is affirmative; (2) the requesting exporter accounts for a significant proportion of exports of the subject merchandise; and (3) no compelling reasons for denial exist, Commerce is postponing the final determination and extending the provisional measures from a four-month period to a period not greater than six months. Accordingly, Commerce will make its final determination no later than 135 days after the date of publication of this preliminary determination.

U.S. International Trade Commission (ITC) Notification

In accordance with section 733(f) of the Act, Commerce will notify the ITC of its preliminary determination. If the final determination is affirmative, the ITC will determine before the later of 120 days after the date of this preliminary determination or 45 days after the final determination whether imports of CORE from Mexico are materially injuring, or threaten material injury to, the U.S. industry.

Notification to Interested Parties

This determination is issued and published in accordance with sections 733(f) and 777(i)(1) of the Act, and 19 CFR 351.205(c).

Dated: April 3, 2025.

Christopher Abbott,

Deputy Assistant Secretary for Policy and Negotiations, performing the non-exclusive functions and duties of the Assistant Secretary for Enforcement and Compliance.

Appendix I

Scope of the Investigation

The products covered by this investigation are certain flat-rolled steel products, either clad, plated, or coated with corrosion-resistant metals such as zinc, aluminum, or zinc-, aluminum-, nickel- or iron-based alloys, whether or not corrugated or painted, varnished, laminated, or coated with plastics or other non-metallic substances in addition to the metallic coating. The products covered include coils that have a width of 12.7 mm or greater, regardless of form of coil (*e.g.*, in successively superimposed layers, spirally oscillating, *etc.*). The products covered also include products not in coils (*e.g.*, in straight lengths) of a thickness less than 4.75 mm and a width that is 12.7 mm or greater and that measures at least 10 times the thickness. The products covered also include products not

in coils (*e.g.*, in straight lengths) of a thickness of 4.75 mm or more and a width exceeding 150 mm and measuring at least twice the thickness. The products described above may be rectangular, square, circular, or other shape and include products of either rectangular or non-rectangular cross-section where such cross-section is achieved subsequent to the rolling process, *i.e.*, products which have been “worked after rolling” (*e.g.*, products which have been beveled or rounded at the edges).

For purposes of the width and thickness requirements referenced above:

(1) Where the nominal and actual measurements vary, a product is within the scope if application of either the nominal or actual measurement would place it within the scope based on the definitions set forth above, and

(2) where the width and thickness vary for a specific product (*e.g.*, the thickness of certain products with non-rectangular cross-section, the width of certain products with non-rectangular shape, *etc.*), the measurement at its greatest width or thickness applies.

Steel products included in the scope of this investigation are products in which: (1) iron predominates, by weight, over each of the other contained elements; and (2) the carbon content is 2 percent or less, by weight.

Subject merchandise also includes corrosion-resistant steel that has been further processed in a third country, including but not limited to annealing, tempering, painting, varnishing, trimming, cutting, punching and/or slitting or any other processing that would not otherwise remove the merchandise from the scope of the investigation if performed in the country of manufacture of the in-scope corrosion resistant steel.

All products that meet the written physical description are within the scope of this investigation unless specifically excluded. The following products are outside of and/or specifically excluded from the scope of this investigation:

- Flat-rolled steel products either plated or coated with tin, lead, chromium, chromium oxides, both tin and lead (“terne plate”) or both chromium and chromium oxides (“tin free steel”), whether or not painted, varnished or coated with plastics or other nonmetallic substances in addition to the metallic coating;

- Clad products in straight lengths of 4.7625 mm or more in composite thickness and of a width which exceeds 150 mm and measures at least twice the thickness;

- Certain clad stainless flat-rolled products, which are three-layered corrosion-resistant carbon steel flat-rolled products less than 4.75 mm in composite thickness that consist of a carbon steel flat-rolled product clad on both sides with stainless steel in a 20%–60%–20% ratio.

The products subject to this investigation are currently classified in the Harmonized Tariff Schedule of the United States (HTSUS) under item numbers: 7210.30.0030, 7210.30.0060, 7210.41.0000, 7210.49.0030, 7210.49.0040, 7210.49.0045, 7210.49.0091, 7210.49.0095, 7210.61.0000, 7210.69.0000, 7210.70.6030, 7210.70.6060, 7210.70.6090, 7210.90.6000, 7210.90.9000, 7212.20.0000,

7212.30.1030, 7212.30.1090, 7212.30.3000, 7212.30.5000, 7212.40.1000, 7212.40.5000, 7212.50.0000, 7212.60.0000, 7225.91.0000, 7225.92.0000, 7226.99.0110, and 7226.99.0130.

The products subject to this investigation may also enter under the following HTSUS item numbers: 7210.90.1000, 7215.90.1000, 7215.90.3000, 7215.90.5000, 7217.20.1500, 7217.30.1530, 7217.30.1560, 7217.90.1000, 7217.90.5030, 7217.90.5060, 7217.90.5090, 7225.99.0090, 7226.99.0180, 7228.60.6000, 7228.60.8000, and 7229.90.1000.

The HTSUS subheadings above are provided for convenience and customs purposes only. The written description of the scope of this investigation is dispositive.

Appendix II

List of Topics Discussed in the Preliminary Decision Memorandum

- I. Summary
- II. Background
- III. Period of Investigation
- IV. Scope Comments
- V. Affiliation and Single Entity Treatment
- VI. Discussion of the Methodology
- VII. Currency Conversion
- VIII. Adjustments to Cash Deposit Rates for Export Subsidies in the Companion Countervailing Duty Investigation
- IX. Recommendation

[FR Doc. 2025–06136 Filed 4–9–25; 8:45 am]

BILLING CODE 3510–DS–P

DEPARTMENT OF COMMERCE

International Trade Administration

[A–421–818]

Certain Corrosion-Resistant Steel Products From the Netherlands: Preliminary Affirmative Determination of Sales at Less Than Fair Value, Postponement of Final Determination, and Extension of Provisional Measures

AGENCY: Enforcement and Compliance, International Trade Administration, Department of Commerce.

SUMMARY: The U.S. Department of Commerce (Commerce) preliminarily determines that certain corrosion-resistant steel products (CORE) from the Netherlands are being, or are likely to be, sold in the United States at less than fair value (LTFV). The period of investigation (POI) is July 1, 2023, through June 30, 2024. Interested parties are invited to comment on this preliminary determination.

DATES: Applicable April 10, 2025.

FOR FURTHER INFORMATION CONTACT: Rachel Jennings or Miranda Bourdeau, AD/CVD Operations, Office V, Enforcement and Compliance, International Trade Administration, U.S. Department of Commerce, 1401 Constitution Avenue NW, Washington,

¹⁸ See Ternium Mexico’s Letter, “Request to Extend Final Determination,” dated March 10, 2025.

DC 20230; telephone: (202) 482–1110 or (202) 482–2021, respectively.

SUPPLEMENTARY INFORMATION:

Background

This preliminary determination is made in accordance with section 733(b) of the Tariff Act of 1930, as amended (the Act). Commerce published the notice of initiation of this investigation on October 2, 2024.¹ On January 28, 2025, Commerce postponed the preliminary determination of this investigation until April 3, 2025.² For a complete description of the events that followed the initiation of this investigation, see the Preliminary Decision Memorandum.³ A list of topics included in the Preliminary Decision Memorandum is included as Appendix II to this notice. The Preliminary Decision Memorandum is a public document and is on file electronically via Enforcement and Compliance's Antidumping and Countervailing Duty Centralized Electronic Service System (ACCESS). ACCESS is available to registered users at <https://access.trade.gov>. In addition, a complete version of the Preliminary Decision Memorandum can be accessed directly at <https://access.trade.gov/public/FRNoticesListLayout.aspx>.

Scope of the Investigation

The products covered by this investigation are CORE from the Netherlands. For a complete description of the scope of this investigation, see Appendix I.

Scope Comments

In accordance with the *Preamble* to Commerce's regulations,⁴ in the *Initiation Notice*, Commerce set aside a period of time for parties to raise issues regarding product coverage (*i.e.*, scope).⁵

¹ See *Certain Corrosion-Resistant Steel Products from Australia, Brazil, Canada, Mexico, the Netherlands, South Africa, Taiwan, the Republic of Türkiye, the United Arab Emirates, and the Socialist Republic of Vietnam: Initiation of Less-Than-Fair-Value Investigations*, 89 FR 80196 (October 2, 2024) (*Initiation Notice*).

² See *Certain Corrosion-Resistant Steel Products from Australia, Brazil, Canada, Mexico, the Netherlands, South Africa, Taiwan, the Republic of Türkiye, the United Arab Emirates, and the Socialist Republic of Vietnam: Postponement of Preliminary Determinations of Antidumping Duty Investigations*, 90 FR 8260 (January 28, 2025).

³ See Memorandum, "Decision Memorandum for the Preliminary Affirmative Determination in the Less-Than-Fair-Value Investigation of Certain Corrosion-Resistant Steel Products from the Netherlands" dated concurrently with, and hereby adopted by, this notice (Preliminary Decision Memorandum).

⁴ See *Antidumping Duties; Countervailing Duties, Final Rule*, 62 FR 27296, 27323 (May 19, 1997) (*Preamble*).

⁵ See *Initiation Notice*, 89 FR at 80197.

Certain interested parties commented on the scope of the investigation as it appeared in the *Initiation Notice*. For a summary of the product coverage comments and rebuttal responses submitted to the record for this investigation and accompanying discussion and analysis of all comments timely received, see the Preliminary Scope Decision Memorandum.⁶ Commerce is not preliminarily modifying the scope language as it appeared in the *Initiation Notice*. See the scope in Appendix I to this notice. In the Preliminary Scope Decision Memorandum, Commerce established the deadline for parties to submit scope case and rebuttal briefs.⁷

Methodology

Commerce is conducting this investigation in accordance with section 731 of the Act. Commerce has calculated export prices in accordance with section 772(a) of the Act. Constructed export prices have been calculated in accordance with section 772(b) of the Act. Normal value is calculated in accordance with section 773 of the Act. In addition, Commerce has relied on partial adverse facts available under sections 776(a) and (b) of the Act for Tata-Wuppermann.⁸ For a full description of the methodology underlying the preliminary determination, see the Preliminary Decision Memorandum.

All-Others Rate

Sections 733(d)(1)(A)(ii) and 735(c)(5)(A) of the Act provide that in the preliminary determination Commerce shall determine an estimated all-others rate for all exporters and producers not individually examined. This rate shall be an amount equal to the weighted average of the estimated weighted-average dumping margins established for exporters and producers individually investigated, excluding any zero and *de minimis* margins, and any margins determined entirely under section 776 of the Act.

Commerce calculated an individual estimated weighted-average dumping

⁶ See Memorandum, "Preliminary Scope Decision Memorandum," dated concurrently with this notice (Preliminary Scope Decision Memorandum).

⁷ *Id.*

⁸ Commerce preliminarily determines that Tata Steel IJmuiden BV (Tata), Wuppermann Staal Nederland BV (Wuppermann), and Service Center Maastricht BV (Multisteel), (collectively, Tata-Wuppermann) are a single entity. See Preliminary Decision Memorandum; see also Memorandum, "Preliminary Affiliation and Collapsing Memorandum for Tata Steel IJmuiden BV and Wuppermann Staal Nederland BV," dated concurrently with this memorandum (Tata-Wuppermann Collapsing Memorandum).

margin for Tata-Wuppermann,⁹ the only individually examined exporter/producer in this investigation. Because the only individually calculated dumping margin is not zero, *de minimis*, or based entirely on facts otherwise available, the estimated weighted-average dumping margin calculated for Tata-Wuppermann is the margin assigned to all other producers and exporters, pursuant to section 735(c)(5)(A) of the Act.

Preliminary Determination

Commerce preliminarily determines that the following estimated weighted-average dumping margins exist:

Exporter/producer	Weighted-average dumping margin (percent)
Tata Steel IJmuiden BV/ Wuppermann Staal Nederland BV/Service Center Maastricht BV	22.59
All Others	22.59

Suspension of Liquidation

In accordance with section 733(d)(2) of the Act, Commerce will direct U.S. Customs and Border Protection (CBP) to suspend liquidation of entries of subject merchandise, as described in Appendix I, entered, or withdrawn from warehouse, for consumption on or after the date of publication of this notice in the **Federal Register**. Further, pursuant to section 733(d)(1)(B) of the Act and 19 CFR 351.205(d), Commerce will instruct CBP to require a cash deposit equal to the estimated weighted-average dumping margin or the estimated all-others rate, as follows: (1) The cash deposit rate for the respondent listed above will be equal to the company-specific estimated weighted-average dumping margin determined in this preliminary determination; (2) if the exporter is not a respondent identified above, but the producer is, then the cash deposit rate will be equal to the company-specific estimated weighted-average dumping margin established for that producer of the subject merchandise; and (3) the cash deposit rate for all other producers and exporters will be equal to the all-others estimated weighted-average dumping margin.

⁹ Commerce preliminarily determines that Tata Steel IJmuiden BV (Tata) and Wuppermann Staal Nederland BV (Wuppermann) (collectively, Tata-Wuppermann) are a single entity. See Preliminary Decision Memorandum.

Disclosure

Commerce intends to disclose its calculations and analysis performed to interested parties in this preliminary determination within five days of any public announcement or, if there is no public announcement, within five days of the date of publication of this notice in accordance with 19 CFR 351.224(b).

Consistent with 19 CFR 351.224(e), Commerce will analyze and, if appropriate, correct any timely allegations of significant ministerial errors by amending the preliminary determination. However, consistent with 19 CFR 351.224(d), Commerce will not consider incomplete allegations that do not address the significance standard under 19 CFR 351.224(g) following the preliminary determination. Instead, Commerce will address such allegations in the final determination together with issues raised in the case briefs or other written comments.

Verification

As provided in section 782(i)(1) of the Act, Commerce intends to verify the information relied upon in making its final determination.

Public Comment

Case briefs or other written comments, excluding scope comments, may be submitted to the Assistant Secretary for Enforcement and Compliance no later than seven days after the date on which the last verification report is issued in this investigation. Rebuttal briefs, limited to issues raised in the case briefs, may be filed not later than five days after the date for filing case briefs.¹⁰ Interested parties who submit case briefs or rebuttal briefs in this proceeding must submit: (1) a table of contents listing each issue; and (2) a table of authorities.¹¹

As provided under 19 CFR 351.309(c)(2) and (d)(2), in prior proceedings we have encouraged interested parties to provide an executive summary of their briefs that should be limited to five pages total, including footnotes. In this investigation, we instead request that interested parties provide at the beginning of their briefs a public, executive summary for each issue raised in their briefs.¹² Further, we request that

interested parties limit their executive summary of each issue to no more than 450 words, not including citations. We intend to use the executive summaries as the basis of the comment summaries included in the issues and decision memorandum that will accompany the final determination in this investigation. We request that interested parties include footnotes for relevant citations in the executive summary of each issue. Note that Commerce has amended certain of its requirements pertaining to the service of documents in 19 CFR 351.303(f).¹³

Pursuant to 19 CFR 351.310(c), interested parties who wish to request a hearing, limited to issues raised in the case and rebuttal briefs, must submit a written request to the Assistant Secretary for Enforcement and Compliance, U.S. Department of Commerce, within 30 days after the date of publication of this notice. Requests should contain: (1) the party's name, address, and telephone number; (2) the number of participants and whether any participant is a foreign national; and (3) a list of the issues to be discussed. If a request for a hearing is made, Commerce intends to hold the hearing at a date and time to be determined. Parties should confirm by telephone the date, time, and location of the hearing two days before the scheduled date.

Postponement of Final Determination and Extension of Provisional Measures

Section 735(a)(2) of the Act provides that a final determination may be postponed until not later than 135 days after the date of the publication of the preliminary determination if, in the event of an affirmative preliminary determination, a request for such postponement is made by exporters who account for a significant proportion of exports of the subject merchandise, or in the event of a negative preliminary determination, a request for such postponement is made by the petitioner. Section 351.210(e)(2) of Commerce's regulations requires that a request by exporters for postponement of the final determination be accompanied by a request for extension of provisional measures from a four-month period to a period not more than six months in duration.

On March 26, 2025, pursuant to 19 CFR 351.210(e), Wuppermann requested that Commerce postpone the final determination and that provisional measures be extended to a period not to

exceed six months.¹⁴ On March 31, 2025, pursuant to 19 CFR 351.210(e), Tata requested that Commerce postpone the final determination and that provisional measures be extended to a period not to exceed six months.¹⁵ In accordance with section 735(a)(2)(A) of the Act and 19 CFR 351.210(b)(2)(ii), because: (1) the preliminary determination is affirmative; (2) the requesting exporters account for a significant proportion of exports of the subject merchandise; and (3) no compelling reasons for denial exist, Commerce is postponing the final determination and extending the provisional measures from a four-month period to a period not greater than six months. Accordingly, Commerce will make its final determination no later than 135 days after the date of publication of this preliminary determination.

U.S. International Trade Commission Notification

In accordance with section 733(f) of the Act, Commerce will notify the U.S. International Trade Commission (ITC) of its preliminary determination. If the final determination is affirmative, the ITC will determine before the later of 120 days after the date of this preliminary determination or 45 days after the final determination whether these imports are materially injuring, or threaten material injury to, the U.S. industry.

Notification to Interested Parties

This determination is issued and published in accordance with sections 733(f) and 777(i)(1) of the Act and 19 CFR 351.205(c).

Dated: April 3, 2025.

Christopher Abbott,

Deputy Assistant Secretary for Policy and Negotiations, performing the non-exclusive functions and duties of the Assistant Secretary for Enforcement and Compliance.

Appendix I

Scope of the Investigation

The products covered by this investigation are certain flat-rolled steel products, either clad, plated, or coated with corrosion-resistant metals such as zinc, aluminum, or zinc-, aluminum-, nickel- or iron-based alloys, whether or not corrugated or painted, varnished, laminated, or coated with plastics or other non-metallic substances in addition to the metallic coating. The products covered include coils that have a width of 12.7 mm or greater, regardless of form of coil (*e.g.*, in

¹⁴ See Wuppermann's Letter, "Request to Postpone Final Determination," dated March 26, 2025.

¹⁵ See Tata's Letter, "Request to Postpone Final Determination," dated March 31, 2025.

¹⁰ See 19 CFR 351.309(d); see also *Administrative Protective Order, Service, and Other Procedures in Antidumping and Countervailing Duty Proceedings*, 88 FR 67069, 67077 (September 29, 2023) (*APO and Service Final Rule*).

¹¹ See 19 CFR 351.309(c)(2) and (d)(2).

¹² We use the term "issue" here to describe an argument that Commerce would normally address

in a comment of the Issues and Decision Memorandum.

¹³ See *APO and Service Final Rule*.

successively superimposed layers, spirally oscillating, etc.). The products covered also include products not in coils (e.g., in straight lengths) of a thickness less than 4.75 mm and a width that is 12.7 mm or greater and that measures at least 10 times the thickness. The products covered also include products not in coils (e.g., in straight lengths) of a thickness of 4.75 mm or more and a width exceeding 150 mm and measuring at least twice the thickness. The products described above may be rectangular, square, circular, or other shape and include products of either rectangular or non-rectangular cross-section where such cross-section is achieved subsequent to the rolling process, i.e., products which have been “worked after rolling” (e.g., products which have been beveled or rounded at the edges).

For purposes of the width and thickness requirements referenced above:

(1) Where the nominal and actual measurements vary, a product is within the scope if application of either the nominal or actual measurement would place it within the scope based on the definitions set forth above, and

(2) where the width and thickness vary for a specific product (e.g., the thickness of certain products with non-rectangular cross-section, the width of certain products with non-rectangular shape, etc.), the measurement at its greatest width or thickness applies.

Steel products included in the scope of this investigation are products in which: (1) iron predominates, by weight, over each of the other contained elements; and (2) the carbon content is 2 percent or less, by weight.

Subject merchandise also includes corrosion-resistant steel that has been further processed in a third country, including but not limited to annealing, tempering, painting, varnishing, trimming, cutting, punching and/or slitting or any other processing that would not otherwise remove the merchandise from the scope of the investigations if performed in the country of manufacture of the in-scope corrosion resistant steel.

All products that meet the written physical description are within the scope of this investigation unless specifically excluded. The following products are outside of and/or specifically excluded from the scope of this investigation:

- Flat-rolled steel products either plated or coated with tin, lead, chromium, chromium oxides, both tin and lead (“terne plate”) or both chromium and chromium oxides (“tin free steel”), whether or not painted, varnished or coated with plastics or other non-metallic substances in addition to the metallic coating;

- Clad products in straight lengths of 4.7625 mm or more in composite thickness and of a width which exceeds 150 mm and measures at least twice the thickness;

- Certain clad stainless flat-rolled products, which are three-layered corrosion-resistant carbon steel flat-rolled products less than 4.75 mm in composite thickness that consist of a carbon steel flat-rolled product clad on both sides with stainless steel in a 20%–60%–20% ratio; and

Also excluded from the scope of the antidumping duty investigation on corrosion

resistant steel from Taiwan are any products covered by the existing antidumping duty order on corrosion-resistant steel from Taiwan. See *Certain Corrosion-Resistant Steel Products from India, Italy, the People's Republic of China, the Republic of Korea and Taiwan: Amended Final Affirmative Antidumping Determination for India and Taiwan, and Antidumping Duty Orders*, 81 FR 48390 (July 25, 2016); *Corrosion-Resistant Steel Products from Taiwan: Notice of Third Amended Final Determination of Sales at Less Than Fair Value Pursuant to Court Decision and Partial Exclusion from Antidumping Duty Order*, 88 FR 58245 (August 25, 2023).

Also excluded from the scope of the antidumping duty investigation on corrosion-resistant steel from the United Arab Emirates and the antidumping duty and countervailing duty investigations on corrosion-resistant steel from the Socialist Republic of Vietnam are any products covered by the existing antidumping and countervailing duty orders on corrosion-resistant steel from the People's Republic of China and the Republic of Korea and the antidumping duty order on corrosion-resistant steel from Taiwan. See *Certain Corrosion-Resistant Steel Products from India, Italy, the People's Republic of China, the Republic of Korea and Taiwan: Amended Final Affirmative Antidumping Determination for India and Taiwan, and Antidumping Duty Orders*, 81 FR 48390 (July 25, 2016); see also *Certain Corrosion-Resistant Steel Products from India, Italy, Republic of Korea and the People's Republic of China: Countervailing Duty Order*, 81 FR 48387 (July 25, 2016). This exclusion does not apply to imports of corrosion-resistant steel that are entered, or withdrawn from warehouse, for consumption in the United States for which the relevant importer and exporter certifications have been completed and maintained and all other applicable certification requirements have been met such that the entry is entered into the United States as not subject to the antidumping and countervailing duty orders on corrosion-resistant steel from the People's Republic of China, the antidumping and countervailing duty orders on corrosion-resistant steel from the Republic of Korea, or the antidumping duty order on corrosion-resistant steel from Taiwan.

The products subject to the investigation are currently classified in the Harmonized Tariff Schedule of the United States (HTSUS) under item numbers: 7210.30.0030, 7210.30.0060, 7210.41.0000, 7210.49.0030, 7210.49.0040, 7210.49.0045, 7210.49.0091, 7210.49.0095, 7210.61.0000, 7210.69.0000, 7210.70.6030, 7210.70.6060, 7210.70.6090, 7210.90.6000, 7210.90.9000, 7212.20.0000, 7212.30.1030, 7212.30.1090, 7212.30.3000, 7212.30.5000, 7212.40.1000, 7212.40.5000, 7212.50.0000, 7212.60.0000, 7225.91.0000, 7225.92.0000, 7226.99.0110, and 7226.99.0130.

The products subject to the investigation may also enter under the following HTSUS item numbers: 7210.90.1000, 7215.90.1000, 7215.90.3000, 7215.90.5000, 7217.20.1500, 7217.30.1530, 7217.30.1560, 7217.90.1000, 7217.90.5030, 7217.90.5060, 7217.90.5090, 7225.99.0090, 7226.99.0180, 7228.60.6000, 7228.60.8000, and 7229.90.1000.

The HTSUS subheadings above are provided for convenience and customs purposes only. The written description of the scope of the investigation is dispositive.

Appendix II

List of Topics Discussed in the Preliminary Decision Memorandum

- I. Summary
- II. Background
- III. Period of Investigation
- IV. Scope Comments
- V. Affiliation and Single Entity Treatment
- VI. Application of Facts Available and Use of Adverse Inferences
- VII. Discussion of the Methodology
- VIII. Currency Conversion
- IX. Recommendation

[FR Doc. 2025–06137 Filed 4–9–25; 8:45 am]

BILLING CODE 3510-DS-P

DEPARTMENT OF COMMERCE

International Trade Administration

[A–520–811]

Certain Corrosion-Resistant Steel Products From the United Arab Emirates: Preliminary Affirmative Determination of Sales at Less Than Fair Value, Postponement of Final Determination, and Extension of Provisional Measures

AGENCY: Enforcement and Compliance, International Trade Administration, Department of Commerce.

SUMMARY: The U.S. Department of Commerce (Commerce) preliminarily determines that certain corrosion-resistant steel products (CORE) from the United Arab Emirates (UAE) are being, or are likely to be, sold in the United States at less than fair value (LTFV). The period of investigation is July 1, 2023, through June 30, 2024. Interested parties are invited to comment on this preliminary determination.

DATES: Applicable April 10, 2025.

FOR FURTHER INFORMATION CONTACT: Jose Rivera or Lingjun Wang, AD/CVD Operations, Office VII, Enforcement and Compliance, International Trade Administration, U.S. Department of Commerce, 1401 Constitution Avenue NW, Washington, DC 20230; telephone: (202) 482–0842 or (202) 482–2316, respectively.

SUPPLEMENTARY INFORMATION:

Background

This preliminary determination is made in accordance with section 733(b) of the Tariff Act of 1930, as amended (the Act). Commerce published the notice of initiation of this investigation

on October 2, 2024.¹ On January 28, 2025, Commerce postponed the preliminary determination of this investigation until April 3, 2025.² On March 24, 2025, Commerce preliminarily determined that critical circumstances exist, in part.³ For a complete description of the events that followed the initiation of this investigation, see the Preliminary Decision Memorandum.⁴ A list of topics included in the Preliminary Decision Memorandum is included as Appendix II to this notice. The Preliminary Decision Memorandum is a public document and is on file electronically via Enforcement and Compliance's Antidumping and Countervailing Duty Centralized Electronic Service System (ACCESS). ACCESS is available to registered users at <https://access.trade.gov>. In addition, a complete version of the Preliminary Decision Memorandum can be accessed directly at <https://access.trade.gov/public/FRNoticesListLayout.aspx>.

Scope of the Investigation

The product covered by this investigation is CORE from UAE. For a complete description of the scope of this investigation, see Appendix I.

Scope Comments

In accordance with the *Preamble* to Commerce's regulations,⁵ in the *Initiation Notice*, Commerce set aside a period of time for parties to raise issues regarding product coverage (*i.e.*, scope).⁶ Certain interested parties commented on the scope of the investigation as it appeared in the *Initiation Notice*. For a summary of the product coverage comments and rebuttal responses

¹ See *Certain Corrosion-Resistant Steel Products from Australia, Brazil, Canada, Mexico, the Netherlands, South Africa, Taiwan, the Republic of Türkiye, the United Arab Emirates, and the Socialist Republic of Vietnam: Initiation of Less-Than-Fair-Value Investigations*, 89 FR 80196 (October 2, 2024) (*Initiation Notice*).

² See *Certain Corrosion-Resistant Steel Products from Australia, Brazil, Canada, Mexico, the Netherlands, South Africa, Taiwan, the Republic of Türkiye, the United Arab Emirates, and the Socialist Republic of Vietnam: Postponement of Preliminary Determinations in the Less-Than-Fair-Value Investigations*, 90 FR 8260 (January 28, 2025).

³ See *Certain Corrosion-Resistant Steel Products from the United Arab Emirates and South Africa: Preliminary Affirmative Determination, In Part, of Critical Circumstances*, 90 FR 14599 (April 3, 2025).

⁴ See Memorandum, "Decision Memorandum for the Preliminary Determination in the Less-Than-Fair-Value Investigation of Certain Corrosion-Resistant Steel Products from the United Arab Emirates" dated concurrently with, and hereby adopted by, this notice (Preliminary Decision Memorandum).

⁵ See *Antidumping Duties; Countervailing Duties, Final Rule*, 62 FR 27296, 27323 (May 19, 1997) (*Preamble*).

⁶ See *Initiation Notice*, 89 FR at 80197.

submitted to the record for this investigation and accompanying discussion and analysis of all comments timely received, see the Preliminary Scope Decision Memorandum.⁷ Commerce is not preliminarily modifying the scope language as it appeared in the *Initiation Notice*. In the Preliminary Scope Decision Memorandum, Commerce established the deadline for parties to submit scope case and rebuttal briefs.⁸

Methodology

Commerce is conducting this investigation in accordance with section 731 of the Act. Commerce calculated export prices in accordance with section 772(a) of the Act. Normal value is calculated in accordance with section 773 of the Act. In addition, Commerce has relied on partial adverse facts available under sections 776(a) and (b) of the Act for Al Ghurair Iron & Steel LLC (AGIS) and United Iron & Steel Company LLC (UISC). For a full description of the methodology underlying the preliminary determination, see the Preliminary Decision Memorandum.

All-Others Rate

Sections 733(d)(1)(ii) and 735(c)(5)(A) of the Act provide that in the preliminary determination Commerce shall determine an estimated all-others rate for all exporters and producers not individually examined. This rate shall be an amount equal to the weighted average of the estimated weighted-average dumping margins established for exporters and producers individually investigated, excluding any zero and *de minimis* margins, and any margins determined entirely under section 776 of the Act.

Commerce preliminarily calculated estimated weighted-average dumping margins for AGIS and UISC that are not zero, *de minimis*, or based entirely on facts otherwise available. Commerce calculated the all-others rate using a weighted average of the estimated weighted-average dumping margins calculated for the examined respondents using each company's publicly-ranged values for the merchandise under consideration.⁹

⁷ See Memorandum, "Preliminary Scope Decision Memorandum," dated concurrently with this notice (Preliminary Scope Decision Memorandum).

⁸ *Id.*

⁹ With two respondents under examination, Commerce normally calculates: (A) a weighted-average of the estimated weighted-average dumping margins calculated for the examined respondents; (B) a simple average of the estimated weighted-average dumping margins calculated for the examined respondents; and (C) a weighted-average of the estimated weighted-average dumping margins

Preliminary Determination

Commerce preliminarily determines that the following estimated weighted-average dumping margins exist:

Exporter/producer	Weighted-average dumping margin (percent)
Al Ghurair Iron & Steel LLC	7.01
United Iron & Steel Company LLC/United Metal Coating ¹⁰ ...	16.37
All Others	8.24

Suspension of Liquidation

In accordance with section 733(d)(2) of the Act, Commerce will direct U.S. Customs and Border Protection (CBP) to suspend liquidation of entries of subject merchandise, as described in Appendix I, entered, or withdrawn from warehouse, for consumption on or after the date of publication of this notice in the **Federal Register**. Further, pursuant to section 733(d)(1)(B) of the Act and 19 CFR 351.205(d), Commerce will instruct CBP to require a cash deposit equal to the estimated weighted-average dumping margin or the estimated all-others rate, as follows: (1) the cash deposit rate for the respondents listed above will be equal to the company-specific estimated weighted-average dumping margins determined in this preliminary determination; (2) if the exporter is not a respondent identified above, but the producer is, then the cash deposit rate will be equal to the company-specific estimated weighted-average dumping margin established for that producer of the subject merchandise; and (3) the cash deposit rate for all other producers and exporters will be equal to the all-others estimated weighted-average dumping margin.

Section 733(e)(2) of the Act provides that, given an affirmative determination

calculated for the examined respondents using each company's publicly-ranged U.S. sales values for the merchandise under consideration. Commerce then compares (B) and (C) to (A) and selects the rate closest to (A) as the most appropriate rate for all other producers and exporters. See, e.g., *Ball Bearings and Parts Thereof from France, Germany, Italy, Japan, and the United Kingdom: Final Results of Antidumping Duty Administrative Reviews, Final Results of Changed-Circumstances Review, and Revocation of an Order in Part*, 75 FR 53661, 53662 (September 1, 2010), and accompanying Issues and Decision Memorandum at Comment 1. As complete publicly ranged sales data were available, Commerce based the all-others rate on the publicly ranged sales data of the mandatory respondents. For a complete analysis of the data, see the All-Others Rate Calculation Memorandum.

¹⁰ Commerce preliminarily determines that United Iron & Steel Company LLC and United Metal Coating comprise a single entity. See Preliminary Decision Memorandum.

of critical circumstances, any suspension of liquidation shall apply to unliquidated entries of subject merchandise entered, or withdrawn from warehouse, for consumption on or after the later of: (a) the date which is 90 days before the date on which the suspension of liquidation was first ordered; or (b) the date on which notice of initiation of the investigation was published. Commerce preliminarily found that critical circumstances exist for imports of subject merchandise produced or exported by all other producers or exporters. In accordance with section 733(e)(2)(A) of the Act, the suspension of liquidation shall apply to unliquidated entries of shipments of subject merchandise from the producers or exporters identified in this paragraph that were entered, or withdrawn from warehouse, for consumption on or after the date which is 90 days before the publication of this notice. These suspension of liquidation instructions will remain in effect until further notice.

Disclosure

Commerce intends to disclose its calculations and analysis performed to interested parties in this preliminary determination within five days of any public announcement or, if there is no public announcement, within five days of the date of publication of this notice in accordance with 19 CFR 351.224(b).

Consistent with 19 CFR 351.224(e), Commerce will analyze and, if appropriate, correct any timely allegations of significant ministerial errors by amending the preliminary determination. However, consistent with 19 CFR 351.224(d), Commerce will not consider incomplete allegations that do not address the significance standard under 19 CFR 351.224(g) following the preliminary determination. Instead, Commerce will address such allegations in the final determination together with issues raised in the case briefs or other written comments.

Verification

As provided in section 782(i)(1) of the Act, Commerce intends to verify the information relied upon in making its final determination.

Public Comment

Case briefs or other written comments, excluding scope comments, may be submitted to the Assistant Secretary for Enforcement and Compliance no later than seven days after the date on which the last verification report is issued in this investigation. Rebuttal briefs, limited to issues raised in the case briefs, may be filed not later than five days after the

date for filing case briefs.¹¹ Interested parties who submit case briefs or rebuttal briefs in this proceeding must submit: (1) a table of contents listing each issue; and (2) a table of authorities.¹²

As provided under 19 CFR 351.309(c)(2) and (d)(2), in prior proceedings we have encouraged interested parties to provide an executive summary of their brief that should be limited to five pages total, including footnotes. In this investigation, we instead request that interested parties provide at the beginning of their briefs a public, executive summary for each issue raised in their briefs.¹³ Further, we request that interested parties limit their executive summary of each issue to no more than 450 words, not including citations. We intend to use the executive summaries as the basis of the comment summaries included in the issues and decision memorandum that will accompany the final determination in this investigation. We request that interested parties include footnotes for relevant citations in the executive summary of each issue. Note that Commerce has amended certain of its requirements pertaining to the service of documents in 19 CFR 351.303(f).¹⁴

Pursuant to 19 CFR 351.310(c), interested parties who wish to request a hearing, limited to issues raised in the case and rebuttal briefs, must submit a written request to the Assistant Secretary for Enforcement and Compliance, U.S. Department of Commerce, within 30 days after the date of publication of this notice. Requests should contain: (1) the party's name, address, and telephone number; (2) the number of participants and whether any participant is a foreign national; and (3) a list of the issues to be discussed. If a request for a hearing is made, Commerce intends to hold the hearing at a date and time to be determined. Parties should confirm by telephone the date, time, and location of the hearing two days before the scheduled date.

Postponement of Final Determination and Extension of Provisional Measures

Section 735(a)(2) of the Act provides that a final determination may be postponed until not later than 135 days

after the date of the publication of the preliminary determination if, in the event of an affirmative preliminary determination, a request for such postponement is made by exporters who account for a significant proportion of exports of the subject merchandise, or in the event of a negative preliminary determination, a request for such postponement is made by the petitioner. Section 351.210(e)(2) of Commerce's regulations requires that a request by exporters for postponement of the final determination be accompanied by a request for extension of provisional measures from a four-month period to a period not more than six months in duration.

On March 31, 2025, the petitioners requested postponement of final determination.¹⁵ On April 1, 2025, pursuant to 19 CFR 351.210(e), UISC and AGIS requested that Commerce postpone the final determination and that provisional measures be extended to a period not to exceed six months.¹⁶ In accordance with section 735(a)(2)(A) of the Act and 19 CFR 351.210(b)(2)(ii), because: (1) the preliminary determination is affirmative; (2) the requesting exporters account for a significant proportion of exports of the subject merchandise; and (3) no compelling reasons for denial exist, Commerce is postponing the final determination and extending the provisional measures from a four-month period to a period not greater than six months. Accordingly, Commerce will make its final determination no later than 135 days after the date of publication of this preliminary determination.

U.S. International Trade Commission (ITC) Notification

In accordance with section 733(f) of the Act, Commerce will notify the ITC of its preliminary determination. If the final determination is affirmative, the ITC will determine before the later of 120 days after the date of this preliminary determination or 45 days after the final determination whether these imports are materially injuring, or threaten material injury to, the U.S. industry.

Notification to Interested Parties

This determination is issued and published in accordance with sections

¹¹ See 19 CFR 351.309(d); see also *Administrative Protective Order, Service, and Other Procedures in Antidumping and Countervailing Duty Proceedings*, 88 FR 67069, 67077 (September 29, 2023) (*APO and Service Final Rule*).

¹² See 19 CFR 351.309(c)(2) and (d)(2).

¹³ We use the term "issue" here to describe an argument that Commerce would normally address in a comment of the Issues and Decision Memorandum.

¹⁴ See *APO and Service Final Rule*.

¹⁵ See Petitioners' Letter, "Request for Postponement of Final Determinations," dated March 31, 2025.

¹⁶ See UISC's and AGIS' Letters, "Request for Postponement of Final Determinations," dated April 1, 2025, and "Request to Extend the Deadline for the Final Determination," dated April 1, 2025.

733(f) and 777(i)(1) of the Act, and 19 CFR 351.205(c).

Dated: April 3, 2025.

Christopher Abbott,

Deputy Assistant Secretary for Policy and Negotiations, performing the Non-exclusive Functions and Duties of the Assistant Secretary for Enforcement and Compliance.

Appendix I

Scope of the Investigation

The products covered by this investigation are certain flat-rolled steel products, either clad, plated, or coated with corrosion-resistant metals such as zinc, aluminum, or zinc-, aluminum-, nickel- or iron-based alloys, whether or not corrugated or painted, varnished, laminated, or coated with plastics or other non-metallic substances in addition to the metallic coating. The products covered include coils that have a width of 12.7 mm or greater, regardless of form of coil (*e.g.*, in successively superimposed layers, spirally oscillating, *etc.*). The products covered also include products not in coils (*e.g.*, in straight lengths) of a thickness less than 4.75 mm and a width that is 12.7 mm or greater and that measures at least 10 times the thickness. The products covered also include products not in coils (*e.g.*, in straight lengths) of a thickness of 4.75 mm or more and a width exceeding 150 mm and measuring at least twice the thickness. The products described above may be rectangular, square, circular, or other shape and include products of either rectangular or non-rectangular cross-section where such cross-section is achieved subsequent to the rolling process, *i.e.*, products which have been “worked after rolling” (*e.g.*, products which have been beveled or rounded at the edges).

For purposes of the width and thickness requirements referenced above:

(1) Where the nominal and actual measurements vary, a product is within the scope if application of either the nominal or actual measurement would place it within the scope based on the definitions set forth above, and

(2) where the width and thickness vary for a specific product (*e.g.*, the thickness of certain products with non-rectangular cross-section, the width of certain products with non-rectangular shape, *etc.*), the measurement at its greatest width or thickness applies.

Steel products included in the scope of this investigation are products in which: (1) iron predominates, by weight, over each of the other contained elements; and (2) the carbon content is 2 percent or less, by weight.

Subject merchandise also includes corrosion-resistant steel that has been further processed in a third country, including but not limited to annealing, tempering, painting, varnishing, trimming, cutting, punching and/or slitting or any other processing that would not otherwise remove the merchandise from the scope of the investigations if performed in the country of manufacture of the in-scope corrosion resistant steel.

All products that meet the written physical description are within the scope of this investigation unless specifically excluded. The following products are outside of and/or

specifically excluded from the scope of this investigation:

- Flat-rolled steel products either plated or coated with tin, lead, chromium, chromium oxides, both tin and lead (“terne plate”) or both chromium and chromium oxides (“tin free steel”), whether or not painted, varnished or coated with plastics or other non-metallic substances in addition to the metallic coating;

- Clad products in straight lengths of 4.7625 mm or more in composite thickness and of a width which exceeds 150 mm and measures at least twice the thickness;

- Certain clad stainless flat-rolled products, which are three-layered corrosion-resistant carbon steel flat-rolled products less than 4.75 mm in composite thickness that consist of a carbon steel flat-rolled product clad on both sides with stainless steel in a 20%–60%–20% ratio; and

Also excluded from the scope of the antidumping duty investigation on corrosion resistant steel from Taiwan are any products covered by the existing antidumping duty order on corrosion-resistant steel from Taiwan. *See Certain Corrosion-Resistant Steel Products from India, Italy, the People’s Republic of China, the Republic of Korea and Taiwan: Amended Final Affirmative Antidumping Determination for India and Taiwan, and Antidumping Duty Orders*, 81 FR 48390 (July 25, 2016); *Corrosion-Resistant Steel Products from Taiwan: Notice of Third Amended Final Determination of Sales at Less Than Fair Value Pursuant to Court Decision and Partial Exclusion from Antidumping Duty Order*, 88 FR 58245 (August 25, 2023).

Also excluded from the scope of the antidumping duty investigation on corrosion-resistant steel from the United Arab Emirates and the antidumping duty and countervailing duty investigations on corrosion-resistant steel from the Socialist Republic of Vietnam are any products covered by the existing antidumping and countervailing duty orders on corrosion-resistant steel from the People’s Republic of China and the Republic of Korea and the antidumping duty order on corrosion-resistant steel from Taiwan. *See Certain Corrosion-Resistant Steel Products from India, Italy, the People’s Republic of China, the Republic of Korea and Taiwan: Amended Final Affirmative Antidumping Determination for India and Taiwan, and Antidumping Duty Orders*, 81 FR 48390 (July 25, 2016); *see also Certain Corrosion-Resistant Steel Products from India, Italy, Republic of Korea and the People’s Republic of China: Countervailing Duty Order*, 81 FR 48387 (July 25, 2016). This exclusion does not apply to imports of corrosion-resistant steel that are entered, or withdrawn from warehouse, for consumption in the United States for which the relevant importer and exporter certifications have been completed and maintained and all other applicable certification requirements have been met such that the entry is entered into the United States as not subject to the antidumping and countervailing duty orders on corrosion-resistant steel from the People’s Republic of China, the antidumping and countervailing duty orders on corrosion-resistant steel from the Republic of Korea, or the antidumping

duty order on corrosion-resistant steel from Taiwan.

The products subject to the investigation are currently classified in the Harmonized Tariff Schedule of the United States (HTSUS) under item numbers: 7210.30.0030, 7210.30.0060, 7210.41.0000, 7210.49.0030, 7210.49.0040, 7210.49.0045, 7210.49.0091, 7210.49.0095, 7210.61.0000, 7210.69.0000, 7210.70.6030, 7210.70.6060, 7210.70.6090, 7210.90.6000, 7210.90.9000, 7212.20.0000, 7212.30.1030, 7212.30.1090, 7212.30.3000, 7212.30.5000, 7212.40.1000, 7212.40.5000, 7212.50.0000, 7212.60.0000, 7225.91.0000, 7225.92.0000, 7226.99.0110, and 7226.99.0130.

The products subject to the investigation may also enter under the following HTSUS item numbers: 7210.90.1000, 7215.90.1000, 7215.90.3000, 7215.90.5000, 7217.20.1500, 7217.30.1530, 7217.30.1560, 7217.90.1000, 7217.90.5030, 7217.90.5060, 7217.90.5090, 7225.99.0090, 7226.99.0180, 7228.60.6000, 7228.60.8000, and 7229.90.1000.

The HTSUS subheadings above are provided for convenience and customs purposes only. The written description of the scope of the investigation is dispositive.

Appendix II

List of Topics Discussed in the Preliminary Decision Memorandum

- I. Summary
- II. Background
- III. Period of Investigation
- IV. Scope Comments
- V. Preliminary Determination of Critical Circumstances
- VI. Affiliation And Single Entity Treatment
- VII. Application Of Facts Available And Use Of Adverse Inference
- VIII. Discussion of the Methodology
- IX. Calculation of Normal Value Based on Comparison Market Prices
- X. Currency Conversion
- XI. Recommendation

[FR Doc. 2025–06141 Filed 4–9–25; 8:45 am]

BILLING CODE 3510-DS-P

DEPARTMENT OF COMMERCE

International Trade Administration

[C–570–146]

Certain Freight Rail Couplers and Parts Thereof From the People’s Republic of China: Rescission of Countervailing Duty Administrative Review; 2023

AGENCY: Enforcement and Compliance, International Trade Administration, Department of Commerce.

SUMMARY: The U.S. Department of Commerce (Commerce) is rescinding the administrative review of the countervailing duty (CVD) order on certain freight rail couplers and parts thereof (freight rail couplers) from the People’s Republic of China (China). The period of review (POR) is March 3, 2023, through December 31, 2023.

DATES: Applicable April 10, 2025.

FOR FURTHER INFORMATION CONTACT:

Whitley Herndon, AD/CVD Operations, Office IX, Enforcement and Compliance, International Trade Administration, U.S. Department of Commerce, 1401 Constitution Avenue NW, Washington, DC 20230; telephone: 202-482-6274.

SUPPLEMENTARY INFORMATION:**Background**

On July 1, 2024, Commerce published in the **Federal Register** a notice of opportunity to request an administrative review of the CVD order on freight rail couplers from China.¹ Commerce received a timely request for review of the CVD order from the Coalition of Freight Coupler Producers (the petitioner) for certain producers/exporters of subject merchandise.²

On August 10, 2024, Commerce published the initiation notice in the **Federal Register** for thirteen companies, in accordance with section 751(a) of the Tariff Act of 1930, as amended (the Act).³ On September 23, 2024, we notified interested parties that information from U.S. Customs and Border Protection (CBP) indicated that there were no POR entries of the subject merchandise.⁴ On September 30, 2024, the petitioner submitted comments on the lack of entries in the CBP data, stating that there may be entries of subject merchandise that entered as a product other than an entry for consumption (such as entries of subject merchandise that entered mounted to railcars), or under harmonized tariff schedule subheadings listed in the scope of the CVD order.⁵ On January 8, 2025, we referred the petitioner's concerns to CBP for further investigation.⁶ We did not receive any additional comments in this administrative review.

Rescission of Review

Pursuant to 19 CFR 351.213(d)(3), it is Commerce's practice to rescind an administrative review of a CVD order where it concludes that there were there are no entries of subject merchandise during the POR for which liquidation is

suspended.⁷ Normally, upon completion of an administrative review, the suspended entries are liquidated at the CVD rates calculated for the review period.⁸ Therefore, for an administrative review to be conducted, there must be a reviewable, suspended entry that Commerce can instruct CBP to liquidate at the calculated CVD rates for the review period.⁹ As noted above, there were no suspended entries of subject merchandise for any companies subject to this review during the POR. Accordingly, in the absence of reviewable, suspended entries of subject merchandise during the POR, we are hereby rescinding this administrative review in its entirety, in accordance with 19 CFR 351.213(d)(3).

Assessment

Commerce will instruct CBP to assess countervailing duties on all appropriate entries. Countervailing duties shall be assessed at rates equal to the cash deposit rate of estimated countervailing duties required at the time of entry, or withdrawal from warehouse, for consumption, in accordance with 19 CFR 351.212(c)(1)(i). Commerce intends to issue assessment instructions to CBP no earlier than 35 days after the date of publication of this rescission notice in the **Federal Register**.

Notification Regarding Administrative Protective Order

This notice serves as a final reminder to parties subject to administrative protective order (APO) of their responsibility concerning the return or destruction of proprietary information disclosed under APO in accordance with 19 CFR 351.305, which continues to govern business proprietary information in this segment of the proceeding. Timely written notification of the return or destruction of the APO materials or conversion to judicial protective order is hereby requested. Failure to comply with regulations and terms of an APO is a violation, which is subject to sanction.

Notification to Interested Parties

This notice is issued and published in accordance with sections 751(a)(1) and

777(i)(l) of the Act, and 19 CFR 351.213(d)(4).

Dated: April 7, 2025.

Scot Fullerton,

Acting Deputy Assistant Secretary for Antidumping and Countervailing Duty Operations.

[FR Doc. 2025-06144 Filed 4-9-25; 8:45 am]

BILLING CODE 3510-DS-P

DEPARTMENT OF COMMERCE**International Trade Administration**

[A-583-878]

Certain Corrosion-Resistant Steel Products From Taiwan: Preliminary Affirmative Determination of Sales at Less Than Fair Value, Postponement of Final Determination, and Extension of Provisional Measures

AGENCY: Enforcement and Compliance, International Trade Administration, Department of Commerce.

SUMMARY: The U.S. Department of Commerce (Commerce) preliminarily determines that certain corrosion-resistant steel products (CORE) from Taiwan are being, or are likely to be, sold in the United States at less than fair value (LTFV). The period of investigation is July 1, 2023, through June 30, 2024. Interested parties are invited to comment on this preliminary determination.

DATES: Applicable April 10, 2025.

FOR FURTHER INFORMATION CONTACT: Monique Cummings or Preston Cox, AD/CVD Operations, Office VI, Enforcement and Compliance, International Trade Administration, U.S. Department of Commerce, 1401 Constitution Avenue NW, Washington, DC 20230; telephone: (202) 482-3996 or (240) 956-8630, respectively.

SUPPLEMENTARY INFORMATION:**Background**

This preliminary determination is made in accordance with section 733(b) of the Tariff Act of 1930, as amended (the Act). Commerce published the notice of initiation of this investigation on October 2, 2024.¹ On January 28, 2025, Commerce postponed the preliminary determination of this investigation until April 3, 2025.²

¹ See *Certain Corrosion-Resistant Steel Products from Australia, Brazil, Canada, Mexico, the Netherlands, South Africa, Taiwan, the Republic of Türkiye, the United Arab Emirates, and the Socialist Republic of Vietnam: Initiation of Less-Than-Fair-Value Investigations*, 89 FR 80196 (October 2, 2024) (*Initiation Notice*).

² See *Certain Corrosion-Resistant Steel Products from Australia, Brazil, Canada, Mexico,*

¹ See *Antidumping or Countervailing Duty Order, Finding, or Suspended Investigation: Opportunity To Request Administrative Review and Join Annual Inquiry Service List*, 89 FR 54437 (July 1, 2024).

² See Petitioner's Letter, "Request for Administrative Review," dated July 24, 2024.

³ See *Initiation of Antidumping and Countervailing Duty Administrative Reviews*, 89 FR 66035 (August 10, 2024).

⁴ See Memorandum, "Release of Customs Entry Data from U.S. Customs and Border Protection (CBP)," dated September 23, 2024.

⁵ See Petitioner's Letter, "Comments on CBP Release of Data," dated September 30, 2024.

⁶ See Commerce's Letter, "Evasion Allegation Cover Letter," dated January 7, 2025.

⁷ See, e.g., *Welded Line Pipe from the Republic of Turkey: Rescission of the Antidumping Duty Administrative Review; 2019-2020*, 87 FR 27988 (May 10, 2022); see also, e.g., *Certain Softwood Lumber Products from Canada: Final Results and Final Rescission, in Part, of the Countervailing Duty Administrative Review, 2020*, 87 FR 48455 (August 9, 2022); and *Certain Non-Refillable Steel Cylinders from the People's Republic of China: Rescission of Countervailing Duty Administrative Review; 2020-2021*, 87 FR 64008 (October 21, 2022).

⁸ See 19 CFR 351.212(b)(2).

⁹ See 19 CFR 351.212(d)(3).

For a complete description of the events that followed the initiation of this investigation, see the Preliminary Decision Memorandum.³ A list of topics addressed in the Preliminary Decision Memorandum is included in Appendix II to this notice. The Preliminary Decision Memorandum is a public document and is on file electronically via Enforcement and Compliance's Antidumping and Countervailing Duty Centralized Electronic Service System (ACCESS). ACCESS is available to registered users at <https://access.trade.gov>. In addition, a complete version of the Preliminary Decision Memorandum can be accessed directly at <https://access.trade.gov/public/FRNoticesListLayout.aspx>.

Scope of the Investigation

The product covered by this investigation is CORE from Taiwan. For a complete description of the scope of this investigation, see Appendix I.

Scope Comments

In accordance with the *Preamble* to Commerce's regulations,⁴ in the *Initiation Notice*, Commerce set aside a period of time for parties to raise issues regarding product coverage (*i.e.*, scope).⁵ Certain interested parties commented on the scope of the investigation as it appeared in the *Initiation Notice*. For a summary of the product coverage comments and rebuttal responses submitted to the record for this investigation and accompanying discussion and analysis of all comments timely received, see the Preliminary Scope Decision Memorandum.⁶ Commerce is not preliminarily modifying the scope language as it appeared in the *Initiation Notice*. In the Preliminary Scope Decision Memorandum, Commerce established the deadline for parties to submit scope case and rebuttal briefs.⁷

Methodology

Commerce is conducting this investigation in accordance with section

Netherlands, South Africa, Taiwan, Turkey, United Arab Emirates, and Vietnam: Postponement of Preliminary Determinations of Antidumping Duty Investigations, 90 FR 8260 (January 28, 2025).

³ See Memorandum, "Decision Memorandum for the Preliminary Affirmative Determination in the Less-Than-Fair-Value Investigation of Certain Corrosion-Resistant Steel Products from Taiwan," dated concurrently with, and hereby adopted by, this notice (Preliminary Decision Memorandum).

⁴ See *Antidumping Duties; Countervailing Duties, Final Rule*, 62 FR 27296, 27323 (May 19, 1997) (*Preamble*).

⁵ See *Initiation Notice*, 89 FR at 80197.

⁶ See Memorandum, "Preliminary Scope Decision Memorandum," dated concurrently with this notice (Preliminary Scope Decision Memorandum).

⁷ *Id.*

731 of the Act. Commerce calculated export prices and constructed export prices in accordance with sections 772(a) and (b) of the Act, respectively. Normal value is calculated in accordance with section 773 of the Act. Furthermore, pursuant to sections 776(a) and (b) of the Act, Commerce has preliminarily relied upon facts otherwise available, with adverse inferences, to assign an estimated weighted-average dumping margin to Sheng Yu Steel Co. Ltd., Kounan Steel Co. Ltd. and Meglobe Co. Ltd.⁸ For a full description of the methodology underlying the preliminary determination, see the Preliminary Decision Memorandum.

All-Others Rate

Sections 733(d)(1)(A)(ii) and 735(c)(5)(A) of the Act provide that, in the preliminary determination, Commerce shall determine an estimated all-others rate for all exporters and producers not individually examined. This rate shall be an amount equal to the weighted average of the estimated weighted-average dumping margins established for exporters and producers individually investigated, excluding any zero and *de minimis* margins, and any margins determined entirely under section 776 of the Act.

In this investigation, Commerce calculated an individual estimated weighted-average dumping margin for Yieh Phui Enterprise Co., Ltd. (Yieh Phui), the only individually-examined exporter/producer in this investigation. Because the only individually calculated dumping margin is not zero, *de minimis*, or based entirely on facts otherwise available, the estimated weighted-average dumping margin calculated for Yieh Phui is the margin assigned to all other producers and exporters, pursuant to section 735(c)(5)(A) of the Act.

Rate for Non-Responsive Companies

Three potential exporters and/or producers of CORE from Taiwan did not respond to Commerce's quantity and value (Q&V) questionnaire (*i.e.*, the non-responsive companies).⁹ We find that, by not responding to the Q&V questionnaire, these companies withheld requested information and significantly impeded this proceeding. Thus, in reaching our preliminary determination, pursuant to sections 776(a)(1) and 776(a)(2)(A), (B), and (C)

⁸ See Preliminary Decision Memorandum.

⁹ The companies that failed to respond to Commerce's Q&V questionnaire are: (1) Sheng Yu Steel Co. Ltd., (2) Kounan Steel Co. Ltd., and (3) Meglobe Co. Ltd. We refer to these companies, collectively, as the "non-responsive companies."

of the Act, we are basing the antidumping duty (AD) rate for the non-responsive companies on facts otherwise available.

We further preliminarily determine that an adverse inference is warranted, pursuant to section 776(b) of the Act. By failing to submit responses to Commerce's Q&V questionnaire, the non-responsive companies did not cooperate to the best of their ability in this investigation. Accordingly, we preliminarily find that an adverse inference is warranted to ensure that the non-responsive companies will not obtain a more favorable result than had they fully complied with our request for information. For more information on the application of adverse facts available to the non-responsive companies, see "Use of Facts Otherwise Available With Adverse Inferences" in the Preliminary Decision Memorandum.

Preliminary Determination

Commerce preliminarily determines that the following estimated weighted-average dumping margins exist:

Producer/exporter	Weighted-average dumping margin (percent)
Yieh Phui Enterprise Co., Ltd	2.64
Sheng Yu Steel Co. Ltd	*67.90
Kounan Steel Co. Ltd	*67.90
Meglobe Co. Ltd	*67.90
All Others	2.64

*Rate is based on facts available with adverse inferences.

Suspension of Liquidation

In accordance with section 733(d)(2) of the Act, Commerce will direct U.S. Customs and Border Protection (CBP) to suspend liquidation of entries of subject merchandise, as described in Appendix I, entered, or withdrawn from warehouse, for consumption on or after the date of publication of this notice in the **Federal Register**. Further, pursuant to section 733(d)(1)(B) of the Act and 19 CFR 351.205(d), Commerce will instruct CBP to require a cash deposit equal to the estimated weighted-average dumping margin or the estimated all-others rate, as follows: (1) the cash deposit rate for the respondents listed above will be equal to the company-specific estimated weighted-average dumping margin determined in this preliminary determination; (2) if the exporter is not a respondent identified above, but the producer is, then the cash deposit rate will be equal to the company-specific estimated weighted-average dumping margin established for that producer of the subject

merchandise; and (3) the cash deposit rate for all other producers and exporters will be equal to the all-others estimated weighted-average dumping margin. These suspension of liquidation instructions will remain in effect until further notice.

Disclosure

Commerce intends to disclose its calculations and analysis performed to interested parties in this preliminary determination within five days of any public announcement or, if there is no public announcement, within five days of the date of publication of this notice in the **Federal Register** in accordance with 19 CFR 351.224(b).

Consistent with 19 CFR 351.224(e), Commerce will analyze and, if appropriate, correct any timely allegations of significant ministerial errors by amending the preliminary determination. However, consistent with 19 CFR 351.224(d), Commerce will not consider incomplete allegations that do not address the significance standard under 19 CFR 351.224(g) following the preliminary determination. Instead, Commerce will address such allegations in the final determination together with issues raised in the case briefs or other written comments.

Verification

As provided in section 782(i)(1) of the Act, Commerce intends to verify the information relied upon in making its final determination.

Public Comment

Case briefs or other written comments, excluding scope comments, may be submitted to the Assistant Secretary for Enforcement and Compliance no later than seven days after the date on which the last verification report is issued in this investigation. Rebuttal briefs, limited to issues raised in the case briefs, may be filed not later than five days after the date for filing case briefs.¹⁰ Interested parties who submit case briefs or rebuttal briefs in this proceeding must submit: (1) a table of contents listing each issue; and (2) a table of authorities.¹¹

As provided under 19 CFR 351.309(c)(2) and (d)(2), in prior proceedings we have encouraged interested parties to provide an executive summary of their briefs that should be limited to five pages total,

including footnotes. In this investigation, we instead request that interested parties provide at the beginning of their briefs a public, executive summary for each issue raised in their briefs.¹² Further, we request that interested parties limit their executive summary of each issue to no more than 450 words, not including citations. We intend to use the public executive summaries as the basis of the comment summaries included in the issues and decision memorandum that will accompany the final determination in this investigation. We request that interested parties include footnotes for relevant citations in the public executive summary of each issue. Note that Commerce has amended certain of its requirements pertaining to the service of documents in 19 CFR 351.303(f).¹³

Pursuant to 19 CFR 351.310(c), interested parties who wish to request a hearing, limited to issues raised in the case and rebuttal briefs, must submit a written request to the Assistant Secretary for Enforcement and Compliance, U.S. Department of Commerce, within 30 days after the date of publication of this notice. Requests should contain: (1) the party's name, address, and telephone number; (2) the number of participants and whether any participant is a foreign national; and (3) a list of the issues to be discussed. If a request for a hearing is made, Commerce intends to hold the hearing at a date and time to be determined. Parties should confirm by telephone the date, time, and location of the hearing two days before the scheduled date.

Postponement of Final Determination and Extension of Provisional Measures

Section 735(a)(2) of the Act provides that a final determination may be postponed until not later than 135 days after the date of the publication of the preliminary determination if, in the event of an affirmative preliminary determination, a request for such postponement is made by exporters who account for a significant proportion of exports of the subject merchandise, or in the event of a negative preliminary determination, a request for such postponement is made by the petitioner. Pursuant to 19 CFR 351.210(e)(2), Commerce requires that requests by respondents for postponement of a final AD determination be accompanied by a request for extension of provisional measures from a four-month period to a

period not more than six months in duration.

On April 2, 2025, pursuant to 19 CFR 351.210(e), Yieh Phui requested that Commerce postpone the final determination and that provisional measures be extended to a period not to exceed six months.¹⁴ In accordance with section 735(a)(2)(A) of the Act and 19 CFR 351.210(b)(2)(ii), because: (1) the preliminary determination is affirmative; (2) the requesting exporter account for a significant proportion of exports of the subject merchandise; and (3) no compelling reasons for denial exist, Commerce is postponing the final determination and extending the provisional measures from a four-month period to a period not greater than six months. Accordingly, Commerce's final determination will be published no later than 135 days after the date of publication of this preliminary determination.

U.S. International Trade Commission (ITC) Notification

In accordance with section 733(f) of the Act, Commerce will notify the ITC of its preliminary determination. If the final determination is affirmative, the ITC will determine before the later of 120 days after the date of this preliminary determination or 45 days after the final determination whether these imports are materially injuring, or threaten material injury to, the U.S. industry.

Notification to Interested Parties

This determination is issued and published in accordance with sections 733(f) and 777(i)(1) of the Act, and 19 CFR 351.205(c).

Dated: April 3, 2025.

Christopher Abbott,

Deputy Assistant Secretary for Policy and Negotiations, performing the non-exclusive functions and duties of the Assistant Secretary for Enforcement and Compliance.

Appendix I—Scope of the Investigation

The products covered by this investigation are certain flat-rolled steel products, either clad, plated, or coated with corrosion-resistant metals such as zinc, aluminum, or zinc-, aluminum-, nickel- or iron-based alloys, whether or not corrugated or painted, varnished, laminated, or coated with plastics or other non-metallic substances in addition to the metallic coating. The products covered include coils that have a width of 12.7 mm or greater, regardless of form of coil (*e.g.*, in successively superimposed layers, spirally oscillating, *etc.*). The products covered also include products not in coils (*e.g.*, in straight lengths) of a thickness less than 4.75 mm and

¹⁰ See 19 CFR 351.309(d); see also *Administrative Protective Order, Service, and Other Procedures in Antidumping and Countervailing Duty Proceedings*, 88 FR 67069, 67077 (September 29, 2023) (*APO and Service Final Rule*).

¹¹ See 19 CFR 351.309(c)(2) and (d)(2).

¹² We use the term "issue" here to describe an argument that Commerce would normally address in a comment of the Issues and Decision Memorandum.

¹³ See *APO and Service Final Rule*.

¹⁴ See Yieh Phui's Letter, "Request to Extend Final Determination," dated April 2, 2025.

a width that is 12.7 mm or greater and that measures at least 10 times the thickness. The products covered also include products not in coils (e.g., in straight lengths) of a thickness of 4.75 mm or more and a width exceeding 150 mm and measuring at least twice the thickness. The products described above may be rectangular, square, circular, or other shape and include products of either rectangular or non-rectangular cross-section where such cross-section is achieved subsequent to the rolling process, i.e., products which have been “worked after rolling” (e.g., products which have been beveled or rounded at the edges).

For purposes of the width and thickness requirements referenced above:

(1) Where the nominal and actual measurements vary, a product is within the scope if application of either the nominal or actual measurement would place it within the scope based on the definitions set forth above, and

(2) where the width and thickness vary for a specific product (e.g., the thickness of certain products with non-rectangular cross-section, the width of certain products with non-rectangular shape, etc.), the measurement at its greatest width or thickness applies.

Steel products included in the scope of this investigation are products in which: (1) iron predominates, by weight, over each of the other contained elements; and (2) the carbon content is 2 percent or less, by weight.

Subject merchandise also includes corrosion-resistant steel that has been further processed in a third country, including but not limited to annealing, tempering, painting, varnishing, trimming, cutting, punching and/or slitting or any other processing that would not otherwise remove the merchandise from the scope of the investigation if performed in the country of manufacture of the in-scope corrosion resistant steel.

All products that meet the written physical description are within the scope of this investigation unless specifically excluded. The following products are outside of and/or specifically excluded from the scope of this investigation:

- Flat-rolled steel products either plated or coated with tin, lead, chromium, chromium oxides, both tin and lead (“tème plate”) or both chromium and chromium oxides (“tin free steel”), whether or not painted, varnished or coated with plastics or other non-metallic substances in addition to the metallic coating;

- Clad products in straight lengths of 4.7625 mm or more in composite thickness and of a width which exceeds 150 mm and measures at least twice the thickness;

- Certain clad stainless flat-rolled products, which are three-layered corrosion-resistant carbon steel flat-rolled products less than 4.75 mm in composite thickness that consist of a carbon steel flat-rolled product clad on both sides with stainless steel in a 20%–60%–20% ratio; and

Also excluded from the scope of the antidumping duty investigation on corrosion resistant steel from Taiwan are any products covered by the existing antidumping duty order on corrosion-resistant steel from Taiwan. See *Certain Corrosion-Resistant*

Steel Products from India, Italy, the People’s Republic of China, the Republic of Korea and Taiwan: Amended Final Affirmative Antidumping Determination for India and Taiwan, and Antidumping Duty Orders, 81 FR 48390 (July 25, 2016); *Corrosion-Resistant Steel Products from Taiwan: Notice of Third Amended Final Determination of Sales at Less Than Fair Value Pursuant to Court Decision and Partial Exclusion from Antidumping Duty Order*, 88 FR 58245 (August 25, 2023).

The products subject to the investigation are currently classified in the Harmonized Tariff Schedule of the United States (HTSUS) under item numbers: 7210.30.0030, 7210.30.0060, 7210.41.0000, 7210.49.0030, 7210.49.0040, 7210.49.0045, 7210.49.0091, 7210.49.0095, 7210.61.0000, 7210.69.0000, 7210.70.6030, 7210.70.6060, 7210.70.6090, 7210.90.6000, 7210.90.9000, 7212.20.0000, 7212.30.1030, 7212.30.1090, 7212.30.3000, 7212.49.5000, 7212.61.0000, 7212.40.5000, 7212.50.0000, 7212.60.0000, 7225.91.0000, 7225.92.0000, 7226.99.0110, and 7226.99.0130.

The products subject to the investigation may also enter under the following HTSUS item numbers: 7210.90.1000, 7215.90.1000, 7215.90.3000, 7215.90.5000, 7217.20.1500, 7217.30.1530, 7217.30.1560, 7217.90.1000, 7217.90.5030, 7217.90.5060, 7217.90.5090, 7225.99.0090, 7226.99.0180, 7228.60.6000, 7228.60.8000, and 7229.90.1000.

The HTSUS subheadings above are provided for convenience and customs purposes only. The written description of the scope of the investigations is dispositive.

Appendix II—List of Topics Discussed in the Preliminary Decision Memorandum

- I. Summary
- II. Background
- III. Period of Investigation
- IV. Use of Facts Available and Adverse Inferences
- V. Discussion of the Methodology
- VI. Currency Conversion
- VII. Recommendation

[FR Doc. 2025–06139 Filed 4–9–25; 8:45 am]

BILLING CODE 3510–DS–P

DEPARTMENT OF ENERGY

Federal Energy Regulatory Commission

[Docket No. CP24–490–000]

EcoEléctrica L.P.; Notice of Availability of the Environmental Assessment for the Proposed Ecoelétrica LNG Supply Pipeline Capacity Project

The staff of the Federal Energy Regulatory Commission (FERC or Commission) has prepared an environmental assessment (EA) for the EcoEléctrica LNG Supply Pipeline Capacity Project (Project) proposed by EcoEléctrica L.P. (EcoEléctrica) in the

above-referenced docket.¹ EcoEléctrica proposes to increase the existing LNG Supply Pipeline Project send out capacity between the Liquefied Natural Gas (LNG) terminal in Peñuelas, Puerto Rico and the off-site, non-jurisdictional Crowley Puerto Rico LLC Truck Loading Facility (TLF) from 250 gallons per minute (gpm) to 500 gpm. The Project entails adjusting software pressure and flow control setpoints to allow for the increased flow of LNG at the inlet of the LNG Supply Pipeline. EcoEléctrica states that the purpose of the project is to satisfy the increasing demand for LNG from the TLF and its downstream users in Puerto Rico.

The EA assesses the potential environmental effects of the Project in accordance with the requirements of the National Environmental Policy Act. The FERC staff concludes that approval of the proposed project would not constitute a major federal action significantly affecting the quality of the human environment.

The U.S. Coast Guard and the U.S. Department of Transportation participated as cooperating agencies in the preparation of the EA. Cooperating agencies have jurisdiction by law or special expertise with respect to resources potentially affected by the proposal and participate in the NEPA analysis.

The Commission mailed a copy of the *Notice of Availability* of the EA to federal, state, and local government representatives and agencies; elected officials; environmental and public interest groups; potentially affected landowners and other interested individuals and groups. The EA is only available in electronic format. It may be viewed and downloaded from the FERC’s website (www.ferc.gov), on the natural gas environmental documents page (<https://www.ferc.gov/industries-data/natural-gas/environmental/environmental-documents>). In addition, the EA may be accessed by using the eLibrary link on the FERC’s website. Click on the eLibrary link (<https://elibrary.ferc.gov/eLibrary/search>), select “General Search” and enter the docket number in the “Docket Number” field (i.e. CP24–490–000). Be sure you have selected an appropriate date range. For assistance, please contact FERC Online Support at FercOnlineSupport@ferc.gov or toll free at (866) 208–3676, or for TTY, contact (202) 502–8659.

The EA is not a decision document. It presents Commission staff’s

¹ For tracking purposes under the National Environmental Policy Act, the unique identification number for documents relating to this environmental review is EAXX–019–20–000–1730221396.

independent analysis of the environmental issues for the Commission to consider when addressing the merits of all issues in this proceeding. Any person wishing to comment on the EA may do so. Your comments should focus on the EA's disclosure and discussion of potential environmental effects, reasonable alternatives, and measures to avoid or lessen environmental impacts. The more specific your comments, the more useful they will be. To ensure that the Commission has the opportunity to consider your comments prior to making its decision on this project, it is important that we receive your comments in Washington, DC on or before 5 p.m. Eastern Time on May 5, 2025.

For your convenience, there are three methods you can use to file your comments to the Commission. The Commission encourages electronic filing of comments and has staff available to assist you at (866) 208-3676 or FercOnlineSupport@ferc.gov. Please carefully follow these instructions so that your comments are properly recorded.

(1) You can file your comments electronically using the eComment feature on the Commission's website (www.ferc.gov) under the link to FERC Online. This is an easy method for submitting brief, text-only comments on a project;

(2) You can also file your comments electronically using the eFiling feature on the Commission's website (www.ferc.gov) under the link to FERC Online. With eFiling, you can provide comments in a variety of formats by attaching them as a file with your submission. New eFiling users must first create an account by clicking on "eRegister." You must select the type of filing you are making. If you are filing a comment on a particular project, please select "Comment on a Filing"; or

(3) You can file a paper copy of your comments by mailing them to the Commission. Be sure to reference the project docket number (CP24-490-000) on your letter. Submissions sent via the U.S. Postal Service must be addressed to: Debbie-Anne A. Reese, Secretary, Federal Energy Regulatory Commission, 888 First Street NE, Room 1A, Washington, DC 20426. Submissions sent via any other carrier must be addressed to: Debbie-Anne A. Reese, Secretary, Federal Energy Regulatory Commission, 12225 Wilkins Avenue, Rockville, Maryland 20852.

Filing environmental comments will not give you intervenor status, but you do not need intervenor status to have your comments considered. Only

intervenors have the right to seek rehearing or judicial review of the Commission's decision. At this point in this proceeding, the timeframe for filing timely intervention requests has expired. Any person seeking to become a party to the proceeding must file a motion to intervene out-of-time pursuant to Rule 214(b)(3) and (d) of the Commission's Rules of Practice and Procedures (18 CFR 385.214(b)(3) and (d)) and show good cause why the time limitation should be waived. Motions to intervene are more fully described at <https://www.ferc.gov/how-intervene>.

Additional information about the project is available from the Commission's Office of External Affairs, at (866) 208-FERC, or on the FERC website (www.ferc.gov) using the eLibrary link. The eLibrary link also provides access to the texts of all formal documents issued by the Commission, such as orders, notices, and rulemakings.

The Commission's Office of Public Participation (OPP) supports meaningful public engagement and participation in Commission proceedings. OPP can help members of the public, including landowners, community organizations, Tribal members and others, access publicly available information and navigate Commission processes. For public inquiries and assistance with making filings such as interventions, comments, or requests for rehearing, the public is encouraged to contact OPP at (202) 502-6595 or OPP@ferc.gov.

In addition, the Commission offers a free service called eSubscription which allows you to keep track of all formal issuances and submittals in specific dockets. This can reduce the amount of time you spend researching proceedings by automatically providing you with notification of these filings, document summaries, and direct links to the documents. Go to <https://www.ferc.gov/ferc-online/overview> to register for eSubscription.

Dated: April 4, 2025.

Debbie-Anne A. Reese,
Secretary.

[FR Doc. 2025-06153 Filed 4-9-25; 8:45 am]

BILLING CODE 6717-01-P

DEPARTMENT OF ENERGY

Federal Energy Regulatory Commission

[Project No. 1975-131]

Idaho Power Company; Notice of Effectiveness of Withdrawal of Application for Amendment of License

On December 6, 2024, Idaho Power Company (licensee) filed an application for a non-capacity amendment for the Bliss Project No. 1975.¹ On March 18, 2025, the licensee filed a notice of withdrawal of the request. The project is located on the Snake River in Gooding, Twin Falls, and Elmore Counties, Idaho. Part of the project occupies federal lands managed by the Bureau of Land Management.

No motion in opposition to the notice of withdrawal has been filed, and the Commission has taken no action to disallow the withdrawal. Pursuant to Rule 216(b) of the Commission's Rules of Practice and Procedure,² the withdrawal of the application became effective on April 3, 2025, and this proceeding is hereby terminated.

Dated: April 4, 2025.

Debbie-Anne A. Reese,
Secretary.

[FR Doc. 2025-06152 Filed 4-9-25; 8:45 am]

BILLING CODE 6717-01-P

DEPARTMENT OF ENERGY

Federal Energy Regulatory Commission

Combined Notice of Filings #1

Take notice that the Commission received the following electric rate filings:

Docket Numbers: ER25-1875-000.

Applicants: California Independent System Operator Corporation.

Description: § 205(d) Rate Filing: 2025-04-03 2025 Spring Tariff Clarification Filing to be effective 6/3/2025.

Filed Date: 4/3/25.

Accession Number: 20250403-5169.

Comment Date: 5 p.m. ET 4/24/25.

Docket Numbers: ER25-1876-000.

Applicants: Southwest Power Pool, Inc.

Description: Tariff Amendment: 3906 Wedington Solar GIA Cancellation to be effective 6/25/2025.

Filed Date: 4/4/25.

Accession Number: 20250404-5020.

¹ *Idaho Power Company*, 108 FERC ¶ 61,128 (2004).

² 18 CFR 385.216(b) (2024).

Comment Date: 5 p.m. ET 4/25/25.
Docket Numbers: ER25–1878–000.
Applicants: Omaha Public Power District, Southwest Power Pool, Inc.
Description: § 205(d) Rate Filing: Omaha Public Power District submits tariff filing per 35.13(a)(2)(iii): Omaha Public Power District Formula Rate Revisions to be effective 1/1/2026.
Filed Date: 4/4/25.
Accession Number: 20250404–5087.
Comment Date: 5 p.m. ET 4/25/25.
Docket Numbers: ER25–1879–000.
Applicants: PJM Interconnection, L.L.C.
Description: § 205(d) Rate Filing: Original GIA Service Agreement No. 7612; Project Identifier No. AF2–107 to be effective 3/5/2025.
Filed Date: 4/4/25.
Accession Number: 20250404–5100.
Comment Date: 5 p.m. ET 4/25/25.
Docket Numbers: ER25–1880–000.
Applicants: PJM Interconnection, L.L.C.
Description: § 205(d) Rate Filing: Original GIA Service Agreement No. 7616; Project Identifier No. AG1–368 to be effective 3/5/2025.
Filed Date: 4/4/25.
Accession Number: 20250404–5104.
Comment Date: 5 p.m. ET 4/25/25.
Docket Numbers: ER25–1881–000.
Applicants: Southern California Edison Company.
Description: Tariff Amendment: Terminate GIA & DSA, PPA Grand Johanna (WDT1406/SA Nos. 925–926) to be effective 4/7/2025.
Filed Date: 4/4/25.
Accession Number: 20250404–5106.
Comment Date: 5 p.m. ET 4/25/25.
Docket Numbers: ER25–1882–000.
Applicants: PJM Interconnection, L.L.C.
Description: § 205(d) Rate Filing: Original GIA, Service Agreement No. 7633; Project Identifier No. AG1–067 to be effective 6/7/2025.
Filed Date: 4/4/25.
Accession Number: 20250404–5144.
Comment Date: 5 p.m. ET 4/25/25.
Docket Numbers: ER25–1883–000.
Applicants: PJM Interconnection, L.L.C.
Description: § 205(d) Rate Filing: Original CSA Service Agreement No. 7622; Project Identifier No. AG1–368 to be effective 3/14/2025.
Filed Date: 4/4/25.
Accession Number: 20250404–5149.
Comment Date: 5 p.m. ET 4/25/25.
Docket Numbers: ER25–1884–000.
Applicants: Louisville Gas and Electric Company.
Description: § 205(d) Rate Filing: KYMEA Engineering and Procurement

Agreement S.A. No. 27 to be effective 4/3/2025.

Filed Date: 4/4/25.

Accession Number: 20250404–5156.

Comment Date: 5 p.m. ET 4/25/25.

Docket Numbers: ER25–1885–000.

Applicants: PJM Interconnection, L.L.C.

Description: § 205(d) Rate Filing: Original GIA SA No. 7617; AC2–176/AG1–017, Cancellation ISA No. 5466; AC2–176 to be effective 3/5/2025.

Filed Date: 4/4/25.

Accession Number: 20250404–5167.

Comment Date: 5 p.m. ET 4/25/25.

The filings are accessible in the Commission's eLibrary system (<https://elibrary.ferc.gov/idmws/search/fercensearch.asp>) by querying the docket number.

Any person desiring to intervene, to protest, or to answer a complaint in any of the above proceedings must file in accordance with Rules 211, 214, or 206 of the Commission's Regulations (18 CFR 385.211, 385.214, or 385.206) on or before 5:00 p.m. Eastern time on the specified comment date. Protests may be considered, but intervention is necessary to become a party to the proceeding.

eFiling is encouraged. More detailed information relating to filing requirements, interventions, protests, service, and qualifying facilities filings can be found at: <http://www.ferc.gov/docs-filing/efiling/filing-req.pdf>. For other information, call (866) 208–3676 (toll free). For TTY, call (202) 502–8659.

The Commission's Office of Public Participation (OPP) supports meaningful public engagement and participation in Commission proceedings. OPP can help members of the public, including landowners, community organizations, Tribal members and others, access publicly available information and navigate Commission processes. For public inquiries and assistance with making filings such as interventions, comments, or requests for rehearing, the public is encouraged to contact OPP at (202) 502–6595 or OPP@ferc.gov.

Dated: March 4, 2025.

Carlos D. Clay,

Deputy Secretary.

[FR Doc. 2025–06155 Filed 4–9–25; 8:45 am]

BILLING CODE 6717–01–P

DEPARTMENT OF ENERGY

Federal Energy Regulatory Commission

Combined Notice of Filings

Take notice that the Commission has received the following Natural Gas Pipeline Rate and Refund Report filings:

Filings Instituting Proceedings

Docket Numbers: RP25–814–000.
Applicants: Tennessee Gas Pipeline Company, L.L.C.

Description: § 4(d) Rate Filing: Revised Penalty Crediting Language to be effective 5/1/2025.

Filed Date: 4/4/25.

Accession Number: 20250404–5000.

Comment Date: 5 p.m. ET 4/16/25.

Docket Numbers: RP25–815–000.

Applicants: NEXUS Gas Transmission, LLC.

Description: § 4(d) Rate Filing: Negotiated Rates—CNX to Spire eff 4–4–25 to be effective 4/4/2025.

Filed Date: 4/4/25.

Accession Number: 20250404–5054.

Comment Date: 5 p.m. ET 4/16/25.

Any person desiring to intervene, to protest, or to answer a complaint in any of the above proceedings must file in accordance with Rules 211, 214, or 206 of the Commission's Regulations (18 CFR 385.211, 385.214, or 385.206) on or before 5:00 p.m. Eastern time on the specified comment date. Protests may be considered, but intervention is necessary to become a party to the proceeding.

Filings in Existing Proceedings

Docket Numbers: RP25–497–001.
Applicants: Stingray Pipeline Company, L.L.C.

Description: Compliance filing: NAESB Version 4.0 Compliance—Corrected to be effective 8/1/2025.

Filed Date: 4/3/25.

Accession Number: 20250403–5126.

Comment Date: 5 p.m. ET 4/15/25.

Docket Numbers: RP25–666–001.

Applicants: Midship Pipeline Company, LLC.

Description: Compliance filing: Midship Pipeline Revised Change of Address Filing to be effective 4/1/2025.

Filed Date: 4/3/25.

Accession Number: 20250403–5174.

Comment Date: 5 p.m. ET 4/15/25.

Any person desiring to protest in any of the above proceedings must file in accordance with Rule 211 of the Commission's Regulations (18 CFR 385.211) on or before 5:00 p.m. Eastern time on the specified comment date.

The filings are accessible in the Commission's eLibrary system (<https://>

elibrary.ferc.gov/idmws/search/fercgensearch.asp by querying the docket number.

eFiling is encouraged. More detailed information relating to filing requirements, interventions, protests, service, and qualifying facilities filings can be found at: <http://www.ferc.gov/docs-filing/efiling/filing-req.pdf>. For other information, call (866) 208-3676 (toll free). For TTY, call (202) 502-8659.

The Commission's Office of Public Participation (OPP) supports meaningful public engagement and participation in Commission proceedings. OPP can help members of the public, including landowners, community organizations, Tribal members and others, access publicly available information and navigate Commission processes. For public inquiries and assistance with making filings such as interventions, comments, or requests for rehearing, the public is encouraged to contact OPP at (202) 502-6595 or OPP@ferc.gov.

Dated: April 4, 2025.

Carlos D. Clay,

Deputy Secretary.

[FR Doc. 2025-06156 Filed 4-9-25; 8:45 am]

BILLING CODE 6717-01-P

EXPORT-IMPORT BANK

[Public Notice: 2025-6002]

Agency Information Collection Activities: Submission to the Office of Management and Budget for Review and Approval; Comment Request; EIB 10-06, Application for Approved Finance Provider

AGENCY: Export-Import Bank of the United States.

ACTION: Submission for OMB review and comments request.

SUMMARY: The Export-Import Bank of the United States (EXIM), as part of its continuing effort to reduce paperwork and respondent burden, invites the general public and other Federal Agencies to comment on the proposed information collection, as required by the Paperwork Reduction Act of 1995.

DATES: Comments must be received on or before June 9, 2025 to be assured of consideration.

ADDRESSES: Comments may be submitted electronically on WWW.REGULATIONS.GOV (EIB 10-06), by email to Donna.Schneider@exim.gov, or by mail to Donna Schneider, Export-Import Bank, 811 Vermont Ave. NW, Washington, DC 20571.

The information collection tool can be reviewed at: <https://img.exim.gov/s3fs->

public/pub/pending/EIB10-06+Application+for+Approved+Finance+Provider.pdf.

FOR FURTHER INFORMATION CONTACT: To request additional information, please contact Donna Schneider, donna.schneider@exim.gov, 202-565-3612.

SUPPLEMENTARY INFORMATION: An AFP may participate in the Medium-Term Insurance, Bank Letter of Credit, and Financial Institution Buyer Credit programs as an insured lender, while AFPs approved for an MGA may apply for multiple loan or lease transactions to be guaranteed by EXIM. EXIM uses the information provided in the form and the supplemental information required to be submitted with the form to determine whether the lender qualifies to participate in its lender insurance and guarantee programs. The details are necessary to evaluate whether the lender has the capital to fund potential transactions, proper due diligence procedures, and the monitoring capacity to carry out transactions.

Title and Form Number: EIB 10-06 Application for Approved Finance Provider.

OMB Number: 3048-0032.

Type of Review: Regular.

Need and Use: The information collected will allow EXIM to determine compliance and content for transaction requests submitted to the Export-Import Bank under its insurance, guarantee, and direct loan programs. Financial institutions interested in becoming an Approved Finance Provider (AFP) with EXIM must complete this application in order to obtain approval to make loans under EXIM insurance policies and/or enter into one or more Master Guarantee Agreements (MGA) with EXIM.

Affected Public: This form affects entities involved in the export of U.S. goods and services.

Annual Number of Respondents: 50.

Estimated Time per Respondent: 30 minutes.

Annual Burden Hours: 25 hours.

Frequency of Reporting of Use: On occasion.

Dated: April 7, 2025.

Andrew Smith,

Records Officer.

[FR Doc. 2025-06151 Filed 4-9-25; 8:45 am]

BILLING CODE 6690-01-P

EXPORT-IMPORT BANK

[Public Notice: 2025-6001]

Agency Information Collection Activities: Submission to the Office of Management and Budget for Review and Approval; Comment Request; EIB 99-14, Export-Import Bank Trade Reference Form

AGENCY: Export-Import Bank of the United States.

ACTION: Submission for OMB review and comments request.

SUMMARY: The Export-Import Bank of the United States (EXIM), pursuant to the Export-Import Bank Act of 1945, as amended facilitates the finance of the export of U.S. goods and services. As part of its continuing effort to reduce paperwork and respondent burden, EXIM invites the general public and other Federal agencies to comment on the proposed information collection, as required by the Paperwork Reduction Act of 1995.

DATES: Comments should be received on or before June 9, 2025 to be assured of consideration.

ADDRESSES: Comments may be submitted electronically on WWW.REGULATIONS.GOV (EIB 99-14), by email edward.coppola@exim.gov, or by mail to Edward Coppola, Export-Import Bank of the United States, 811 Vermont Ave. NW, Washington, DC 20571. The form can be viewed at https://img.exim.gov/s3fs-public/pub/pending/eib99-14_1REV_508.pdf.

FOR FURTHER INFORMATION CONTACT: To request additional information, please contact Edward Coppola edward.coppola@exim.gov, 202-565-3717.

SUPPLEMENTARY INFORMATION:

Titles and Form Number: EIB 99-14 Export-Import Bank Trade Reference form.

OMB Number: 3048-0042.

Type of Review: Regular.

Need and Use: This collection of information is necessary, pursuant to 12 U.S.C. 635(a)(1), to determine whether or not a company has a good payment history. This form will enable EXIM to make a credit decision on a foreign buyer credit limit request submitted by a new or existing policy holder. Additionally, this form is used by those EXIM policy holders granted delegated authority to commit the Bank to a foreign buyer credit limit. The form provides essential credit information used by EXIM credit officers when analyzing requests for export credit

insurance/financing support, both short-term (360 days and less) and medium-term (longer than 360 days), for the export of their U.S. goods and services. This form is an integral part of the short-term multi-buyer export credit insurance policy for those policy holders granted foreign buyer discretionary credit limit authority (DCL). Multi-Buyer policy holders given DCL authority may use this form as the sole source or one piece among several sources of credit information for their internal foreign buyer credit decision which, in turn, commits EXIM's insurance.

Affected Public: This form affects entities involved in the export of U.S. goods and services.

Annual Number of Respondents: 6,500.

Estimated Time per Respondent: 15 minutes.

Annual Burden Hours: 1,625 hours.

Frequency of Reporting or Use: As needed.

Dated: April 7, 2025.

Andrew Smith,
Records Officer.

[FR Doc. 2025-06150 Filed 4-9-25; 8:45 am]

BILLING CODE 6690-01-P

FEDERAL ELECTION COMMISSION

[NOTICE 2025-03]

Notice of Designation of Policy-Making Positions

AGENCY: Federal Election Commission.

ACTION: Notice of designation of policy-making positions.

SUMMARY: As mandated by an executive order, the Federal Election Commission (the "Commission") is designating certain positions as the Agency's confidential, policy-determining, policy-making, or policy-advocating positions. Additional details appear in the Supplemental Information that follows.

DATES: April 10, 2025.

ADDRESSES: 1050 First Street NE, Washington, DC 20463.

FOR FURTHER INFORMATION CONTACT: Greg Baker, Office of General Counsel, 1050 First Street NE, Washington, DC 20463, (202) 694-1650 or (800) 424-9530.

SUPPLEMENTARY INFORMATION: On January 20, 2025, the President issued Executive Order 14171 (90 FR 8625 (Jan. 31, 2025)), reinstating and amending Executive Order 13957. 85 FR 67631 (Oct. 21, 2020). The latter, as amended, directs agencies to conduct a review of agency positions and, "for positions

excepted from the competitive service by statute, determine which such positions are of a confidential, policy-determining, policy-making, or policy-advocating character and are not normally subject to change as a result of a Presidential transition." *Id.* at 67633. Agencies were further directed to "publish this determination in the **Federal Register.**" *Id.*

Accordingly, the Commission is designating the following positions as the Agency's confidential, policy-determining, policy-making, or policy-advocating positions, under the definition presumed by Executive Order 14171: the Staff Director, the General Counsel, the Inspector General, and the Director of Congressional and Intergovernmental Affairs.

On behalf of the Commission,

Dated: April 3, 2025.

On behalf of the Commission.

James E. Trainor,
Acting Chairman, Federal Election Commission.

[FR Doc. 2025-06112 Filed 4-9-25; 8:45 am]

BILLING CODE 6715-01-P

DEPARTMENT OF HEALTH AND HUMAN SERVICES

National Institutes of Health

National Institute of Allergy and Infectious Diseases; Notice of Closed Meeting

Pursuant to section 1009 of the Federal Advisory Committee Act, as amended, notice is hereby given of the following meeting.

The meeting will be closed to the public in accordance with the provisions set forth in sections 552b(c)(4) and 552b(c)(6), Title 5 U.S.C., as amended. The grant applications and the discussions could disclose confidential trade secrets or commercial property such as patentable material, and personal information concerning individuals associated with the grant applications, the disclosure of which would constitute a clearly unwarranted invasion of personal privacy.

Name of Committee: National Institute of Allergy and Infectious Diseases Special Emphasis Panel; Engineering Durable HIV Vaccine Protection (ENDURE) (R01 Clinical Trial Not Allowed).

Date: May 13-14, 2025.

Time: 10:00 a.m. to 5:00 p.m.

Agenda: To review and evaluate grant applications.

Address: National Institute of Allergy and Infectious Diseases, National Institutes of Health, 5601 Fishers Lane, Room 3G21B, Rockville, MD 20892.

Meeting Format: Video Assisted Meeting.
Contact Person: Robert C. Unfer, Ph.D., Scientific Review Officer, Scientific Review Program, National Institute of Allergy and Infectious Diseases, National Institutes of Health, 5601 Fishers Lane, Room 3G21B, Rockville, MD 20892, 240-669-5035, unferrc@nih.gov.

(Catalogue of Federal Domestic Assistance Program Nos. 93.855, Allergy, Immunology, and Transplantation Research; 93.856, Microbiology and Infectious Diseases Research, National Institutes of Health, HHS)

Dated: April 7, 2025.

Melanie J. Pantoja,
Program Analyst, Office of Federal Advisory Committee Policy.

[FR Doc. 2025-06149 Filed 4-9-25; 8:45 am]

BILLING CODE 4140-01-P

INTERNATIONAL TRADE COMMISSION

[Investigation Nos. 731-TA-1422-1423 (Review)]

Strontium Chromate From Austria and France

Determinations

On the basis of the record¹ developed in the subject five-year reviews, the United States International Trade Commission ("Commission") determines, pursuant to the Tariff Act of 1930 ("the Act"), that revocation of the antidumping duty orders on strontium chromate from Austria and France would be likely to lead to continuation or recurrence of material injury to an industry in the United States within a reasonably foreseeable time.

Background

The Commission instituted these reviews on October 1, 2024 (89 FR 79947) and determined on January 6, 2025 that it would conduct expedited reviews (90 FR 8141, January 24, 2025).

The Commission made these determinations pursuant to section 751(c) of the Act (19 U.S.C. 1675(c)). It completed and filed its determinations in these reviews on April 4, 2025. The views of the Commission are contained in USITC Publication 5605 (April 2025), entitled *Strontium Chromate from Austria and France: Investigation Nos. 731-TA-1422-1423 (Review)*.

By order of the Commission.

Issued: April 4, 2025.

Lisa Barton,

Secretary to the Commission.

[FR Doc. 2025-06109 Filed 4-9-25; 8:45 am]

BILLING CODE 7020-02-P

¹ The record is defined in § 207.2(f) of the Commission's Rules of Practice and Procedure (19 CFR 207.2(f)).

DEPARTMENT OF LABOR**Bureau of Labor Statistics****Information Collection Activities;
Comment Request**

AGENCY: Bureau of Labor Statistics, Department of Labor.

ACTION: Notice of information collection; request for comment.

SUMMARY: The Department of Labor, as part of its continuing effort to reduce paperwork and respondent burden, conducts a pre-clearance consultation program to provide the general public and Federal agencies with an opportunity to comment on proposed and/or continuing collections of information in accordance with the Paperwork Reduction Act of 1995. This program helps to ensure that requested data can be provided in the desired format, reporting burden (time and financial resources) is minimized, collection instruments are clearly understood, and the impact of collection requirements on respondents can be properly assessed. The Bureau of Labor Statistics (BLS) is soliciting comments concerning the proposed extension of the “Census of Fatal Occupational Injuries.” A copy of the proposed information collection request can be obtained by contacting the individual listed below in the **ADDRESSES** section of this notice.

DATES: Written comments must be submitted to the office listed in the **ADDRESSES** section of this notice on or before June 9, 2025.

ADDRESSES: Send comments to Nora Kincaid, BLS Clearance Officer, Division of Management Systems, Bureau of Labor Statistics, by email to BLS_PRA_Public@bls.gov.

FOR FURTHER INFORMATION CONTACT: Nora Kincaid, BLS Clearance Officer, at 202-691-7628 (this is not a toll-free number). (See **ADDRESSES** section.)

SUPPLEMENTARY INFORMATION:**I. Background**

The Bureau of Labor Statistics (BLS) was delegated responsibility by the Secretary of Labor for implementing Section 24(a) of the Occupational Safety and Health Act of 1970. This section states that “the Secretary shall compile accurate statistics on work injuries and illnesses which shall include all disabling, serious, or significant injuries and illnesses . . .”

Prior to the implementation of the Census of Fatal Occupational Injuries (CFOI), the BLS generated estimates of occupational fatalities for private sector employers from a sample survey of

about 280,000 establishments. Studies showed that occupational fatalities were underreported in those estimates as well as in those compiled by regulatory, vital statistics, and workers’ compensation systems. Estimates prior to the CFOI varied widely, ranging from 3,000 to 10,000 fatal work injuries annually. In addition, information needed to develop prevention strategies were often missing from these earlier programs.

In the late 1980s, the National Academy of Sciences study, *Counting Injuries and Illnesses in the Workplace*, and another report, *Keystone National Policy Dialogue on Work-Related Illness and Injury Recordkeeping*, emphasized the need for the BLS to compile a complete roster of work-related fatalities because of concern over the accuracy of using a sample survey to estimate the incidence of occupational fatalities. These studies also recommended the use of all available data sources to compile detailed information for fatality prevention efforts.

The BLS tested the feasibility of collecting fatality data in this manner in 1989 and 1990. The resulting CFOI was implemented in 32 states in 1991. National data covering all 50 states, New York City, the District of Columbia, and three U.S. Territories have been compiled and published annually since 1992.

The CFOI compiles comprehensive, accurate, and timely information on fatal work injuries needed to develop effective prevention strategies. The system collects information concerning the incident, demographic information of the deceased, and characteristics of the employer.

CFOI data are used to:

- Develop employee safety training programs.
- Develop and assess the effectiveness of safety standards.
- Conduct research for developing prevention strategies.

In addition, state partners use the data to publish state reports, to identify state-specific hazards, to allocate resources for promoting safety in the workplace, and to evaluate the quality of work life in the state.

II. Current Action

Office of Management and Budget clearance is being sought for the Census of Fatal Occupational Injuries.

In 2023, 5,283 workers lost their lives because of fatal work injuries. This official systematic, verifiable count mutes controversy over the various counts from different sources. The CFOI count has been adopted by the National Safety Council and other organizations as the sole source of a comprehensive

count of fatal work injuries for the U.S. If this information were not collected, confusion over the number and patterns in fatal occupational injuries would hamper prevention efforts. By providing timely occupational fatality data, the CFOI provides safety and health managers the information necessary to respond to emerging workplace hazards.

During 2024, the BLS national office responded to 88 requests for CFOI data from various organizations. (This figure excludes requests received by states for state-specific data.) In addition, the CFOI page of the BLS website averaged about 8,084 users per month in 2024.

National office staff also responded to numerous requests from safety organizations for staff members to participate in safety conferences and seminars. The CFOI research file, made available to safety and health groups, is being used by 4 organizations. Study topics include fatalities by worker demographic category (young workers, older workers, Hispanic workers); by occupation or industry (construction workers, police officers, firefighters, landscaping workers, workers in oil and gas extraction); by event (heat-related fatalities, fatalities from workplace violence, suicides, falls from height); or other research such as safety and health program effectiveness and the impact of fatality risk on wages. A current list of research articles and reports that include CFOI data can be found at: <https://www.bls.gov/iif/publications-overview.htm>.

III. Desired Focus of Comments

The Bureau of Labor Statistics is particularly interested in comments that:

- Evaluate whether the proposed collection of information is necessary for the proper performance of the functions of the agency, including whether the information will have practical utility.
- Evaluate the accuracy of the agency’s estimate of the burden of the proposed collection of information, including the validity of the methodology and assumptions used.
 - Enhance the quality, utility, and clarity of the information to be collected.
 - Minimize the burden of the collection of information on those who are to respond, including through the use of appropriate automated, electronic, mechanical, or other technological collection techniques or other forms of information technology, e.g., permitting electronic submissions of responses.

Title of Collection: Census of Fatal Occupational Injuries.

OMB Number: 1220–0133.
Type of Review: Extension.

Affected Public: Federal government; Individuals or households; Private sector (Business or other for-profits,

Not-for-profit institutions, Farms); State, local, or tribal governments.

Form	Total respondents	Frequency	Total responses	Average time per response (minutes)	Estimated total burden (hours)
Form BLS CFOI–1	205	On Occasion	205	20	69
Source Documents	227	On Occasion	15,867	10	2,713
Totals	432	16,072	2,782

Comments submitted in response to this notice will be summarized and/or included in the request for Office of Management and Budget approval of the information collection request; they also will become a matter of public record.

Signed at Washington, DC, on April 3, 2025.

Eric Molina,

Chief, Division of Management Systems, Branch of Policy Analysis.

[FR Doc. 2025–06124 Filed 4–9–25; 8:45 am]

BILLING CODE 4510–24–P

POSTAL REGULATORY COMMISSION

[Docket No. IM2025–1; Order No. 8773]

Section 407 Proceeding

AGENCY: Postal Regulatory Commission.

ACTION: Notice.

SUMMARY: The Commission is establishing a docket to solicit comments for the purpose of developing its views on whether certain proposals for the upcoming UPU Congress are consistent with the standards and criteria for modern rate regulation established by the Commission under applicable sections of the United States Code. This notice informs the public of the filing, invites public comment, and takes other administrative steps.

DATES: *Comments are due:* June 6, 2025.

ADDRESSES: Submit comments electronically via the Commission’s Filing Online system at <https://www.prc.gov>. Those who cannot submit comments electronically should contact the person identified in the **FOR FURTHER INFORMATION CONTACT** section by telephone for advice on filing alternatives.

FOR FURTHER INFORMATION CONTACT: David A. Trissell, General Counsel, at 202–789–6820.

SUPPLEMENTARY INFORMATION:

Table of Contents

- I. Introduction
- II. Initial Commission Action

III. Ordering Paragraphs

I. Introduction

The 28th Universal Postal Union (UPU) Congress will take place September 7–20, 2025, in the United Arab Emirates. Before the United States concludes any treaty, convention, or amendment that establishes a Market Dominant rate or classification, the Secretary of State must request that the Commission provide views on whether such treaties, conventions, or amendments are consistent with the standards and criteria for modern rate regulation established by the Commission under 39 U.S.C. 3622. 39 U.S.C. 407(c)(1). On March 31, 2025, the Department of State requested the Commission’s views on relevant proposals that will be presented at the 28th UPU Congress.¹

Pursuant to section 407(c)(1) and 39 CFR part 3025, the Commission establishes Docket No. IM2025–1 for the purpose of developing its views on whether certain proposals for the upcoming UPU Congress are consistent with the standards and criteria for modern rate regulation established by the Commission under 39 U.S.C. 3622.

II. Initial Commission Action

Establishment of docket. Part 3025 of title 39 of the Code of Federal Regulations codifies procedures related to the development of the Commission’s section 407 views.² Pursuant to rule

¹ Letter from A. McCoy Pitt, Senior Bureau Official, U.S. Department of State, Bureau of International Organization Affairs, March 31, 2025 (State’s Request).

² See Docket No. RM2015–14, Order Adopting Final Rules on Procedures Related to Commission Views, December 30, 2015 (Order No. 2960). See also 81 FR 869 (January 8, 2016). The rules relating to views were codified in part 3017 and took effect on February 8, 2016. The Commission later revised these rules to enhance transparency and accountability within the Commission view process and improve public accessibility to related documents. Docket No. RM2020–3, Order Adopting Final Rules Related to Commission Views, February 24, 2020, at 1–2 (Order No. 5439). These revised rules went into effect on April 21, 2020. Order No. 5439 at 5. Subsequently, the Commission issued a final rulemaking in a separate proceeding that, among other things, renumbered several parts in

3025.103(c), the Commission establishes this docket to solicit public comments on “the specific relevant proposals posted by the Commission and the general principles that should guide the development of Commission views as well as any other materials posted in the applicable docket . . .” 39 CFR 3025.103(c).

Comments. Rule 3025.104(a) provides that the Commission “shall establish a deadline for comments upon establishment of the docket that is consistent with timely submission of Commission views to the Secretary of State.” 39 CFR 3025.104(a). The 28th Universal Postal Union Congress will take place September 7–20, 2025, in the United Arab Emirates. The Department of State requests that the Commission submit its views by August 5, 2025. State’s Request at 1. To ensure timely submission of the Commission’s views to the Department of State, the Commission establishes June 6, 2025 as the deadline for submission of comments on the consistency of the specific relevant proposals posted by the Commission that are subject to subchapter I of chapter 36 with the standards and criteria established by the Commission under 39 U.S.C. 3622, and the general principles that should guide the development of Commission views as well as any other materials posted in this docket.

Using the Commission’s Filing Online System. Except as provided in 39 CFR 3010.120(a),³ all material filed with the

title 39 of the Code of Federal Regulations. Docket No. RM2019–13, Order Reorganizing Commission Regulations and Amending Rules of Practice, January 16, 2020 (Order No. 5407). As a result of Order No. 5407, part 3017 was redesignated as part 3025 and the rules were renumbered on April 20, 2020. *Id.*; Order No. 5439 at 4–5.

³ The Commission’s Filing Online system allows account holders to file materials that contain non-public information. See Postal Regulatory Commission eDockets User Guide, at 40, available at <https://www.prc.gov/sites/default/files/PRCeFilingUserGuideG3032025.pdf>. The filer must adhere to the requirements of 39 CFR 3011 subpart B, including the requirement to concomitantly provide an application for non-public treatment, a redacted (public) version of the non-public

Commission shall be submitted in electronic format using the Filing Online system, which is available over the internet through the Commission's website. The Commission's website accepts filings during the Commission's regular business hours, which are from 8:00 a.m. through 4:30 p.m. Eastern Time, except for Saturdays, Sundays, and Federal holidays. A guide to using the Filing Online system, including how to create an account, is available at <https://www.prc.gov/sites/default/files/PRCeFilingUserGuideG3032025.pdf>. If you have questions about how to use the Filing Online system, please contact the dockets clerk by email at dockets@prc.gov or telephone at (202) 789-6800, option 2. Please be advised that the dockets clerk can only answer procedural questions but may not provide legal advice or recommendations.

Public Representative. Pursuant to 39 CFR 3010.101(q)(3), Matthew Ocksrider is appointed to serve as an officer of the Commission (Public Representative) to represent the interests of the general public in this proceeding.

Availability of documents. Pursuant to rule 3025.103(b), the Commission will post relevant proposals and other materials related to the development of Commission views in this docket.

Federal Register publication. Rule 3025.103(d) requires publication in the **Federal Register** of the notice establishing a docket authorized under part 3025. 39 CFR 3025.103(d). Pursuant to this rule, the Commission directs the Secretary of the Commission to arrange for prompt publication of this Order in the **Federal Register**.

III. Ordering Paragraphs

It is ordered:

1. The Commission establishes Docket No. IM2025-1 for purposes related to the development of section 407(c)(1) views and invites public comments related to this effort, as described in the body of this Order.

2. Comments are due June 6, 2025.

3. Pursuant to 39 CFR 3010.101(q)(3), Matthew Ocksrider is appointed to serve as an officer of the Commission (Public Representative) to represent the interests of the general public in this docket.

4. The Secretary is directed to post documents in this docket when the Commission determines such documents are relevant.

5. The Secretary shall arrange for publication of this Order in the **Federal Register**.

materials, and an unredacted (sealed) version of the non-public materials. See 39 CFR 3011.200(a).

By the Commission.

Jennie L. Jbara,

Primary Certifying Official.

[FR Doc. 2025-06119 Filed 4-9-25; 8:45 am]

BILLING CODE 7710-FW-P

POSTAL REGULATORY COMMISSION

[Docket Nos. MC2025-1287 and K2025-1286; MC2025-1288 and K2025-1287; MC2025-1289 and K2025-1288; MC2025-1290 and K2025-1289; MC2025-1291 and K2025-1290; MC2025-1292 and K2025-1291; MC2025-1293 and K2025-1292; MC2025-1294 and K2025-1293]

New Postal Products

AGENCY: Postal Regulatory Commission.

ACTION: Notice.

SUMMARY: The Commission is noticing a recent Postal Service filing for the Commission's consideration concerning a negotiated service agreement. This notice informs the public of the filing, invites public comment, and takes other administrative steps.

DATES: *Comments are due:* April 14, 2025.

ADDRESSES: Submit comments electronically via the Commission's Filing Online system at <https://www.prc.gov>. Those who cannot submit comments electronically should contact the person identified in the **FOR FURTHER INFORMATION CONTACT** section by telephone for advice on filing alternatives.

FOR FURTHER INFORMATION CONTACT: David A. Trissell, General Counsel, at 202-789-6820.

SUPPLEMENTARY INFORMATION:

Table of Contents

- I. Introduction
- II. Public Proceeding(s)
- III. Summary Proceeding(s)

I. Introduction

Pursuant to 39 CFR 3041.405, the Commission gives notice that the Postal Service filed request(s) for the Commission to consider matters related to Competitive negotiated service agreement(s). The request(s) may propose the addition of a negotiated service agreement from the Competitive product list or the modification of an existing product currently appearing on the Competitive product list.

The public portions of the Postal Service's request(s) can be accessed via the Commission's website (<http://www.prc.gov>). Non-public portions of the Postal Service's request(s), if any, can be accessed through compliance

with the requirements of 39 CFR 3011.301.¹

Section II identifies the docket number(s) associated with each Postal Service request, if any, that will be reviewed in a public proceeding as defined by 39 CFR 3010.101(p), the title of each such request, the request's acceptance date, and the authority cited by the Postal Service for each request. For each such request, the Commission appoints an officer of the Commission to represent the interests of the general public in the proceeding, pursuant to 39 U.S.C. 505 and 39 CFR 3000.114 (Public Representative). Section II also establishes comment deadline(s) pertaining to each such request.

The Commission invites comments on whether the Postal Service's request(s) identified in Section II, if any, are consistent with the policies of title 39. Applicable statutory and regulatory requirements include 39 U.S.C. 3632, 39 U.S.C. 3633, 39 U.S.C. 3642, 39 CFR part 3035, and 39 CFR part 3041. Comment deadline(s) for each such request, if any, appear in Section II.

Section III identifies the docket number(s) associated with each Postal Service request, if any, to add a standardized distinct product to the Competitive product list or to amend a standardized distinct product, the title of each such request, the request's acceptance date, and the authority cited by the Postal Service for each request. Standardized distinct products are negotiated service agreements that are variations of one or more Competitive products, and for which financial models, minimum rates, and classification criteria have undergone advance Commission review. See 39 CFR 3041.110(n); 39 CFR 3041.205(a). Such requests are reviewed in summary proceedings pursuant to 39 CFR 3041.325(c)(2) and 39 CFR 3041.505(f)(1). Pursuant to 39 CFR 3041.405(c)-(d), the Commission does not appoint a Public Representative or request public comment in proceedings to review such requests.

II. Public Proceeding(s)

1. *Docket No(s):* MC2025-1287 and K2025-1286; *Filing Title:* USPS Request to Add Priority Mail & USPS Ground Advantage Contract 686 to the Competitive Product List and Notice of Filing Materials Under Seal; *Filing Acceptance Date:* April 4, 2025; *Filing Authority:* 39 U.S.C. 3642, 39 CFR 3035.105, and 39 CFR 3041.310; *Public*

¹ See Docket No. RM2018-3, Order Adopting Final Rules Relating to Non-Public Information, June 27, 2018, Attachment A at 19-22 (Order No. 4679).

Representative: Kenneth Moeller;
Comments Due: April 14, 2025.

2. *Docket No(s).*: MC2025–1288 and K2025–1287; *Filing Title:* USPS Request to Add Priority Mail & USPS Ground Advantage Contract 687 to the Competitive Product List and Notice of Filing Materials Under Seal; *Filing Acceptance Date:* April 4, 2025; *Filing Authority:* 39 U.S.C. 3642, 39 CFR 3035.105, and 39 CFR 3041.310; *Public Representative:* Almaroof Agoro; *Comments Due:* April 14, 2025.

3. *Docket No(s).*: MC2025–1289 and K2025–1288; *Filing Title:* USPS Request to Add Priority Mail & USPS Ground Advantage Contract 688 to the Competitive Product List and Notice of Filing Materials Under Seal; *Filing Acceptance Date:* April 4, 2025; *Filing Authority:* 39 U.S.C. 3642, 39 CFR 3035.105, and 39 CFR 3041.310; *Public Representative:* Almaroof Agoro; *Comments Due:* April 14, 2025.

4. *Docket No(s).*: MC2025–1290 and K2025–1289; *Filing Title:* USPS Request to Add Priority Mail & USPS Ground Advantage Contract 689 to the Competitive Product List and Notice of Filing Materials Under Seal; *Filing Acceptance Date:* April 4, 2025; *Filing Authority:* 39 U.S.C. 3642, 39 CFR 3035.105, and 39 CFR 3041.310; *Public Representative:* Kenneth Moeller; *Comments Due:* April 14, 2025.

5. *Docket No(s).*: MC2025–1291 and K2025–1290; *Filing Title:* USPS Request to Add Priority Mail & USPS Ground Advantage Contract 690 to the Competitive Product List and Notice of Filing Materials Under Seal; *Filing Acceptance Date:* April 4, 2025; *Filing Authority:* 39 U.S.C. 3642, 39 CFR 3035.105, and 39 CFR 3041.310; *Public Representative:* Christopher Mohr; *Comments Due:* April 14, 2025.

6. *Docket No(s).*: MC2025–1292 and K2025–1291; *Filing Title:* USPS Request to Add Priority Mail & USPS Ground Advantage Contract 691 to the Competitive Product List and Notice of Filing Materials Under Seal; *Filing Acceptance Date:* April 4, 2025; *Filing Authority:* 39 U.S.C. 3642, 39 CFR 3035.105, and 39 CFR 3041.310; *Public Representative:* Christopher Mohr; *Comments Due:* April 14, 2025.

7. *Docket No(s).*: MC2025–1293 and K2025–1292; *Filing Title:* USPS Request to Add Priority Mail & USPS Ground Advantage Contract 692 to the Competitive Product List and Notice of Filing Materials Under Seal; *Filing Acceptance Date:* April 4, 2025; *Filing Authority:* 39 U.S.C. 3642, 39 CFR 3035.105, and 39 CFR 3041.310; *Public Representative:* Jennaca Upperman; *Comments Due:* April 14, 2025.

8. *Docket No(s).*: MC2025–1294 and K2025–1293; *Filing Title:* USPS Request to Add Priority Mail & USPS Ground Advantage Contract 693 to the Competitive Product List and Notice of Filing Materials Under Seal; *Filing Acceptance Date:* April 4, 2025; *Filing Authority:* 39 U.S.C. 3642, 39 CFR 3035.105, and 39 CFR 3041.310; *Public Representative:* Jennaca Upperman; *Comments Due:* April 14, 2025.

III. Summary Proceeding(s)

None. See Section II for public proceedings.

This Notice will be published in the **Federal Register**.

Erica A. Barker,
Secretary.

[FR Doc. 2025–06129 Filed 4–9–25; 8:45 am]

BILLING CODE 7710–FW–P

POSTAL SERVICE

Privacy Act of 1974; System of Records

AGENCY: Postal Service®.

ACTION: Notice of a modified system of records.

SUMMARY: The United States Postal Service® (USPS®) is proposing to revise one Customer Privacy Act Systems of Records (SOR). These updates are being made to implement an application to analyze and anticipate customer needs and assist sales staff.

DATES: These revisions will become effective without further notice on May 12, 2025, unless comments received on or before that date result in a contrary determination.

ADDRESSES: Comments may be submitted via email to the Privacy and Records Management Office, United States Postal Service Headquarters (uspsprivacyfedregnotice@usps.gov). Arrangements to view copies of any written comments received, to facilitate public inspection, will be made upon request.

FOR FURTHER INFORMATION CONTACT: Janine Castorina, Chief Privacy and Records Management Officer, Privacy and Records Management Office, uspsprivacyfedregnotice@usps.gov and by phone at 202–268–2000.

SUPPLEMENTARY INFORMATION:

I. Background

USPS seeks to implement an application to analyze customer interactions with campaign materials, to anticipate customer needs, and to analyze the effectiveness of USPS campaigns.

II. Rationale for Changes to USPS Privacy Act Systems of Records

In its efforts to serve the American people, USPS remains committed to understanding the needs of its customers and improving their experience. To demonstrate the value of products and services to USPS' customers, sales and marketing campaigns are often created to demonstrate the value that the Postal Service can offer. To understand which methods are working well and which can use improvement, USPS seeks to implement an application that allows for analysis of customers' direct engagement with campaign materials. This product will help USPS employees to identify possible trouble areas for customers and offer solutions to fit their needs.

To implement this application, USPS 890.000, Sales, Marketing, Events, and Publications will be modified as follows:

- Two new purposes, twelve and thirteen.
- One new category of records, Customer sharing and analytics data.

III. Description of the Modified System of Records

Pursuant to 5 U.S.C. 552a(e)(11), interested persons are invited to submit written data, views, or arguments on this proposal. A report of the proposed revisions has been sent to Congress and to the Office of Management and Budget for their evaluations. The Postal Service does not expect these amended systems of records to have any adverse effect on individual privacy rights. The notice for modifications to USPS 890.000, Sales, Marketing, Events, and Publications is provided below in its entirety:

SYSTEM NAME AND NUMBER:

USPS 890.000, Sales, Marketing, Events, and Publications.

SECURITY CLASSIFICATION:

None.

SYSTEM LOCATION:

USPS Headquarters Marketing and Public Policy; Integrated Business Solutions Services Centers; National Customer Service Center; Area and District USPS facilities; Post Offices; and contractor sites.

SYSTEM MANAGER(S):

Chief Customer and Marketing Officer and Executive Vice President, United States Postal Service, 475 L'Enfant Plaza SW, Washington, DC 20260–4016.

AUTHORITY FOR MAINTENANCE OF THE SYSTEM:

39 U.S.C. 401, 403, and 404.

PURPOSE(S) OF THE SYSTEM:

1. To understand the needs of customers and improve USPS sales and marketing efforts.
2. To provide appropriate materials and publications to customers.
3. To conduct registration for USPS and related events.
4. To enable access to the USPS meeting and video web conferencing application.
5. To enhance your online meeting experience by utilizing enhanced features and functionality, including voluntary polling to gather responses from attendees to generate reports or the interactive chat feature.
6. To facilitate team collaboration and communication through information sharing and cross-functional participation.
7. To provide users outside of the USPS limited collaboration and communication capabilities through guest account access.
8. To facilitate and support cybersecurity investigations of detected or reported information security incidents.
9. To share your personal image via your device camera during meetings and web conferences, if you voluntarily choose to turn the camera on, enabling virtual face-to-face conversations.
10. To provide pre-registration for guest access to online meetings and web conferences.
11. To facilitate and support marketing initiatives, advertising campaigns, brand strategy, customer experience with products and service, including call centers, strategic customer programs, and innovation and product improvement development.
12. To anticipate customer needs and provide appropriate recommendations.
13. To analyze sales and marketing campaign materials for effectiveness and engagement.

CATEGORIES OF INDIVIDUALS COVERED BY THE SYSTEM:

1. Customers who interact with USPS sales personnel, respond to direct marketing messages, request publications, respond to contests and surveys, voluntarily participate in focus groups, interviews, diaries, observational studies, prototype assessments, A/B comparison tests, and attend USPS events.
2. Customers and other individuals who participate in web-based meeting, video conference, collaboration, and communication applications sponsored by the USPS.

CATEGORIES OF RECORDS IN THE SYSTEM:

1. *Customer information:* Customer and key contacts' names, date of birth,

age, home mailing address, and email address; phone, fax, and pager numbers; company name, job descriptions, titles, roles, level, and company address; other names and emails provided by customers.

2. *Identifying information:* Customer ID(s), D-U-N-S Numbers, USPS account numbers, meter numbers, and signatures.

3. *Business specific information:* Firm name, size, and years in business; number of employees; sales and revenue information; business sites and locations; URLs; company age; industrial classification numbers; use of USPS and competitor's products and services; types of customers served; customer equipment and services; advertising agency and spending; names of USPS employees serving the firm; and calls made.

4. *Information specific to companies that act as suppliers to USPS:* Contract start and end dates, contract award number, contract value, products and/or services sold under contract.

5. Information provided by customers as part of a survey or contest.

6. *Payment information:* Credit and/or debit card number, type, expiration date, and check information; and ACH information.

7. *Event information:* Name of event; role at event; itinerary; and membership in a PCC.

8. *Customer preferences:* Preferences for badge name and accommodations.

9. *Survey data:* customer perception, feelings, habits, past behaviors, preferences, recommended improvements, willingness to buy, ownership, and hypothetical future scenarios.

10. *Participant session data from web-based meetings and web conferences:* Participant name, participant's webcam-generated image (including presenters), recorded participant audio, video, and shared meeting screen content, chat interaction, polling questions and associated responses, participant join time and leave time, meeting duration, participant location, and participant media hardware information, Participant Job Information, Participant Stated Locale, Participant Connection Type, Participant Data Center, Participant Device Type, Participant Domain, Participant Full Data Center, Participant Hard Disk ID, Participant ID, Participant IP Address, Participant Join Time, Participant Camera Name, Participant MAC Address, Participant Microphone Name, Participant Network Type, Participant PC Name, Participant Role, Participant Share Settings, Participant Speaker Name, Participant Status, Participant User ID, Participant

User Name, Participant Zoom, Participant SIP URL, Participant Leave Reason, Participant AS Input, Participant AS Output, Participant Audio Input, Participant Audio Output, Participant CPU Usage, Participant Video Input, Participant Video Output, Participant Quality, Participant Sharing Details, Participant Recording Details.

11. *Device data from web-based meetings and web conferences:* Device type (such as mobile, desktop, or tablet), Device Operating System, Number of users of related Operating Systems, Operating System Version, Operating System Type, MAC address, and IP address, hard disk ID, PC Name, Bluetooth Information, Packet Loss, internet Connection Type, Bluetooth Device Name, Bluetooth Device Type, Device Architecture, Central Processing Unit (CPU) Core Type, CPU core frequency, CPU Brand, Available Memory, Total CPU Capacity, Total Capacity Utilized by Application, Memory Used by Application, API Permissions, API Authentication, Authentication Secret Key, Graphics Processing Unit (GPU) Brand, GPU Type, Custom Attributes Defined by Organization, Archived Meeting Files, Archive Meeting Account Name, Archived Meeting File Download User, Archived Meeting File Extension, Archived Meeting File Size, Archived Meeting File Type, Archived Meeting File ID, Archived Meeting File Participant Email, Archived Meeting Participant Join Time, Archived Meeting Participant Leave Time, Archived Meeting File Recording Type, Archived Meeting File Status, Archived Meeting Complete Time, Archived Meeting Complete Time Duration, Archived Meeting Duration, Archived Meeting Duration In Seconds, Archived Meeting Host ID, Archived Meeting ID, Archived Meeting Settings, Archived Meeting Type, Archived Meeting Recording Count, Archived Meeting Start Time, Archived Meeting Topic, Archived Meeting Total Size, Archived Meeting UU ID, Past Meeting Participant ID, Past Meeting Participant Name, Past Meeting Participant Email, SIP Phone Authorization Name, SIP Phone Domain, SIP Phone ID, SIP Phone Password, SIP Phone Proxy Servers, SIP Phone Register Servers, SIP Phone Registration Expire Time, SIP Phone Transport Protocols, SIP Phone User Email, SIP Phone User Name, SIP Phone Voice Voicemail.

12. *User data from web-based meetings and web conferences:* User Creation Date, User Department, User Email Address, User Employee ID, User Name, User System ID, User Chat Group Ids, User System Client Version, User

Last Login Time, User Picture URL, User PMI, User Status, User Timezone, User Type, User Verified Status, User Password, User JID, User Language, User Manager, User Personal Meeting URL, User Role ID, User Role Name, User Use PMI Status, User Phone Country, User Company, User Custom Attributes, User CMS User ID, User Pronouns, User Vanity Name, User Assistant Email, User Assistant ID, User Permissions, User Presence Status, User Scheduler Email, User Scheduler ID, User Settings, User Token, User Meeting Minutes, User Number Of Meetings, User Participant Number, User's Web Conferences Template, User Scheduled Web Conferences, User Web Conferences Settings, User Web Conferences Recurrence Settings, User Web Conferences Password, User Web Conferences Agenda, User Web Conferences Duration, User Web Conferences Start Time, User Web Conferences Template ID, User Web Conferences Topic, User Web Conferences Tracking Fields, User Web Conferences Time zone, User Web Conferences Created Date, User Web Conferences Host ID, User Web Conferences Type, User Web Conferences UU ID, User Web Conferences Start URL, User TSP Account Conference Code, User TSP Account Dial-In Numbers, User TSP Account ID, User TSP Account Leader PIN, User TSP account TSP Bridge, User TSP Audio URL, Chat Messaging Content.

13. *Web-based meeting and web conference administration data:* Account Administrator Name, Account Contact Information Account ID, Account Billing Information, Account Plan Information, Conference Room Account type, Conference Room calendar name, conference room camera name, conference room device IP address, conference room email address, conference room health, conference room ID, conference room issues, conference room last start time, conference room microphone name, conference room name, conference room speaker name, conference room status, Conference Room live meeting, Conference Room past meetings, conference room activation code, conference room support email, conference room support phone, conference room passcode, conference room settings, conference room location description, conference room location name, User Sign In And Sign Out Times, Deleted Message Sender, Deleted Message Time, Deleted Message ID, Deleted Message Text, Deleted Message Main Message ID, Deleted Message Main

Message Timestamp, Deleted Message File Name, Deleted Message File Size, Edited Message Sender, Edited Message Time, Edited Message ID, Edited Message Text, Edited Message Main Message ID, Edited Message Main Message Timestamp, Edited Message File Name, Edited Message File Size, Message Sender, Message Time, Message ID, Message Main Message ID, Message Main Message Timestamp, Message File, Message File Size, Group admin name, Group admin email, group admin ID, group member email, group member first name, group member last name, group member ID, group member type, chat group ID, chat group name, chat group total members, chat group, Files sent through chat, GIPHY's sent through chat, groups sent through chat, p2p sent through chat, text sent through chat, total sent through chat, audio sent through chat, code snippet sent through chat, Operation Log action, operation log category type, operation log operation detail, operation log user, operation log time, Role member department, role member email, role member first name, role member ID, role member type, client feedback detail email, client feedback detail meeting ID, client feedback detail participant name, client feedback detail time.

14. *Web-Based Meeting And Web Conference Telemetry Data:* Event Time, Client Type, Event Location, Event, Subevent, UUID, Client Version, UserID, Client OS, Meeting ID.

15. *Chat Application Telemetry Data:* User Email, Group Chat, Message Type, In Meeting Message, Status, Do Not Disturb Time, Notification Setting, Show Group On Contact List, File Type, File Location, Link URL, Keywords, GIF Keywords, Emoji Code, Audio Setting, Video Setting, Is E2E Enabled, Message ID, IP Address.

16. *Communication Data:* Deleted Persistent Message Sender, Deleted Persistent Message Time, Deleted Persistent Message ID, Deleted Persistent Message Text, Deleted Persistent Message Main Message ID, Deleted Persistent Message Main Message Timestamp, Deleted Persistent Message File Name, Deleted Persistent Message File Size, Edited Persistent Message Sender, Edited Persistent Message Time, Edited Persistent Message ID, Edited Persistent Message Text, Edited Persistent Message Main Message ID, Edited Persistent Message Main Message Timestamp, Edited Persistent Message File Name, Edited Persistent Message File Size, Persistent Message Sender, Persistent Message Time, Persistent Message ID, Persistent Message Main Message ID, Persistent Message Main Message Timestamp,

Persistent Message File, Persistent Message File Size, Persistent Message Images Exchanged, Persistent Message Files Exchanged, Persistent Message Videos Exchanged, Persistent Message Channel Title, Persistent Message Whiteboard Annotations, Persistent Message Text, Deleted Message Sender, Deleted Message Time, Deleted Message ID, Deleted Message Text, Deleted Message Main Message ID, Deleted Message Main Message Timestamp, Deleted Message File Name, Deleted Message File Size, Edited Message Sender, Edited Message Time, Edited Message ID, Edited Message Text, Edited Message Main Message ID, Edited Message Main Message Timestamp, Edited Message File Name, Edited Message File Size, Message Sender, Message Time, Message ID, Message Main Message ID, Message Main Message Timestamp, Message File, Message File Size, Message Text.

17. *Survey data:* customer perception, feelings, habits, past behaviors, preferences, recommended improvements, willingness to buy, ownership, and hypothetical future scenarios.

18. *Customer sharing and analytics data:* Analytics program shared by email address, analytics program shared to email address, Analytics program shared by name, Analytics program report data, Analytics shared document viewed count, Analytics shared document viewer email address, Analytics shared document viewer name, Analytics shared document reports, custom web page view count, custom web page shared by email address, custom web page shared to email address, custom web page shared by name, custom web page shared to name, custom web page share number, custom web page share views, custom web page user insights, customer sharing program usage report data, customer meeting insights.

RECORD SOURCE CATEGORIES:

Customers, USPS personnel, and list providers.

ROUTINE USES OF RECORDS MAINTAINED IN THE SYSTEM, INCLUDING CATEGORIES OF USERS AND THE PURPOSES OF SUCH USES:

Standard routine uses 1. through 7., 10., and 11. apply.

POLICIES AND PRACTICES FOR STORAGE OF RECORDS:

Automated databases, computer storage media, and paper.

POLICIES OF PRACTICES FOR RETRIEVAL OF RECORDS:

1. For sales, events, and publications, information is retrieved by customer

name or customer ID(s), mail or email address, and phone number.

2. For direct marketing, information is retrieved by Standard Industry Code (SIC) or North American Industry Classification System (NAISC) number, and company name.

3. Report and tracking data created during web-based meetings and video conferences that pertain to individual participants, content shared, conference codes and other relevant session data and historical device usage data, are retrieved by meeting ID, host name or host email address.

4. Records pertaining to web-based collaboration and communication applications are retrieved by organizer name and other associated personal identifiers.

5. Media recordings created during web-based meetings and video conferences are retrieved by meeting ID, host name or host email address.

6. Web-based meeting and video session recordings are retrieved by meeting ID, host name or host email address.

7. Customer Insight materials are retrieved by name and email address.

POLICIES AND PRACTICES FOR RETENTION AND DISPOSAL OF RECORDS:

1. Records relating to organizations and publication mailing lists are retained until the customer ceases to participate.

2. ACH records are retained up to 2 years. Records relating to direct marketing, advertising, and promotions are retained 5 years.

3. Other records are retained 3 years after the relationship ends.

4. Report and tracking data created during web-based meeting and video conferences, such as session data and historical device usage data, are retained for twenty-four months.

5. Records pertaining to web-based collaboration and communication applications are retained for twenty-four months.

6. Web-based meeting and video session recordings are retained for twenty-four months.

7. Customer insight, market research, and survey records will be retained for 3 years.

Records existing on paper are destroyed by burning, pulping, or shredding. Records existing on computer storage media are destroyed according to the applicable USPS media sanitization practice.

ADMINISTRATIVE, TECHNICAL, AND PHYSICAL SAFEGUARDS:

Paper records, computers, and computer storage media are located in controlled-access areas under supervision of program personnel. Access to these areas is limited to authorized personnel, who must be identified with a badge.

Access to records is limited to individuals whose official duties require such access. Contractors and licensees are subject to contract controls and unannounced on-site audits and inspections.

Computers are protected by mechanical locks, card key systems, or other physical access control methods. The use of computer systems is regulated with installed security software, computer logon identifications, and operating system controls including access controls, terminal and transaction logging, and file management software. Online data transmission is protected by encryption.

RECORD ACCESS PROCEDURES:

Requests for access must be made in accordance with the Notification Procedure above and USPS Privacy Act regulations regarding access to records and verification of identity under 39 CFR 266.5.

CONTESTING RECORD PROCEDURES:

See Notification Procedure and Record Access Procedures above.

NOTIFICATION PROCEDURES:

For information pertaining to sales, inquiries should be addressed to: Sales and Customer Relations 475 L'Enfant Plaza SW, Washington, DC 20260.

Customers wanting to know if other information about them is maintained in this system of records must address inquiries in writing to the Chief Customer and Marketing Officer and Executive Vice President and include their name and address.

EXEMPTIONS PROMULGATED FOR THE SYSTEM:

None.

HISTORY:

August 4, 2020, 85 FR 47258; June 1, 2020, 85 FR 33208; October 24, 2011, 76 FR 65756; April 29, 2005, 70 FR 22516.

Kevin Rayburn,

Attorney, Ethics and Legal Compliance.

[FR Doc. 2025-06117 Filed 4-9-25; 8:45 am]

BILLING CODE 7710-12-P

RAILROAD RETIREMENT BOARD

Proposed Collection; Comment Request

Summary: In accordance with the requirement of section 3506(c)(2)(A) of the Paperwork Reduction Act of 1995 which provides opportunity for public comment on new or revised data collections, the Railroad Retirement Board (RRB) will publish periodic summaries of proposed data collections.

Comments are invited on: (a) Whether the proposed information collection is necessary for the proper performance of the functions of the agency, including whether the information has practical utility; (b) the accuracy of the RRB's estimate of the burden of the collection of the information; (c) ways to enhance the quality, utility, and clarity of the information to be collected; and (d) ways to minimize the burden related to the collection of information on respondents, including the use of automated collection techniques or other forms of information technology.

1. *Title and purpose of information collection:* Application for Benefits Due But Unpaid at Death; OMB 3220-0055.

Under Section 2(g) of the Railroad Unemployment Insurance Act (45 U.S.C. 352), benefits that accrued but were not paid because of the death of the employee shall be paid to the same individual(s) to whom benefits are payable under section 6(a)(1) of the Railroad Retirement Act. The provisions relating to the payment of such benefits are prescribed in 20 CFR 325.5 and 20 CFR 335.5.

The RRB provides Form UI-63, Application for Benefits Due But Unpaid at Death, to those applying for the accrued sickness or unemployment benefits unpaid at the death of the employee and for obtaining the information needed to identify the proper payee. One response is requested of each respondent. Completion is required to obtain a benefit. The RRB proposes the following changes to Form UI-63:

- On the cover letter, removed "his or her" and replaced with "their" in second sentence and
- On the second page, field 4, added "Telephone No." column.

ESTIMATE OF ANNUAL RESPONDENT BURDEN

Form No.	Annual responses	Time (minutes)	Burden (hours)
UI-63	30	7	4

2. Title and purpose of information collection: Employee's Certification; OMB 3220-0140.

Section 2 of the Railroad Retirement Act (RRA) (45 U.S.C. 231a), provides for the payment of an annuity to the spouse or divorced spouse of a retired railroad employee. For the spouse or divorced spouse to qualify for an annuity, the RRB must determine if any of the employee's current marriage to the applicant is valid.

The requirements for obtaining documentary evidence to determine valid marital relationships are prescribed in 20 CFR 219.30 through 219.35. Section 2(e) of the RRA requires that an employee must relinquish all

rights to any railroad employer service before a spouse annuity can be paid.

The RRB uses Form G-346, Employee's Certification, to obtain the information needed to determine whether the employee's current marriage is valid. Form G-346 is completed by the retired employee who is the husband or wife of the applicant for a spouse annuity. Completion is required to obtain a benefit. One response is requested of each respondent. *The RRB proposes minor changes to Form G-346 certification statement on page 2 and Paperwork Reduction Act Notice contact information on page 3.*

Consistent with 20 CFR 217.17, the RRB uses Form G-346sum, *Employee's*

Certification Summary, which mirrors the information collected on Form G-346, when an employee, after being interviewed by an RRB field office representative "signs" the form using an alternative signature method known as "attestation." Attestation refers to the action taken by the RRB field office representative to confirm and annotate the RRB's records of the applicant's affirmation under penalty of perjury that the information provided is correct and the applicant's agreement to sign the form by proxy. Completion is required to obtain a benefit. One response is requested of each respondent. The RRB proposes no changes to Form G-346sum.

ESTIMATE OF ANNUAL RESPONDENT BURDEN

Form No.	Annual responses	Time (minutes)	Burden (hours)
G-346	2,060	5	172
G-346sum	1,960	5	163
Total	4,020	335

3. Title and purpose of information collection: RUIA Claims Notification and Verification System; OMB 3220-0171.

Section 5(b) of the Railroad Unemployment Insurance Act (RUIA) (45 U.S.C. 355), requires that effective January 1, 1990, when a claim for benefits is filed with the Railroad Retirement Board (RRB), the RRB shall provide notice of the claim to the claimant's base year employer(s) to provide them an opportunity to submit information relevant to the claim before making an initial determination. If the RRB determines to pay benefits to the claimant under the RUIA, the RRB shall notify the base-year employer(s).

The purpose of the RUIA Claims Notification and Verification System is to provide two notices, pre-payment Form ID-4K, Prepayment Notice of Employees' Applications and Claims for

Benefits Under the Railroad Unemployment Insurance Act, and post-payment Form ID-4E, Notice of RUIA Claim Determination. Prepayment Form ID-4K provides notice to a claimant's base-year employer(s), of each unemployment application and unemployment and sickness claim filed for benefits under the RUIA and provides the employer an opportunity to convey information relevant to the proper adjudication of the claim.

The railroad employer can elect to receive Form ID-4K by one of three options: a computer-generated paper notice, by Electronic Data Interchange (EDI), or online via the RRB's Employer Reporting System (ERS). The railroad employer can respond to the ID-4K notice by telephone, manually by mailing a completed ID-4K back to the RRB, or electronically via EDI or ERS. Completion is voluntary.

Once the RRB determines to pay a claim post-payment Form Letter ID-4E, Notice of RUIA Claim Determination, is used to notify the base-year employer(s). This gives the employer a second opportunity to challenge the claim for benefits.

The ID-4E mainframe-generated paper notice, EDI, and internet versions are transmitted on a daily basis, generally on the same day that the claims are approved for payment. Railroad employers who are mailed Form ID-4E are instructed to write if they want a reconsideration of the RRB's determination to pay. Employers who receive the ID-4E electronically, may file a reconsideration request by completing the ID-4E by either EDI or ERS. Completion is voluntary. *The RRB proposes no changes to Forms ID-4K, ID-4K (internet), ID-4E, and ID-4E (internet).*

ESTIMATE OF ANNUAL RESPONDENT BURDEN

Form No.	Annual responses	Time (minutes)	Burden (hours)
ID-4K (Manual)	1,250	2	42
ID-4K (FTP)	15,600	(*)	210

ESTIMATE OF ANNUAL RESPONDENT BURDEN—Continued

Form No.	Annual responses	Time (minutes)	Burden (hours)
ID-4K (Internet)	63,000	2	2,100
ID-4E (Manual)	50	2	2
ID-4E (Internet)	120	2	4
Total	80,020	2,358

* The burden for the railroad employers receiving file transfer protocol (FTP) messages has been calculated in the following manner. We estimate that 10 minutes a day would be required on average for each of the 5 railroad employers to operate the system. Based on 251 workdays in a year, we calculate the number of burden hours to be 210 hours, of which we allocated 40 percent to unemployment transactions (84 burden hours) and 60 percent to sickness transactions (126 burden hours).

Additional Information or Comments:
To request more information or to obtain a copy of the information collection justification, forms, and/or supporting material or comments regarding the information collection should be addressed to Brian Foster, Railroad Retirement Board, 844 North Rush Street, Chicago, Illinois 60611-1275 or emailed to Brian.Foster@rrb.gov. Written comments should be received within 60 days of this notice.

Brian D. Foster,
Clearance Officer.

[FR Doc. 2025-06113 Filed 4-9-25; 8:45 am]

BILLING CODE 7905-01-P

SECURITIES AND EXCHANGE COMMISSION

[Release No. 34-102773; File No. 10-249]

Texas Stock Exchange LLC; Notice of Filing of Application, as Amended, for Registration as a National Securities Exchange Under Section 6 of the Securities Exchange Act of 1934

April 4, 2025.

On January 31, 2025, Texas Stock Exchange LLC (“TXSE”) filed with the Securities and Exchange Commission (“Commission”) a Form 1 application under the Securities Exchange Act of 1934 (“Exchange Act”), seeking registration as a national securities exchange under Section 6 of the Exchange Act. On April 2, 2025, TXSE submitted Amendment No. 1 to its Form 1 application.¹ TXSE’s Form 1 application, as amended, provides detailed information on how it proposes

¹ In Amendment No. 1, TXSE submitted updated portions of its Form 1 application, including Exhibits A-3 (Proposed First Amended and Restated Limited Liability Company Agreement of Texas Stock Exchange LLC), B-1 (Rules of TXSE), C (information regarding subsidiaries or affiliates), E (description of the proposed operation of the exchange), H (listing applications), J (list of officers, governors, members of all standing committees, or persons performing similar functions), and K (Shareholders owning 5% or more).

to satisfy the requirements of the Exchange Act.

The Commission is publishing this notice to solicit comments on TXSE’s Form 1 application. The Commission will take any comments it receives into consideration in making its determination about whether to grant TXSE’s request to register as a national securities exchange. The Commission will grant the registration if it finds that the requirements of the Exchange Act and the rules and regulations thereunder with respect to TXSE are satisfied.²

With respect to governance, TXSE would be a subsidiary of its parent company, TXSE Group Inc. (“TXSE Group”), which would directly hold 100% of the equity of TXSE. In turn, TXSE Group would be owned by a group of investors that are party to a stockholders’ agreement (“Stockholders’ Agreement”). The Stockholders’ Agreement would provide a 40% cap on beneficial ownership of stock of TXSE Group by any person (alone or together with its related persons) and would further cap beneficial ownership of TXSE Group by members of TXSE at 20%.³ The governing documents for TXSE can be found in Exhibit A to TXSE’s Form 1 application, and a listing of the officers and directors of TXSE can be found in Exhibit J. The governing documents for TXSE Group, including the Stockholders’ Agreement, can be found in Exhibit C to TXSE’s Form 1 application.

With respect to its trading system, the Form 1 application provides that TXSE would operate a fully automated limit order book for orders to buy and sell securities with a continuous automated matching function. TXSE would execute

² 15 U.S.C. 78s(a).

³ The proposed Fourth Amended and Restated Certificate of Incorporation of TXSE Group Inc. contains similar ownership limitations, and also provides that no member of a national securities exchange controlled by TXSE Group (alone or together with its related person) would be entitled to vote or cause the voting of more than 20% of the outstanding votes entitled to be cast on any matter.

orders in price/time priority, and would “rank equally priced trading interest within the System in time priority in the following order: (i) The portion of a Limit Order with a Displayed instruction; (ii) Limit Orders with a Non-Displayed instruction (including the Reserve Quantity of Limit Orders); and (iii) Orders with a Peg instruction, ranked in priority based upon the time such orders were initially received by the System.”⁴ TXSE would not maintain a physical trading floor. Liquidity would be derived from orders to buy and orders to sell submitted to TXSE electronically by its registered broker-dealer members from remote locations. TXSE would have one class of membership open to registered broker-dealers, and also would allow members to register under TXSE rules as market makers on TXSE and be subject to certain specified requirements and obligations set forth in TXSE’s proposed rules. According to TXSE, it “intends for its System to be relatively simple, without many of the complex order types or instructions available on other national securities exchanges.”⁵

A more detailed description of the manner of operation of TXSE’s proposed system can be found in Exhibit E to TXSE’s Form 1 application. The proposed rulebook for the proposed exchange can be found in Exhibit B to TXSE’s Form 1 application. A complete set of forms concerning membership and access can be found in Exhibit F to TXSE’s Form 1 application.

TXSE’s Form 1 application, including all of the Exhibits referenced above, is available online at www.sec.gov/rules/other.shtml as well as in the Commission’s Public Reference Room. Interested persons are invited to submit written data, views, and arguments concerning TXSE’s Form 1, including whether the application is consistent with the Exchange Act. Comments may

⁴ Proposed TXSE Rule 11.008. Capitalized terms used but not defined herein have the meanings specified in Exhibit B-1.

⁵ Form 1, Exhibit E at 6.

be submitted by any of the following methods:

Electronic Comments

- Use the Commission's internet comment form (<https://www.sec.gov/rules/sro.shtml>); or
- Send an email to rule-comments@sec.gov. Please include file number 10–249 on the subject line.

Paper Comments

- Send paper comments in triplicate to Secretary, Securities and Exchange Commission, 100 F Street NE, Washington, DC 20549–1090.

All submissions should refer to file number 10–249. This file number should be included on the subject line if email is used. To help the Commission process and review your comments more efficiently, please use only one method. The Commission will post all comments on the Commission's internet website (<https://www.sec.gov/rules/other.shtml>). Copies of the submission, all subsequent amendments, all written statements with respect to TXSE's Form 1 filed with the Commission, and all written communications relating to the application between the Commission and any person, other than those that may be withheld from the public in accordance with the provisions of 5 U.S.C. 552, will be available for website viewing and printing in the Commission's Public Reference Room, 100 F Street NE, Washington, DC 20549, on official business days between the hours of 10 a.m. and 3 p.m. Copies of the filing also will be available for inspection and copying at the principal office of the Exchange. Do not include personal identifiable information in submissions; you should submit only information that you wish to make available publicly. We may redact in part or withhold entirely from publication submitted material that is obscene or subject to copyright protection. All submissions should refer to file number 10–249 and should be submitted on or before May 27, 2025.

For the Commission, by the Division of Trading and Markets, pursuant to delegated authority.⁶

Vanessa A. Countryman,
Secretary.

[FR Doc. 2025–06116 Filed 4–9–25; 8:45 am]

BILLING CODE 8011–01–P

SECURITIES AND EXCHANGE COMMISSION

[SEC File No. 270–42, OMB Control No. 3235–0047]

Proposed Collection; Comment Request; Extension: Rule 204–3

Upon Written Request, Copies Available From: Securities and Exchange Commission, Office of FOIA Services, 100 F Street NE, Washington, DC 20549–2736

Notice is hereby given that pursuant to the Paperwork Reduction Act of 1995 (44 U.S.C. 3501 *et seq.*) the Securities and Exchange Commission (“Commission”) is soliciting comments on the collection of information summarized below. The Commission plans to submit this existing collection of information to the Office of Management and Budget for extension and approval.

The title for the collection of information is “Rule 204–3 (17 CFR 275.204–3) under the Investment Advisers Act of 1940.” (15 U.S.C. 80b). Rule 204–3, the “brochure rule,” requires advisers to deliver their brochures and brochure supplements at the start of an advisory relationship and to deliver annually thereafter the full updated brochure or a summary of material changes to their brochure. The rule also requires that advisers deliver an amended brochure or brochure supplement (or just a statement describing the amendment) to clients only when disciplinary information in the brochure or supplement becomes materially inaccurate. The brochure assists the client in determining whether to retain, or continue employing, the adviser. The information that Rule 204–3 requires to be contained in the brochure is also used by the Commission and staff in its enforcement, regulatory, and examination programs. This collection of information is found at 17 CFR 275.204–3 and is mandatory.

The respondents to this information collection are certain investment advisers registered with the Commission. Our latest data indicate that there were 15,464 advisers registered with the Commission as of March 31, 2024. The Commission has estimated that compliance with Rule 204–3 imposes a burden of approximately 4.04 hours annually based on advisers having a median of 95 clients each. Based on this figure, the Commission estimates a total annual burden of 62,525 hours for this collection of information.

Rule 204–3 does not require recordkeeping or record retention. The

collection of information requirements under the rule are mandatory. The information collected pursuant to the rule is not filed with the Commission, but rather takes the form of disclosures to clients and prospective clients. Accordingly, these disclosures are not kept confidential. An agency may not conduct or sponsor, and a person is not required to respond to, a collection of information unless it displays a currently valid control number.

Written comments are invited on: (a) whether the proposed collection of information is necessary for the proper performance of the functions of the Commission, including whether the information shall have practical utility; (b) the accuracy of the Commission's estimate of the burden of the collection of information; (c) ways to enhance the quality, utility, and clarity of the information collected; and (d) ways to minimize the burden of the collection of information on respondents, including through the use of automated collection techniques or other forms of information technology. Consideration will be given to comments and suggestions submitted by June 9, 2025.

Please direct your written comments to: Austin Gerig, Director/Chief Data Officer, Securities and Exchange Commission, c/o Tanya Rutenberg, 100 F Street NE, Washington, DC 20549 or send an email to:

PaperworkReductionAct@sec.gov.

Dated: April 7, 2025.

Sherry R. Haywood,
Assistant Secretary.

[FR Doc. 2025–06122 Filed 4–9–25; 8:45 am]

BILLING CODE 8011–01–P

SECURITIES AND EXCHANGE COMMISSION

[Release No. 34–102772; File No. SR–SAPPHIRE–2025–15]

Self-Regulatory Organizations; MIAX Sapphire, LLC; Notice of Filing and Immediate Effectiveness of Proposed Rule Change To Adopt Exchange Rule 2005, Error Accounts

April 4, 2025.

Pursuant to Section 19(b)(1) of the Securities Exchange Act of 1934 (“Act”),¹ and Rule 19b–4 thereunder,² notice is hereby given that on April 1, 2025, MIAX Sapphire, LLC (“MIAX Sapphire” or “Exchange”) filed with the Securities and Exchange Commission (“Commission”) the proposed rule change as described in Items I and II

¹ 15 U.S.C. 78s(b)(1).

² 17 CFR 240.19b–4.

⁶ 17 CFR 200.30–3(a)(71)(i).

below, which Items have been prepared by the Exchange. The Commission is publishing this notice to solicit comments on the proposed rule change from interested persons.

I. Self-Regulatory Organization's Statement of the Terms of Substance of the Proposed Rule Change

The Exchange proposes to amend Exchange Rule 100 to make a minor non-substantive correction to the rule to improve the clarity of the rule text; and (ii) adopt Exchange Rule 2005 to establish rules related to the use of Floor Broker³ error accounts.

The text of the proposed rule change is available on the Exchange's website at <https://www.miaxglobal.com/markets/us-options/miax-sapphire/rule-filings>, at the Exchange's principal office, and at the Commission's Public Reference Room.

II. Self-Regulatory Organization's Statement of the Purpose of, and Statutory Basis for, the Proposed Rule Change

In its filing with the Commission, the Exchange included statements concerning the purpose of and basis for the proposed rule change and discussed any comments it received on the proposed rule change. The text of these statements may be examined at the places specified in Item IV below. The Exchange has prepared summaries, set forth in sections A, B, and C below, of the most significant aspects of such statements.

A. Self-Regulatory Organization's Statement of the Purpose of, and Statutory Basis for, the Proposed Rule Change

1. Purpose

The Exchange proposes to amend the definition of "Participant" in Exchange Rule 100 to replace the phrase, "that includes a Floor Participant" with the phrase, "and includes a Floor Participant" to provide clarity in the rule text. As amended, the rule will provide that, "[t]he term 'Participant' means a firm, or organization that is

³ A Floor Broker is an individual who is registered with the Exchange for the purpose, while on the Trading Floor, of accepting and handling options orders. See Exchange Rule 2015. The term "Trading Floor" or "Floor" means the physical trading floor of the Exchange located in Miami, Florida. The Trading Floor shall consist of one "Crowd Area" or "Pit" where Floor Participants will be located and option contracts will be traded. The Crowd Area or Pit shall be marked with specific visible boundaries on the Trading Floor, as determined by the Exchange. A Floor Broker must represent all orders in an "open outcry" fashion in the Crowd Area. See Exchange Rule 100.

registered with the Exchange pursuant to Chapter II of [MIAX Sapphire] Rules for purposes of participating in trading on a facility of the Exchange and includes a Floor Participant."

The Exchange also proposes to adopt Exchange Rule 2005 to establish rules related to the use of Floor Broker error accounts. First, the Exchange proposes that each Participant⁴ who conducts a business as a Floor Broker on the Exchange and who is not self-clearing must establish and maintain an account with a Clearing Member⁵ of the Exchange, for the sole purpose of carrying positions resulting from bona fide errors made in the course of its floor brokerage business.⁶ Further, with respect to Floor Brokers only, such an account for option transactions must be maintained with an entity that is also a member of The Options Clearing Corporation.

In practice, a Floor Broker will remedy a bona fide error by entering a subsequent trade on behalf of the customer on the correct terms of the original order.⁷ These types of transactions are transactions which broker-dealers place to remedy the execution of customer orders that have been placed in error or mishandled due to an error involving any term of an order, including but not limited to (for example), price, number of contracts, identification of security, or execution of a transaction on the wrong side of the market.

⁴ The term "Participant" means a firm, or organization that is registered with the Exchange pursuant to Chapter II of MIAX Sapphire Rules for purposes of participating in trading on a facility of the Exchange that includes a Floor Participant. See Exchange Rule 100. (The Exchange notes that it is revising a portion of this definition with this filing.)

⁵ The term "Clearing Member" means a Member that has been admitted to membership in the Clearing Corporation pursuant to the provisions of the Rules of the Clearing Corporation. See Exchange Rule 100.

⁶ A "Bona fide error" is defined as (i) the inaccurate conveyance or execution of any term of an order including, but not limited to, price, number of shares or other unit of trading; identification of the security; identification of the account for which securities are purchased or sold; lost or otherwise misplaced order tickets; short sales that were instead sold long or vice versa; or the execution of an order on the wrong side of a market; (ii) the unauthorized or unintended purchase, sale, or allocation of securities, or the failure to follow specific client instructions; (iii) the incorrect entry of data into relevant systems, including reliance on incorrect cash positions, withdrawals, or securities positions reflected in an account; or (iv) a delay, outage, or failure of a communication system used to transmit market data prices or to facilitate the delivery of an order. See Securities Exchange Act Release No. 55884 (June 8, 2007), 72 FR 32926 (June 14, 2007) (Order Exempting Certain Error Correction Transactions from Rule 611 of Regulation NMS under the Securities Exchange Act of 1934).

⁷ The erroneous trade is moved to the Floor Broker's error account for disposition.

Next, the Exchange proposes that each Participant which conducts business as a Floor Broker must make available to the Exchange, upon request, accurate and complete records of all trades cleared in such Participant's error account. These records must include the following audit trail elements: (1) name or identifying symbol of the security; (2) number of shares or quantity of security; (3) transaction price; (4) time of trade execution; (5) executing Floor Broker badge number, or alpha symbol as may be used from time to time, in regard to its side of the contract; (6) executing Floor Broker badge number, or alpha symbol as may be used from time to time, of the contra side to the contract; (7) clearing firm number, or alpha symbol as may be used from time to time, in regard to its side of the contract; (8) clearing firm number, or alpha symbol as may be used from time to time, in regard to the contra side of the contract; (9) designation of whether the account for which the order was executed was that of a Participant; (10) the nature and amount of the error; (11) the Participant that cleared the error trade on the Participant's behalf; (12) an explanation of the means by which the Participant resolved the error; (13) the aggregate amount of liability that the Participant incurred, and: (i) had outstanding as of the time each such error trade entry was recorded or (ii) had cleared by other Participant. The Exchange believes that it is important for the Participant to provide the above information because it will aid the Exchange in the surveillance of error account activity. The Exchange notes that the proposed rule is substantially similar to rules at other options exchanges with open outcry trading floors.⁸

2. Statutory Basis

The Exchange believes that its proposal is consistent with Section 6(b) of the Act⁹ in general, and furthers the objectives of Section 6(b)(5) of the Act¹⁰ in particular, in that it is designed to prevent fraudulent and manipulative acts and practices, to promote just and equitable principles of trade, to foster cooperation and coordination with persons engaged in facilitating transactions in securities, to remove impediments to and perfect the mechanism of a free and open market and a national market system, and, in general to protect investors and the public interest. Additionally, the

⁸ See BOX Exchange Rule 3030 and NYSE Arca Exchange Rule 11.17.

⁹ 15 U.S.C. 78f(b).

¹⁰ 15 U.S.C. 78f(b)(5).

Exchange believes the proposed rule change is consistent with the Section 6(b)(5)¹¹ requirement that the rules of an exchange not be designed to permit unfair discrimination between customers, issuers, brokers, or dealers, because the rule applies to all Participants equally.

Specifically, the Exchange believes the proposed amendment to the definition of Participant will remove impediments to and perfect the mechanism of a free and open market and a national market system because it would provide clarity in the Exchange's rule text. The proposed change provides additional clarity within the rule text, making the Exchange's rules easier to understand. The proposed rule change would, therefore, help prevent any potential investor confusion and thus protect investors and the public interest. The Exchange also believes that the proposed rule change is non-discriminatory as the rules of the Exchange apply equally to all Members.

The Exchange believes the proposal allows Floor Brokers the flexibility to execute orders that correct bona fide errors out of the Floor Broker's error account, ensuring that customer orders (which were previously entered in error) are executed, thereby protecting investors and the public interest by ensuring that customer orders are executed properly. Further, the Exchange believes the proposed rule promotes just and equitable principles of trade by ensuring customer orders are not harmed for order entry errors. The Exchange does not believe the proposed rule is unfairly discriminatory toward customers, issuers, or brokers because the proposed rule simply sets forth the process for Floor Brokers to correct certain bona fide errors. As discussed above, the Exchange believes that the proposed change is appropriate as it is similar to rules in place at other options exchanges with open outcry trading floors.¹² The Exchange also believes that this proposed rule change is non-discriminatory as it would apply equally to all Floor Brokers.

B. Self-Regulatory Organization's Statement on Burden on Competition

The Exchange does not believe that the proposed rule change will impose any burden on competition not necessary or appropriate in furtherance of the purposes of the Act. Specifically, the Exchange does not believe that the proposed rule change will impose any burden on intra-market competition because the proposed change to

Exchange Rule 100 is non-substantive and only provides additional clarity to the Exchange's rule text. The Exchange does not believe that proposed rule 2005 will impose any burden on intra-market competition because the proposed rule will be applicable to all Floor Brokers. In addition, the Exchange does not believe that the proposed change will impose any burden on inter-market competition because the proposed change to Rule 100 is to provide clarity in the Exchange's rule and is not competitive in nature and proposed Rule 2005 simply provides a mechanism for correcting errors. Further, the Exchange believes that proposed Rule 2005 does not impose a burden on competition because it simply sets forth the process for Floor Brokers to correct bona fide errors on the Trading Floor.

C. Self-Regulatory Organization's Statement on Comments on the Proposed Rule Change Received From Members, Participants, or Others

Written comments were neither solicited nor received.

III. Date of Effectiveness of the Proposed Rule Change and Timing for Commission Action

Because the foregoing proposed rule change does not: (i) significantly affect the protection of investors or the public interest; (ii) impose any significant burden on competition; and (iii) become operative for 30 days from the date on which it was filed, or such shorter time as the Commission may designate, it has become effective pursuant to Section 19(b)(3)(A) of the Act¹³ and Rule 19b-4(f)(6) thereunder.¹⁴

At any time within 60 days of the filing of the proposed rule change, the Commission summarily may temporarily suspend such rule change if it appears to the Commission that such action is necessary or appropriate in the public interest, for the protection of investors, or otherwise in furtherance of the purposes of the Act. If the Commission takes such action, the Commission shall institute proceedings to determine whether the proposed rule change should be approved or disapproved.

¹³ 15 U.S.C. 78s(b)(3)(A).

¹⁴ 17 CFR 240.19b-4(f)(6). In addition, Rule 19b-4(f)(6)(iii) requires a self-regulatory organization to give the Commission written notice of its intent to file the proposed rule change, along with a brief description and text of the proposed rule change, at least five business days prior to the date of filing of the proposed rule change, or such shorter time as designated by the Commission. The Exchange has satisfied this requirement.

IV. Solicitation of Comments

Interested persons are invited to submit written data, views, and arguments concerning the foregoing, including whether the proposed rule change is consistent with the Act. Comments may be submitted by any of the following methods:

Electronic Comments

- Use the Commission's internet comment form (<https://www.sec.gov/rules/sro.shtml>); or
- Send an email to rule-comments@sec.gov. Please include file number SR-SAPPHIRE-2025-15 on the subject line.

Paper Comments

- Send paper comments in triplicate to Secretary, Securities and Exchange Commission, 100 F Street NE, Washington, DC 20549-1090.

All submissions should refer to file number SR-SAPPHIRE-2025-15. This file number should be included on the subject line if email is used. To help the Commission process and review your comments more efficiently, please use only one method. The Commission will post all comments on the Commission's internet website (<https://www.sec.gov/rules/sro.shtml>). Copies of the submission, all subsequent amendments, all written statements with respect to the proposed rule change that are filed with the Commission, and all written communications relating to the proposed rule change between the Commission and any person, other than those that may be withheld from the public in accordance with the provisions of 5 U.S.C. 552, will be available for website viewing and printing in the Commission's Public Reference Room, 100 F Street NE, Washington, DC 20549 on official business days between the hours of 10 a.m. and 3 p.m. Copies of the filing also will be available for inspection and copying at the principal office of the Exchange. Do not include personal identifiable information in submissions; you should submit only information that you wish to make available publicly. We may redact in part or withhold entirely from publication submitted material that is obscene or subject to copyright protection. All submissions should refer to file number SR-SAPPHIRE-2025-15 and should be submitted on or before May 1, 2025.

¹¹ *Id.*

¹² See *supra* note 8.

For the Commission, by the Division of Trading and Markets, pursuant to delegated authority.¹⁵

Vanessa A. Countryman,
Secretary.

[FR Doc. 2025-06115 Filed 4-9-25; 8:45 am]

BILLING CODE 8011-01-P

SECURITIES AND EXCHANGE COMMISSION

[Release No. 34-102771; File No. SR-CboeEDGX-2025-027]

Self-Regulatory Organizations; Cboe EDGX Exchange, Inc.; Notice of Filing and Immediate Effectiveness of a Proposed Rule Change To Amend Its Fee Schedule To Introduce Clarifying Language for the Retail Equities Membership Program

April 4, 2025.

Pursuant to Section 19(b)(1) of the Securities Exchange Act of 1934 (“Act”),¹ and Rule 19b-4 thereunder,² notice is hereby given that on March 27, 2025, Cboe EDGX Exchange, Inc. (“Exchange” or “EDGX”) filed with the Securities and Exchange Commission (“Commission”) the proposed rule change as described in Items I, II, and III below, which Items have been prepared by the Exchange. The Commission is publishing this notice to solicit comments on the proposed rule change from interested persons.

I. Self-Regulatory Organization’s Statement of the Terms of Substance of the Proposed Rule Change

Cboe EDGX Exchange, Inc. (the “Exchange” or “EDGX”) proposes to amend its fee schedule to introduce clarifying language for the Retail Equities Membership Program. The text of the proposed rule change is provided in Exhibit 5.

The text of the proposed rule change is also available on the Exchange’s website (http://markets.cboe.com/us/options/regulation/rule_filings/edgx/), at the Exchange’s Office of the Secretary, and at the Commission’s Public Reference Room.

II. Self-Regulatory Organization’s Statement of the Purpose of, and Statutory Basis for, the Proposed Rule Change

In its filing with the Commission, the Exchange included statements concerning the purpose of and basis for the proposed rule change and discussed any comments it received on the

proposed rule change. The text of these statements may be examined at the places specified in Item IV below. The Exchange has prepared summaries, set forth in sections A, B, and C below, of the most significant aspects of such statements.

A. Self-Regulatory Organization’s Statement of the Purpose of, and Statutory Basis for, the Proposed Rule Change

1. Purpose

The Exchange proposes to amend its fee schedule to clarify the eligibility requirements for the EDGX Retail Membership Program (the “Program”). Specifically, the Exchange first proposes to note that a new Member may not have been approved as an EDGX Equities Exchange Retail Member Organization (“RMO”) within 18 months prior to approval as an RMO. Currently, the fee schedule specifies that to be eligible, a new Member may not have been approved as an EDGX Equities Exchange member within 18 months prior to approval as an RMO. The proposed change specifies that it is membership as an RMO specifically that is considered when determining the time eligibility requirements, meaning, that a participant that is an EDGX Equities Exchange member, and then later attains its status as an RMO, may be eligible for the program based on the timing of its admittance as an RMO. Additionally, the Exchange proposes to remove the sentence pertaining to membership eligibility for Members that were approved on or after January 1, 2021 as it is no longer relevant.

2. Statutory Basis

The Exchange believes the proposed rule change is consistent with the Securities Exchange Act of 1934 (the “Act”) and the rules and regulations thereunder applicable to the Exchange and, in particular, the requirements of Section 6(b) of the Act.³ Specifically, the Exchange believes the proposed rule change is consistent with the Section 6(b)(5)⁴ requirements that the rules of an exchange be designed to prevent fraudulent and manipulative acts and practices, to promote just and equitable principles of trade, to foster cooperation and coordination with persons engaged in regulating, clearing, settling, processing information with respect to, and facilitating transactions in securities, to remove impediments to and perfect the mechanism of a free and open market and a national market

system, and, in general, to protect investors and the public interest. Additionally, the Exchange believes the proposed rule change is consistent with the Section 6(b)(5)⁵ requirement that the rules of an exchange not be designed to permit unfair discrimination between customers, issuers, brokers, or dealers.

In particular, the Exchange believes that adding this clarifying language better sets forth the expectations for potential Program participants. The Exchange currently follows this timing (of basing the time eligibility of a Member’s status as an RMO member and not solely as a member). Additionally, the Exchange believes that by removing the dated reference to January 2021 (as it is no longer applicable), that it further provides clarity within the fee schedule. These updates are intended to align with current practices and manage expectations of potential Program participants. The proposed changes also apply uniformly to all prospective Program participants.

B. Self-Regulatory Organization’s Statement on Burden on Competition

The Exchange does not believe that the proposed rule change will impose any burden on competition that is not necessary or appropriate in furtherance of the purposes of the Act. This proposal does not create an unnecessary or inappropriate intra-market burden on competition because the proposed change will apply uniformly to all prospective Program participants. Further, the proposed change is not designed to address any competitive issues. Indeed, this proposal does not create an unnecessary or inappropriate inter-market burden on competition because it merely updates the process to clarify requirements for applicants inline with current business practices.

C. Self-Regulatory Organization’s Statement on Comments on the Proposed Rule Change Received From Members, Participants, or Others

The Exchange neither solicited nor received comments on the proposed rule change.

III. Date of Effectiveness of the Proposed Rule Change and Timing for Commission Action

The foregoing rule change has become effective pursuant to Section 19(b)(3)(A) of the Act⁶ and paragraph (f) of Rule 19b-4⁷ thereunder. At any time within 60 days of the filing of the proposed rule

¹⁵ 17 CFR 200.30-3(a)(12).

¹ 15 U.S.C. 78s(b)(1).

² 17 CFR 240.19b-4.

³ 15 U.S.C. 78f(b).

⁴ 15 U.S.C. 78f(b)(5).

⁵ *Id.*

⁶ 15 U.S.C. 78s(b)(3)(A).

⁷ 17 CFR 240.19b-4(f).

change, the Commission summarily may temporarily suspend such rule change if it appears to the Commission that such action is necessary or appropriate in the public interest, for the protection of investors, or otherwise in furtherance of the purposes of the Act. If the Commission takes such action, the Commission will institute proceedings to determine whether the proposed rule change should be approved or disapproved.

IV. Solicitation of Comments

Interested persons are invited to submit written data, views and arguments concerning the foregoing, including whether the proposed rule change is consistent with the Act. Comments may be submitted by any of the following methods:

Electronic Comments

- Use the Commission's internet comment form (<https://www.sec.gov/rules/sro.shtml>); or
- Send an email to rule-comments@sec.gov. Please include file number SR-CboeEDGX-2025-027 on the subject line.

Paper Comments

- Send paper comments in triplicate to Secretary, Securities and Exchange Commission, 100 F Street NE, Washington, DC 20549-1090.
- All submissions should refer to file number SR-CboeEDGX-2025-027. This file number should be included on the subject line if email is used. To help the Commission process and review your comments more efficiently, please use only one method. The Commission will post all comments on the Commission's internet website (<https://www.sec.gov/rules/sro.shtml>). Copies of the submission, all subsequent amendments, all written statements with respect to the proposed rule change that are filed with the Commission, and all written communications relating to the proposed rule change between the Commission and any person, other than those that may be withheld from the public in accordance with the provisions of 5 U.S.C. 552, will be available for website viewing and printing in the Commission's Public Reference Room, 100 F Street NE, Washington, DC 20549, on official business days between the hours of 10 a.m. and 3 p.m. Copies of the filing also will be available for inspection and copying at the principal office of the Exchange. Do not include personal identifiable information in submissions; you should submit only information that you wish to make available

publicly. We may redact in part or withhold entirely from publication submitted material that is obscene or subject to copyright protection. All submissions should refer to file number SR-CboeEDGX-2025-027 and should be submitted on or before May 1, 2025.

For the Commission, by the Division of Trading and Markets, pursuant to delegated authority.⁸

Vanessa A. Countryman,
Secretary.

[FR Doc. 2025-06114 Filed 4-9-25; 8:45 am]

BILLING CODE 8011-01-P

SECURITIES AND EXCHANGE COMMISSION

[OMB Control No. 3235-0496]

Submission for OMB Review; Comment Request; Extension: Appendix F to Rule 15c3-1

Upon Written Request, Copies Available From: Securities and Exchange Commission, Office of FOIA Services, 100 F Street NE, Washington, DC 20549-2736

Notice is hereby given that pursuant to the Paperwork Reduction Act of 1995 (44 U.S.C. 3501 *et seq.*) ("PRA"), the Securities and Exchange Commission ("Commission") is soliciting comments on the existing collection of information provided for in Appendix F to Rule 15c3-1 ("Appendix F" or "Rule 15c3-1f") (17 CFR 240.15c3-1f) under the Securities Exchange Act of 1934 (15 U.S.C. 78a *et seq.*) ("Exchange Act").

Appendix F applies to certain members of a class of broker-dealers known as over-the-counter ("OTC") derivatives dealers. Exchange Act Rule 15c3-1 is the Commission's net capital rule for broker-dealers.¹ Under Appendix F, an OTC derivatives dealer that is not a security-based swap dealer may apply to the Commission for authorization to compute net capital charges for market and credit risk in accordance with Appendix F in lieu of computing securities haircuts under paragraph (c)(2)(vi) of Exchange Act Rule 15c3-1.²

At present, two OTC derivatives dealers have been approved to use Appendix F. No additional OTC derivatives dealers have applied to use

⁸ 17 CFR 200.30-3(a)(12).

¹ 17 CFR 240.15c3-1. An OTC derivatives dealer that is also registered as a security-based swap dealer is subject to the net capital provisions of Exchange Act Rule 18a-1 (17 CFR 240.18a-1).

² An OTC derivatives dealer that is also registered as a security-based swap dealer may apply to the Commission for authorization to compute deductions for market and credit risk using models under paragraph (d) of Rule 18a-1.

Appendix F, and the staff does not expect that any additional OTC derivatives dealers will apply to use Appendix F during the next three years. The Commission estimates that the two approved OTC derivatives dealers will spend an average of approximately 1,000 hours each per year reporting information concerning their value-at-risk ("VAR") models and internal risk management systems, for a total annual burden of approximately 2,000 hours.

An agency may not conduct or sponsor, and a person is not required to respond to, a collection of information unless it displays a currently valid OMB Control Number.

Written comments are invited on: (a) whether this collection of information is necessary for the proper performance of the functions of the agency, including whether the information will have practical utility; (b) the accuracy of the agency's estimate of the burden imposed by the collection of information; (c) ways to enhance the quality, utility, and clarity of the information collected; and (d) ways to minimize the burden of the collection of information on respondents, including through the use of automated collection techniques or other forms of information technology.

The public may view and comment on this information collection request at: https://www.reginfo.gov/public/do/PRAViewICR?ref_nbr=202501-3235-030 or send an email comment to MBX.OMB.OIRA.SEC_desk_officer@omb.eop.gov within 30 days of the day after publication of this notice by May 12, 2025.

Dated: April 7, 2025.

Sherry R. Haywood,
Assistant Secretary.

[FR Doc. 2025-06128 Filed 4-9-25; 8:45 am]

BILLING CODE 8011-01-P

SMALL BUSINESS ADMINISTRATION

[License No. 04/04-0332]

KLH Capital Fund III, L.P.; Surrender of License of Small Business Investment Company

Pursuant to the authority granted to the United States Small Business Administration under Section 309 of the Small Business Investment Act of 1958, as amended, and 13 CFR 107.1900 of the Code of Federal Regulations to function as a small business investment company under the Small Business Investment Company license number 04/04-0332 issued to KLH Capital Fund III, L.P.,

said license is hereby declared null and void.

Paul Salgado,

*Director, Investment Portfolio Management,
U.S. Small Business Administration.*

[FR Doc. 2025-06154 Filed 4-9-25; 8:45 am]

BILLING CODE P

DEPARTMENT OF STATE

[Public Notice: 12693]

Notice of Determinations; Culturally Significant Objects Being Imported for Exhibition—Determinations: “The Many Lives of the Nakagin Capsule Tower” Exhibition

SUMMARY: Notice is hereby given of the following determinations: I hereby determine that certain objects being imported from abroad pursuant to agreements with their foreign owners or custodians for temporary display in the exhibition “The Many Lives of the Nakagin Capsule Tower” at The Museum of Modern Art, New York, New York, and at possible additional exhibitions or venues yet to be determined, are of cultural significance, and, further, that their temporary exhibition or display within the United States as aforementioned is in the national interest. I have ordered that Public Notice of these determinations be published in the **Federal Register**.

FOR FURTHER INFORMATION CONTACT: Reed Liriano, Program Coordinator, Office of the Legal Adviser, U.S. Department of State (telephone: 202-632-6471; email: section2459@state.gov). The mailing address is U.S. Department of State, L/DP, 2200 C Street NW (SA-5), Suite 5H03, Washington, DC 20522-0505.

SUPPLEMENTARY INFORMATION: The foregoing determinations were made pursuant to the authority vested in me by the Act of October 19, 1965 (79 Stat. 985; 22 U.S.C. 2459), Executive Order 12047 of March 27, 1978, the Foreign Affairs Reform and Restructuring Act of 1998 (112 Stat. 2681, *et seq.*; 22 U.S.C. 6501 note, *et seq.*), Delegation of Authority No. 234 of October 1, 1999, Delegation of Authority No. 236-3 of August 28, 2000, and Delegation of Authority No. 574 of March 4, 2025.

Mary C. Miner,

Managing Director for Professional and Cultural Exchanges, Bureau of Educational and Cultural Affairs, Department of State.

[FR Doc. 2025-06148 Filed 4-9-25; 8:45 am]

BILLING CODE 4710-05-P

DEPARTMENT OF STATE

[Public Notice: 12694]

Notice of Determinations; Culturally Significant Objects Being Imported for Exhibition—Determinations: “Takashi Murakami: Stepping on the Tail of a Rainbow” Exhibition

SUMMARY: Notice is hereby given of the following determinations: I hereby determine that certain objects being imported from abroad pursuant to an agreement with their foreign owner or custodian for temporary display in the exhibition “Takashi Murakami: Stepping on the Tail of a Rainbow” at The Cleveland Museum of Art, Cleveland, Ohio, and at possible additional exhibitions or venues yet to be determined, are of cultural significance, and, further, that their temporary exhibition or display within the United States as aforementioned is in the national interest. I have ordered that Public Notice of these determinations be published in the **Federal Register**.

FOR FURTHER INFORMATION CONTACT: Reed Liriano, Program Coordinator, Office of the Legal Adviser, U.S. Department of State (telephone: 202-632-6471; email: section2459@state.gov). The mailing address is U.S. Department of State, L/DP, 2200 C Street NW (SA-5), Suite 5H03, Washington, DC 20522-0505.

SUPPLEMENTARY INFORMATION: The foregoing determinations were made pursuant to the authority vested in me by the Act of October 19, 1965 (79 Stat. 985; 22 U.S.C. 2459), Executive Order 12047 of March 27, 1978, the Foreign Affairs Reform and Restructuring Act of 1998 (112 Stat. 2681, *et seq.*; 22 U.S.C. 6501 note, *et seq.*), Delegation of Authority No. 234 of October 1, 1999, Delegation of Authority No. 236-3 of August 28, 2000, and Delegation of Authority No. 574 of March 4, 2025.

Mary C. Miner,

Managing Director for Professional and Cultural Exchanges, Bureau of Educational and Cultural Affairs, Department of State.

[FR Doc. 2025-06147 Filed 4-9-25; 8:45 am]

BILLING CODE 4710-05-P

SUSQUEHANNA RIVER BASIN COMMISSION

Grandfathering Registration Notice

AGENCY: Susquehanna River Basin Commission.

ACTION: Notice.

SUMMARY: This notice lists Grandfathering Registration for projects by the Susquehanna River Basin Commission during the period set forth in **DATES**.

DATES: March 1–31, 2025.

ADDRESSES: Susquehanna River Basin Commission, 4423 North Front Street, Harrisburg, PA 17110-1788.

FOR FURTHER INFORMATION CONTACT: Jason E. Oyler, General Counsel and Secretary to the Commission, telephone: (717) 238-0423, ext. 1312; fax: (717) 238-2436; email: joyler@srbc.gov. Regular mail inquiries may be sent to the above address.

SUPPLEMENTARY INFORMATION: This notice lists GF Registration for projects, described below, pursuant to 18 CFR part 806, subpart E, for the time period specified above:

1. Village of Candor, GF Certificate No. GF-202503290, Village of Candor, Tioga County, N.Y.; Morrow Well, Ward Well, and combined withdrawals from the Morrow Well and Ward Well; Issue Date: March 7, 2025.

2. Huntsinger Farms, Inc., GF Certificate No. GF-202503291, Heginns and Hubley Townships, Schuylkill County, Pa.; Deep Creek 1, Deep Creek 2, Pine Creek 1, Pine Creek 2, and Monroes Pond; Reissue Date: March 13, 2025.

Authority: Public Law 91-575, 84 Stat. 1509 *et seq.*, 18 CFR parts 806 and 808.

Dated: April 7, 2025.

Jason E. Oyler,

General Counsel and Secretary to the Commission.

[FR Doc. 2025-06132 Filed 4-9-25; 8:45 am]

BILLING CODE 7040-01-P

SUSQUEHANNA RIVER BASIN COMMISSION

Projects Approved for Consumptive Uses of Water

AGENCY: Susquehanna River Basin Commission.

ACTION: Notice.

SUMMARY: This notice lists Approvals by Rule for projects by the Susquehanna River Basin Commission during the period set forth in **DATES**.

DATES: March 1–31, 2025.

ADDRESSES: Susquehanna River Basin Commission, 4423 North Front Street, Harrisburg, PA 17110-1788.

FOR FURTHER INFORMATION CONTACT: Jason E. Oyler, General Counsel and Secretary to the Commission, telephone: (717) 238-0423, ext. 1312; fax: (717) 238-2436; email: joyler@srbc.gov.

Regular mail inquiries may be sent to the above address.

SUPPLEMENTARY INFORMATION: This notice lists the projects, described below, receiving approval for the consumptive use of water pursuant to the Commission's approval by rule process set forth in 18 CFR 806.22(e) and (f) for the time period specified above.

Approvals by Rule—Issued Under 18 CFR 806.22(e)

1. Country Club of York; ABR–202503002; Spring Garden Township, York County, Pa.; Consumptive Use of Up to 0.4500 mgd; Approval Date: March 21, 2025.

Approvals by Rule—Issued Under 18 CFR 806.22(f)

1. RENEWAL—Coterra Energy Inc.; Pad ID: ReynenJ P1; ABR–201412002.R2; Harford Township, Susquehanna County, Pa.; Consumptive Use of Up to 5.0000 mgd; Approval Date: March 18, 2025.

2. RENEWAL—Expand Operating LLC; Pad ID: NR–20–COLWELL–PAD; ABR–201407010.R2; Oakland Township, Susquehanna County, Pa.; Consumptive Use of Up to 7.5000 mgd; Approval Date: March 18, 2025.

3. RENEWAL—LPR Energy, LLC; Pad ID: Lytle Unit Drilling Pad #1H; ABR–20100104.R3; Lawrence Township, Clearfield County, Pa.; Consumptive Use of Up to 5.0000 mgd; Approval Date: March 18, 2025.

4. RENEWAL—Repsol Oil & Gas USA, LLC; Pad ID: Bowers 408; ABR–20090919.R3; Jackson Township, Tioga County, Pa.; Consumptive Use of Up to 6.0000 mgd; Approval Date: March 18, 2025.

5. RENEWAL—Repsol Oil & Gas USA, LLC; Pad ID: CASTLE (01 047) J; ABR–20100128.R3; Armenia Township, Bradford County, Pa.; Consumptive Use of Up to 6.0000 mgd; Approval Date: March 18, 2025.

6. RENEWAL—Repsol Oil & Gas USA, LLC; Pad ID: Castle 113D; ABR–20100123.R3; Canton Township, Bradford County, Pa.; Consumptive Use of Up to 6.0000 mgd; Approval Date: March 18, 2025.

7. RENEWAL—Repsol Oil & Gas USA, LLC; Pad ID: HOOVER (01 017) G; ABR–20100108.R3; Canton Township, Bradford County, Pa.; Consumptive Use of Up to 6.0000 mgd; Approval Date: March 18, 2025.

8. RENEWAL—Repsol Oil & Gas USA, LLC; Pad ID: Miller 116D; ABR–20100124.R3; Union Township, Tioga County, Pa.; Consumptive Use of Up to 6.0000 mgd; Approval Date: March 18, 2025.

9. RENEWAL—Repsol Oil & Gas USA, LLC; Pad ID: THOMAS (01 001) FT; ABR–20100112.R3; Troy Township, Bradford County, Pa.; Consumptive Use of Up to 6.0000 mgd; Approval Date: March 18, 2025.

10. RENEWAL—Repsol Oil & Gas USA, LLC; Pad ID: THOMAS (01 002) FT; ABR–20100113.R3; Troy Township, Bradford County, Pa.; Consumptive Use of Up to 6.0000 mgd; Approval Date: March 18, 2025.

11. RENEWAL—Repsol Oil & Gas USA, LLC; Pad ID: TWL ASSOC (01 016); ABR–20100129.R3; Armenia Township, Bradford County, Pa.; Consumptive Use of Up to 6.0000 mgd; Approval Date: March 18, 2025.

12. RENEWAL—Repsol Oil & Gas USA, LLC; Pad ID: VANBLARCOM (03 004) R; ABR–20100103.R3; Columbia Township, Bradford County, Pa.; Consumptive Use of Up to 6.0000 mgd; Approval Date: March 18, 2025.

13. RENEWAL—Seneca Resources Company, LLC; Pad ID: Chapman 237; ABR–20091206.R3; Sullivan Township, Tioga County, Pa.; Consumptive Use of Up to 4.0000 mgd; Approval Date: March 18, 2025.

14. RENEWAL—Seneca Resources Company, LLC; Pad ID: Willard 419–1H; ABR–20100105.R3; Delmar Township, Tioga County, Pa.; Consumptive Use of Up to 4.0000 mgd; Approval Date: March 18, 2025.

15. Blackhill Energy LLC; Pad ID: Black Jack Sparrow; ABR–202503001; Springfield Township, Bradford County, Pa.; Consumptive Use of Up to 6.5000 mgd; Approval Date: March 21, 2025.

16. MODIFICATION—Expand Operating LLC; Pad ID: Coyle Well Pad; ABR–201205006.R2.1; Liberty Township, Susquehanna County, Pa.; Consumptive Use of Up to 7.5000 mgd; Approval Date: March 21, 2025.

17. MODIFICATION—Expand Operating LLC; Pad ID: NR–14–BRANT–PAD; ABR–201312001.R2.1; Great Bend Township, Susquehanna County, Pa.; Consumptive Use of Up to 7.5000 mgd; Approval Date: March 21, 2025.

18. RENEWAL—BKV Operating, LLC; Pad ID: Procter & Gamble Mehoopany Plant 3V; ABR–20100126.R3; Washington Township, Wyoming County, Pa.; Consumptive Use of Up to 5.0000 mgd; Approval Date: March 27, 2025.

19. RENEWAL—Expand Operating LLC; Pad ID: Bartz; ABR–202003002.R1; Monroe Township, Bradford County, Pa.; Consumptive Use of Up to 7.5000 mgd; Approval Date: March 27, 2025.

20. RENEWAL—Expand Operating LLC; Pad ID: Grippo; ABR–20091212.R3; Terry Township, Bradford County, Pa.; Consumptive Use of Up to

7.5000 mgd; Approval Date: March 27, 2025.

21. RENEWAL—Expand Operating LLC; Pad ID: Popivchak; ABR–20100147.R3; Burlington Township, Bradford County, Pa.; Consumptive Use of Up to 7.5000 mgd; Approval Date: March 27, 2025.

22. RENEWAL—Expand Operating LLC; Pad ID: Roger; ABR–20091209.R3; Rush Township, Susquehanna County, Pa.; Consumptive Use of Up to 7.5000 mgd; Approval Date: March 27, 2025.

23. RENEWAL—Expand Operating LLC; Pad ID: Stevens; ABR–20100151.R3; Standing Stone Township, Bradford County, Pa.; Consumptive Use of Up to 7.5000 mgd; Approval Date: March 27, 2025.

24. RENEWAL—Expand Operating LLC; Pad ID: Teel Unit Drilling Pad #2H; ABR–20091204.R3; Springville Township, Susquehanna County, Pa.; Consumptive Use of Up to 7.5000 mgd; Approval Date: March 27, 2025.

25. RENEWAL—Expand Operating LLC; Pad ID: Teel Unit Drilling Pad #3H; ABR–20091205.R3; Springville Township, Susquehanna County, Pa.; Consumptive Use of Up to 7.5000 mgd; Approval Date: March 27, 2025.

26. RENEWAL—Expand Operating LLC; Pad ID: Walters Unit #1H; ABR–20100135.R3; West Burlington Township, Bradford County, Pa.; Consumptive Use of Up to 7.5000 mgd; Approval Date: March 27, 2025.

27. RENEWAL—Repsol Oil & Gas USA, LLC; Pad ID: EICK (03 013) W; ABR–20091105.R3; Columbia Township, Bradford County, Pa.; Consumptive Use of Up to 6.0000 mgd; Approval Date: March 27, 2025.

28. RENEWAL—Repsol Oil & Gas USA, LLC; Pad ID: FOUST (01 003) J; ABR–20100109.R3; Granville Township, Bradford County, Pa.; Consumptive Use of Up to 6.0000 mgd; Approval Date: March 27, 2025.

29. RENEWAL—S.T.L. Resources, LLC; Pad ID: Kjelgaard Pad; ABR–20090902.R3; Gaines Township, Tioga County, Pa.; Consumptive Use of Up to 4.0000 mgd; Approval Date: March 27, 2025.

30. RENEWAL—Seneca Resources Company, LLC; Pad ID: Brown 425; ABR–20091106.R3; Delmar and Shippen Townships, Tioga County, Pa.; Consumptive Use of Up to 4.0000 mgd; Approval Date: March 27, 2025.

31. RENEWAL—Seneca Resources Company, LLC; Pad ID: Butler 127; ABR–20100114.R3; Delmar Township, Tioga County, Pa.; Consumptive Use of Up to 4.0000 mgd; Approval Date: March 27, 2025.

32. RENEWAL—Seneca Resources Company, LLC; Pad ID: Hackman 143;

ABR-20100118.R3; Delmar Township, Tioga County, Pa.; Consumptive Use of Up to 4.0000 mgd; Approval Date: March 27, 2025.

33. RENEWAL—Seneca Resources Company, LLC; Pad ID: Jenkins 523; ABR-20091215.R3; Rutland Township, Tioga County, Pa.; Consumptive Use of Up to 4.0000 mgd; Approval Date: March 27, 2025.

34. RENEWAL—Seneca Resources Company, LLC; Pad ID: Pannebaker 515; ABR-20091216.R3; Rutland Township, Tioga County, Pa.; Consumptive Use of Up to 4.0000 mgd; Approval Date: March 27, 2025.

35. RENEWAL—Seneca Resources Company, LLC; Pad ID: Phillips 504; ABR-20091018.R3; Rutland Township, Tioga County, Pa.; Consumptive Use of Up to 4.0000 mgd; Approval Date: March 27, 2025.

36. RENEWAL—Seneca Resources Company, LLC; Pad ID: Stehmer 420; ABR-20091101.R3; Delmar Township, Tioga County, Pa.; Consumptive Use of Up to 4.0000 mgd; Approval Date: March 27, 2025.

37. RENEWAL—Seneca Resources Company, LLC; Pad ID: West 299; ABR-20091111.R3; Richmond Township, Tioga County, Pa.; Consumptive Use of Up to 4.0000 mgd; Approval Date: March 27, 2025.

38. RENEWAL—BKV Operating, LLC; Pad ID: Procter & Gamble Mehoopany Plant 4V; ABR-20100125.R3; Washington Township, Wyoming County, Pa.; Consumptive Use of Up to 5.0000 mgd; Approval Date: March 30, 2025.

39. RENEWAL—BKV Operating, LLC; Pad ID: Procter & Gamble Mehoopany Plant 5V; ABR-20100127.R3; Washington Township, Wyoming County, Pa.; Consumptive Use of Up to 5.0000 mgd; Approval Date: March 30, 2025.

40. RENEWAL—Expand Operating LLC; Pad ID: Jads; ABR-202003003.R1; Monroe Township, Bradford County, Pa.; Consumptive Use of Up to 7.5000 mgd; Approval Date: March 30, 2025.

41. RENEWAL—LPR Energy, LLC; Pad ID: Hodge Unit Drilling Pad #1; ABR-20091201.R3; Juniata Township, Blair County, Pa.; Consumptive Use of Up to 5.0000 mgd; Approval Date: March 30, 2025.

42. RENEWAL—Range Resources—Appalachia, LLC; Pad ID: Cornwall 6H-8H; ABR-201407017.R2; Lewis and Cogan House Townships, Lycoming County, Pa.; Consumptive Use of Up to 4.0000 mgd; Approval Date: March 30, 2025.

43. RENEWAL—Blackhill Energy LLC; Pad ID: LEE 1H; ABR-20091122.R3; Springfield Township,

Bradford County, Pa.; Consumptive Use of Up to 1.9990 mgd; Approval Date: March 31, 2025.

44. RENEWAL—Blackhill Energy LLC; Pad ID: LEE 3H; ABR-20091124.R3; Springfield Township, Bradford County, Pa.; Consumptive Use of Up to 1.9990 mgd; Approval Date: March 31, 2025.

45. RENEWAL—Coterra Energy Inc.; Pad ID: Baker P1; ABR-20100149.R3; Dimock Township, Susquehanna County, Pa.; Consumptive Use of Up to 5.0000 mgd; Approval Date: March 31, 2025.

46. RENEWAL—Expand Operating LLC; Pad ID: Bacon Drilling Pad #1; ABR-20100202.R3; Burlington Township, Bradford County, Pa.; Consumptive Use of Up to 7.5000 mgd; Approval Date: March 31, 2025.

47. RENEWAL—Expand Operating LLC; Pad ID: Elliott Drilling Pad #1H; ABR-20100136.R3; Monroe Township, Bradford County, Pa.; Consumptive Use of Up to 7.5000 mgd; Approval Date: March 31, 2025.

48. RENEWAL—Expand Operating LLC; Pad ID: Harper; ABR-20100142.R3; Terry Township, Bradford County, Pa.; Consumptive Use of Up to 7.5000 mgd; Approval Date: March 31, 2025.

49. RENEWAL—Expand Operating LLC; Pad ID: Knosky Pad Site; ABR-20090915.R3; Middletown and Rush Townships, Susquehanna County, Pa.; Consumptive Use of Up to 7.5000 mgd; Approval Date: March 31, 2025.

50. RENEWAL—Expand Operating LLC; Pad ID: Meas; ABR-20100134.R3; Albany Township, Bradford County, Pa.; Consumptive Use of Up to 7.5000 mgd; Approval Date: March 31, 2025.

51. RENEWAL—Expand Operating LLC; Pad ID: Mowry2; ABR-20100141.R3; Tuscarora Township, Bradford County, Pa.; Consumptive Use of Up to 7.5000 mgd; Approval Date: March 31, 2025.

52. RENEWAL—Expand Operating LLC; Pad ID: NR-16 HALEY PAD; ABR-201412006.R2; Great Bend Township, Susquehanna County, Pa.; Consumptive Use of Up to 7.5000 mgd; Approval Date: March 31, 2025.

53. RENEWAL—Expand Operating LLC; Pad ID: NR-18 Oak Ridge Pad; ABR-201501002.R2; Oakland Township, Susquehanna County, Pa.; Consumptive Use of Up to 7.5000 mgd; Approval Date: March 31, 2025.

54. RENEWAL—Expand Operating LLC; Pad ID: NR-23-FOUR BUCKS-PAD; ABR-201408005.R2; Great Bend and Oakland Townships, Susquehanna County, Pa.; Consumptive Use of Up to 7.5000 mgd; Approval Date: March 31, 2025.

55. RENEWAL—Expand Operating LLC; Pad ID: Stoorza; ABR-20091208.R3; Terry Township, Bradford County, Pa.; Consumptive Use of Up to 7.5000 mgd; Approval Date: March 31, 2025.

56. RENEWAL—Expand Operating LLC; Pad ID: Storms; ABR-20100131.R3; Tuscarora Township, Bradford County, Pa.; Consumptive Use of Up to 7.5000 mgd; Approval Date: March 31, 2025.

57. RENEWAL—Repsol Oil & Gas USA, LLC; Pad ID: Busia 457; ABR-20091016.R3; Jackson Township, Tioga County, Pa.; Consumptive Use of Up to 6.0000 mgd; Approval Date: March 31, 2025.

58. RENEWAL—Repsol Oil & Gas USA, LLC; Pad ID: LUTZ (01 007) T; ABR-20100111.R3; Troy Township, Bradford County, Pa.; Consumptive Use of Up to 6.0000 mgd; Approval Date: March 31, 2025.

Authority: Public Law 91-575, 84 Stat. 1509 *et seq.*, 18 CFR parts 806 and 808.

Dated: April 7, 2025.

Jason E. Oyler,

General Counsel and Secretary to the Commission.

[FR Doc. 2025-06130 Filed 4-9-25; 8:45 am]

BILLING CODE 7040-01-P

SUSQUEHANNA RIVER BASIN COMMISSION

General Permit Notice

AGENCY: Susquehanna River Basin Commission.

ACTION: Notice.

SUMMARY: This notice lists General Permits approved by the Susquehanna River Basin Commission during the period set forth in **DATES**.

DATES: March 1-31, 2025.

ADDRESSES: Susquehanna River Basin Commission, 4423 North Front Street, Harrisburg, PA 17110-1788.

FOR FURTHER INFORMATION CONTACT: Jason E. Oyler, General Counsel and Secretary to the Commission, telephone: (717) 238-0423, ext. 1312; fax (717) 238-2436; email: joyler@srbc.gov. Regular mail inquiries may be sent to the above address.

SUPPLEMENTARY INFORMATION: This notice lists General Permits for projects, described below, pursuant to 18 CFR 806.17(c)(4), for the time period specified above.

1. Susquehanna Nuclear, LLC—Susquehanna Steam Electric Station—Well TW-1, General Permit Approval of Coverage No. GP-02-202503010, Salem

Township, Luzerne County, Pa.; emergency/maintenance operations approved up to 0.072 mgd (30-day average); Approval Date: March 13, 2025.

Authority: Public Law 91–575, 84 Stat. 1509 *et seq.*, 18 CFR parts 806 and 808.

Dated: April 7, 2025.

Jason E. Oyler,

General Counsel and Secretary to the Commission.

[FR Doc. 2025–06131 Filed 4–9–25; 8:45 am]

BILLING CODE 7040–01–P

DEPARTMENT OF TRANSPORTATION

National Highway Traffic Safety Administration

[Docket No. NHTSA–2025–0025]

Agency Information Collection Activities; Notice and Request for Comment; Investigation-Based Crash Data Studies

AGENCY: National Highway Traffic Safety Administration (NHTSA), Department of Transportation (DOT).

ACTION: Notice and request for comments on an extension with modification of a currently approved information collection.

SUMMARY: The National Highway Traffic Safety Administration (NHTSA) invites public comments about our intention to request approval from the Office of Management and Budget (OMB) for extension with modification of a currently approved information collection. Before a Federal agency can collect certain information from the public, it must receive approval from OMB. Under procedures established by the Paperwork Reduction Act of 1995, before seeking OMB approval, Federal agencies must solicit public comment on proposed collections of information, including extensions and reinstatement of previously approved collections. This document describes a collection of information for which NHTSA intends to seek OMB approval on NHTSA's Investigation-Based Crash Data Studies: Crash Investigation Sampling System (CISS), Special Crash Investigation (SCI) and Special Study Data Collection.

DATES: Comments must be submitted on or before June 9, 2025.

ADDRESSES: You may submit comments identified by the Docket No. NHTSA–2025–0025 through any of the following methods:

- *Electronic submissions:* Go to the Federal eRulemaking Portal at <https://www.regulations.gov>. Follow the online instructions for submitting comments.

www.regulations.gov. Follow the online instructions for submitting comments.

- *Fax:* (202) 493–2251.

- *Mail or Hand Delivery:* Docket Management, U.S. Department of Transportation, 1200 New Jersey Avenue SE, West Building, Room W12–140, Washington, DC 20590, between 9 a.m. and 5 p.m., Monday through Friday, except on Federal holidays. To be sure someone is there to help you, please call (202) 366–9322 before coming.

Instructions: All submissions must include the agency name and docket number for this notice. Note that all comments received will be posted without change to <http://www.regulations.gov>, including any personal information provided. Please see the Privacy Act heading below.

Privacy Act: Anyone is able to search the electronic form of all comments received into any of our dockets by the name of the individual submitting the comment (or signing the comment, if submitted on behalf of an association, business, labor union, etc.). You may review DOT's complete Privacy Act Statement in the **Federal Register** published on April 11, 2000 (65 FR 19477–78) or you may visit <https://www.transportation.gov/privacy>.

Docket: For access to the docket to read background documents or comments received, go to <https://www.regulations.gov> or the street address listed above. Follow the online instructions for accessing the dockets via internet.

FOR FURTHER INFORMATION CONTACT: For additional information or access to background documents, contact Dinesh Sharma, Crash Investigation Division (NSA–110), (202) 366–2333, National Highway Traffic Safety Administration, W53–493, U.S. Department of Transportation, 1200 New Jersey Avenue SE, Washington, DC 20590. Please identify the relevant collection of information by referring to its OMB Control Number.

SUPPLEMENTARY INFORMATION: Under the Paperwork Reduction Act of 1995 (44 U.S.C. 3501 *et seq.*), before an agency submits a proposed collection of information to OMB for approval, it must first publish a document in the **Federal Register** providing a 60-day comment period and otherwise consult with members of the public and affected agencies concerning each proposed collection of information. The OMB has promulgated regulations describing what must be included in such a document. Under OMB's regulation (at 5 CFR 1320.8(d)), an agency must ask for public comment on the following: (a)

whether the proposed collection of information is necessary for the proper performance of the functions of the agency, including whether the information will have practical utility; (b) the accuracy of the agency's estimate of the burden of the proposed collection of information, including the validity of the methodology and assumptions used; (c) how to enhance the quality, utility, and clarity of the information to be collected; and (d) how to minimize the burden of the collection of information on those who are to respond, including the use of appropriate automated, electronic, mechanical, or other technological collection techniques or other forms of information technology, e.g., permitting electronic submission of responses. In compliance with these requirements, NHTSA asks for public comments on the following proposed collection of information for which the agency is seeking approval from OMB.

Title: Investigation-Based Crash Data Studies.

OMB Control Number: 2127–0706.

Form Number(s): Form 1278, 1280, 2046, 2047, 2048, 2049, HS Form 433D.

Type of Request: Request for extension with modification of a currently approved information collection.

Type of Review Requested: Regular.

Requested Expiration Date of Approval: 3 years from date of approval.

Summary of the Collection of Information: NHTSA is authorized, under 49 U.S.C. 30182 and 23 U.S.C. 403 to collect data on motor vehicle traffic crashes to aid in the identification of issues and the development, implementation, and evaluation of motor vehicle and highway safety countermeasures. For decades, NHTSA has been investigating crashes and collecting crash data through its Investigation-Based Crash Data Studies, namely the Crash Investigation Sampling System (CISS), Special Crash Investigation (SCI), and specific issue-based Special Study data collection studies. Although each of these systems satisfy different purposes and collect data in different manners, they all utilize the same core variables (e.g., forms), procedures and protocols for data collection.

NHTSA is seeking approval to modify the existing information collection to:

1. Increase the number of data collection sites to 73;
2. Expand the type of crashes investigated to include non-motorists, motorcycles and large vehicles (over 10,000 pounds gross vehicle weight rating) for 2025 and future years.

NHTSA has also adjusted estimates to include the burden incurred by tow

yards, hospitals, and law enforcement agencies in responding to the collections from the currently approved 56 to 73 data collection sites over the next three years. The Infrastructure Investment and Jobs Act requested that the Crash Investigation Sampling System (CISS) expand the number of data collection sites; include more crash types (non-motorists, motorcycles and large vehicles) and explore on-scene response. The current approval for Investigation-Based Crash Data Studies collection indicated a total annual 12,063 burden hours; this request increases the total annual burden hours to 17,521. The combined impact is an increase of 5,458 hours overall total annual burden from the currently approved information collection. The increase in burden hours and cost for these additional data collection sites are reflected in the Burden to Respondent section of this document.

The CISS is a nationally representative sample of passenger vehicle crashes which focus on detailed investigation of passenger vehicle crashes, pedestrian crashes and motorcycle crashes. It provides nationally representative data on fatal and nonfatal motor vehicle, pedestrian and motorcycle crashes for use in developing and evaluating federal motor vehicle safety standards and other safety countermeasures. The CISS began implementation in 2015 and by 2024 was collecting crash data from forty (40) fully operational sites. In 2024 the CISS started collecting data on pedestrian crashes. The CISS will start collecting data on motorcycle crashes in 2025 and large vehicle crashes in 2026. The CISS collects data at both the crash level through scene analysis and vehicle level through vehicle damage assessment together with injury source evidence and standardized coding.

The SCI Program is used to provide NHTSA with the most in-depth and detailed level of crash investigation data collected by the Agency. Generally, SCI investigations are conducted for crashes of special interest, such as those involving new or emerging safety technologies (e.g., those involving vehicles equipped with crash avoidance technologies or Automated Driving Systems (ADS)), school buses, motorcoaches, alternative fuel and hybrid vehicles, adaptive control equipped vehicles, fires, child restraints, and those relevant to safety defect investigations. The crash investigations are conducted to document crash circumstances, identify injury sources, evaluate safety countermeasure effectiveness and support Agency rulemaking actions.

Investigations are also conducted to provide early detection of alleged or potential vehicle safety defects. Reports are generated from investigations and all are made available to the public. The crashes chosen for SCI investigation may be chosen throughout the year as they arise, or be part of a planned effort to look into a particular type of crash (such as crashes involving air bag deployment-related fatalities and injuries).

In addition to the above-referenced CISS and SCI data collections, NHTSA also conducts investigation-based special studies using the CISS and SCI infrastructure to answer questions on a specific topical aspect of vehicle and highway safety. In the special study cases, data is typically gathered remotely where documents and investigation details are requested from investigating agencies and the data is compiled, coded, and reported on collectively in a summary report detailing the issue. These special studies will utilize the same infrastructure CISS and SCI, as well as the same core variables (e.g., forms) and procedures and protocols. The cases may be selected from an agency's data set (i.e., CISS, SCI, or Fatality Analysis Reporting System (FARS)) or through other means (i.e., internet searches, news articles, and public notification). The cases may or may not be selected to provide a nationally representative sample of crashes. In the past, using the National Automotive Sampling System-Crashworthiness Data System (NASS-CDS) infrastructure, NHTSA conducted several investigation-based special studies, including studies on child occupant protection, air bag effectiveness, and pedestrian safety among others. NASS-CDS, operated from 1979 through 2015, and was the predecessor to CISS. Two recently completed special studies collected information on crashes that involved medium-duty trucks (trucks between 10,001 and 26,000 lbs.), pedestrians or pedalcyclists, and one in-progress special study is on first responders or construction or maintenance workers struck while performing official duties on the road.

NHTSA will also use the information collected through the CISS infrastructure to support NHTSA's Non-Traffic Surveillance (NTS). CISS Technicians review over a hundred and fifty thousand crash reports each year, and some of these reports are not applicable to the CISS program, but they may be applicable to the NTS data collection. NTS is a virtual data collection system designed to provide counts and details regarding fatalities

and injuries that occur in non-traffic crashes and in non-crash incidents. Non-traffic motor vehicle crashes are a class of crashes that occur off the public trafficways. These crashes, subsequently referred to as "non-traffic crashes," are mostly single-vehicle crashes on private roads, two vehicle crashes in parking facilities, or collisions with pedestrians in driveways. In addition, there are non-traffic incidents such as a vehicle falling on a person underneath or an unintentional carbon monoxide poisoning inside the vehicle. Non-traffic crash data is obtained through NHTSA's CISS, SCI, Crash Reporting Sampling System (CRSS), and FARS.

For the standard investigation-based crash data studies acquisition process, once a crash has been selected for investigation, crash technicians locate, visit, measure, and photograph the crash scene; locate, visit, inspect, and photograph involved vehicle(s); conduct a telephone or personal interview with the involved individuals or a surrogate (another person who can provide occupant or crash information, such as parents for a minor or parent or spouse for a deceased individual); and obtain and record crash injury information received from various medical data sources. These data are used to describe and analyze circumstances, mechanisms, and consequences of a cross section of towed, light passenger motor vehicle crashes in the United States. The collection of interview data aids in this effort.

For the special studies, the data is typically gathered following similar procedures, but is targeted to a specific issue (e.g., child occupant protection, crash causation factors) as opposed to an entire investigation. Special Studies investigations also typically only involve obtaining information from law enforcement, who provide access to and a copy of the crash report where the data is not electronic. They do not involve interviewing people involved in crashes, obtaining medical records or inspecting the vehicles. Each special study has specific requirements (i.e., types of crashes and/or data collected); however, the gathering of crash reports for these studies is similar to the gathering of crash reports in the CISS and SCI programs.

Description of the Need for the Information and Proposed Use of the Information: NHTSA investigates real-world crashes and collects detailed crash data through CISS, SCI, and Special Studies data collection programs to identify the primary factors related to the source of crashes and their injury outcomes. These detailed factors are utilized to develop and evaluate

effective safety countermeasures including the establishment and enforcement of motor vehicle regulations that reduce the severity of injury and property damage caused by motor vehicle crashes. The data collected also give motor vehicle researchers an opportunity to specify areas in which improvements may be possible, design countermeasure programs, and evaluate the effects of existing and proposed safety measures.

Burden to Respondents: NHTSA has provided a description of the affected public, estimated number of respondents, description of frequency, and estimates of the total burden hours and costs for each of the three Investigation-Based Crash Data Acquisition Systems (CISS, SCI, and Special Studies) below. In aggregate, NHTSA estimates that the total annual burden is 17,521 hours and the total annual cost of \$0.

Program: CISS.

Affected Public: People involved in select motor vehicle crashes, law enforcement jurisdictions that provide access to and a copy of the crash report where the data is not electronic; hospitals that provide a copy of the injured occupant's medical treatment of injuries; and tow or salvage lot facilities that provide access to the storage facility to inspect the vehicle.

Estimated Number of Respondents: 37,175.

Frequency: On Occasion.

Estimated Total Annual Burden Hours: 17,245 hours (10,950 + 1,071 + 388 + 3,627 + 1,209).

The CISS crash data acquisition system includes 5 information collections. The first information collection covers the collection of information from individuals involved in crashes via interview. The estimated number of interview respondents is obtained by multiplying the approximate number of crashes investigated each year by the average number of interviews per crash. Based on existing data, each CISS crash involves an average of approximately 2.25 individuals. NHTSA estimates that CISS conducts investigations on 14,600 crashes per year. Therefore, NHTSA estimates that there will be 32,850 respondents per year (14,600 crashes × 2.25 respondents per crash).

The respondents are contacted only once; however, in rare circumstances follow-up questions may be needed to clarify data. The interview requires approximately 20 minutes of a respondent's time on average. CISS conducts interviews for approximately 14,600 crashes per year, which NHTSA estimates takes about 45 minutes per

crash (2.25 respondents × 20 minutes). Therefore, the estimated total annual burden hours for the collection of information from individuals involved in crashes for CISS is 10,950 hours ((14,600 crashes × 45 minutes) ÷ 60 minutes/hour).

In addition to interviews, crash technicians and investigators must obtain official records to initiate and complete the cases. These records include police crash reports and medical records. The second information collection under CISS is for the collection of crash records from sampled police jurisdictions. NHTSA estimates that there are 412 sample police jurisdictions annually. To estimate the burden to sampled police jurisdictions, NHTSA multiplied the average number of visits per year by the average burden per visit and the number of police jurisdictions. On average, each of the 412 sampled police jurisdictions are queried weekly (or 52 times per year) and each query is estimated to take 3 minutes. Accordingly, NHTSA estimates the total annual burden for sampled police jurisdictions to be 2.6 hours per respondent (3 minutes × 52 visits) and 1,071 hours for all respondents (2.6 hours × 412 police jurisdictions = 1,071.2 hours).

The third information collection under CISS is for the collection of crash records from non-sampled police jurisdictions. Based on existing CISS data, there are 775 non-sampled jurisdictions annually. To estimate the burden to non-sample police jurisdictions, NHTSA multiplied the average number of visits per year by the average burden per visit and the number of non-sampled police jurisdictions. On average, each of the 775 non-sampled police jurisdictions are visited twice annually and each query is estimated to take 15 minutes. Accordingly, NHTSA estimates the total burden for non-sampled police jurisdictions to be 30 minutes per respondent (15 minutes × 2 visits) and 388 hours for all respondents ((30 minutes × 775 non-sampled police jurisdictions) ÷ 60 minutes/hour) = 388 hours).

The fourth information collection under CISS is for the collection of medical records from hospitals. Based on existing data, CISS collects an average of 21,763 records each year from an average of 628 hospitals. NHTSA estimates that a hospital spends 10 minutes for each record requested. Accordingly, NHTSA estimates the total annual burden to be 3,627 hours ((21,763 records × 10 minutes) ÷ 60 minutes/hour) and estimates that each hospital will, on average, spend 5.78 hours providing the requested

information each year (3,627 hours + 628 hospitals).

The fifth information collection under CISS is for the collection from tow yards necessary to gain access to and locate a vehicle that was involved in a crash. Typically, a tow facility operator just needs to give the crash technician permission to enter the yard to inspect the vehicle and involves approximately 5 minutes of staff time. CISS data shows an average of 14,508 visits to tow facilities per year, and NHTSA estimates 2,510 tow facilities will be visited annually. Accordingly, NHTSA estimates the total annual burden to be 1,209 hours ((14,508 visits × 5 minutes) ÷ 60 minutes/hour) and estimates that each tow facility will, on average, spend 28.91 minutes providing the requested information each year ((1,209 hours × 60 minutes) ÷ 2,510 facilities).

Accordingly, NHTSA estimates that the total burden associated with the CISS data acquisition system is 17,245 hours (10,950 + 1,071 + 388 + 3,627 + 1,209).

Estimated Total Annual Burden Cost: \$0.

There are no capital, start-up, or annual operation and maintenance costs involved in this collection of information. The respondents would not incur any reporting costs from the information collection beyond the opportunity or labor costs associated with the burden hours. The respondents also would not incur any recordkeeping burden or recordkeeping costs from the information collection.

Program: Special Crash Investigation (SCI).

Affected Public: People involved in select motor vehicle crashes, law enforcement jurisdictions that provide access to and a copy of the crash report where the data is not electronic; hospitals that provide a copy of the injured occupant's medical treatment of injuries; and tow or salvage lot facilities that provide access to the storage facility to inspect the vehicle.

Estimated Number of Respondents: 500.

Frequency: On occasion (typically once per year).

Estimated Total Annual Burden Hours: 109 hours (67 + 17 + 17 + 8).

The SCI crash data acquisition system includes 4 information collections. The first information collection covers the collection of information from individuals involved in crashes via interview. The estimated number of interview respondents is obtained by multiplying the approximate number of crashes investigated each year by the average number of interviews per crash.

Based on existing data, each SCI crash involves an average of approximately 2 individuals. NHTSA estimates that SCI conducts investigations on approximately 100 crashes per year. Therefore, NHTSA estimates that there will be 200 respondents per year (100 crashes × 2 respondents per crash).

The respondents are contacted only once; however, in rare circumstances follow-up questions may be needed to clarify data. The interview requires approximately 20 minutes of a respondent's time on average. SCI conducts interviews for approximately 100 crashes per year, which NHTSA estimates takes about 40 minutes per crash (2 respondents × 20 minutes). Therefore, the estimated total annual burden hours for the collection of information from individuals involved in crashes for SCI is approximately 67 hours ((100 crashes × 40 minutes) ÷ 60 minutes/hour = 66.67).

In addition to interviews, crash technicians and investigators must obtain official records to initiate and complete the cases. These records include police crash reports and medical records. The second information collection under SCI is for the collection of crash records from police jurisdictions. The SCI investigators contact an estimated 100 police jurisdictions once per year and require approximately 10 minutes of staff time per police jurisdiction. To estimate the burden to these police jurisdictions, NHTSA multiplied the average number of visits per year by the average burden per visit and the number of police jurisdictions. Accordingly, NHTSA estimates the total annual burden for police jurisdictions to be 10 minutes per respondent (10 minutes × 1 query per year) and 17 hours for all respondents ((10 minutes × 100 police jurisdictions) ÷ 60 minutes/hour = 16.67 hours).

The third information collection under SCI is for the collection of medical records from hospitals. Based on existing data, SCI collects an average

of 100 records each year from 100 hospitals (1 request per hospital per year). NHTSA estimates that a hospital spends 10 minutes for each record requested. Accordingly, NHTSA estimates the total annual burden to be 17 hours ((100 records × 10 minutes) ÷ 60 minutes/hour = 16.67 hours) and estimates that each hospital will, on average, spend 10 minutes providing the requested information each year (10 minutes × 1 record request per year).

The fourth information collection under SCI is for the collection from tow yards necessary to gain access to and locate a vehicle that was involved in a crash. Typically, a tow facility operator just needs to give the crash technician permission to enter the yard to inspect the vehicle and involves approximately 5 minutes of staff time. SCI conducts approximately 100 visits to tow facilities per year, and NHTSA estimates that 100 tow facilities will be visited annually (1 request per facility per year). Accordingly, NHTSA estimates the total annual burden to be 8 hours ((100 visits × 5 minutes) ÷ 60 minutes/hour = 8.33 hours) and estimates that each tow facility will, on average, spend 5 minutes providing the requested information each year.

Accordingly, NHTSA estimates that the total burden associated with the SCI data acquisition system is 109 hours (67 + 17 + 17 + 8).

Estimated Total Annual Burden Cost: \$0.

There are no capital, start-up, or annual operation and maintenance costs involved in this collection of information. The respondents would not incur any reporting costs from the information collection beyond the opportunity or labor costs associated with the burden hours. The respondents also would not incur any recordkeeping burden or recordkeeping costs from the information collection.

Special Studies

Affected Public: Law enforcement jurisdictions that provide access to and

a copy of the crash report where the data is not electronic.

Estimated Number of Respondents: 1,000.

Frequency: On occasion (typically once per year).

Estimated Total Annual Burden Hours: 167 hours.

There is only one information collection for Special Studies in this ICR. This ICR only covers special studies involving remote-level investigations.¹ Accordingly, these remote-level investigations do not involve interviews of individuals involved in crashes, collection of medical records from hospitals, or visits to tow facilities. Instead, these special studies only involve the collection of information from police jurisdictions.

NHTSA estimates that the special studies will involve, on average, 1,000 police jurisdictions each year and require approximately 10 minutes of staff time per police jurisdiction. The total annual hour burden on jurisdictions for special studies information is estimated to be 167 hours (1 visit × 10 minutes × 1,000 jurisdictions ÷ 60 minutes/hour = 166.67).

Estimated Total Annual Burden Cost: \$0.

There are no capital, start-up, or annual operation and maintenance costs involved in this collection of information. The respondents would not incur any reporting costs from the information collection beyond the labor costs associated with the burden hours. The respondents also would not incur any recordkeeping burden or recordkeeping costs from the information collection.

Estimated Total Annual Burden Hours All Programs: 17,521 hours.

The total estimated annual burden hours to all respondents for this ICR is 17,521 hours. The table below provides a summary of the estimated annual burden hours.

TABLE 1—SUMMARY OF BURDEN HOUR ESTIMATES

Information collection title	Number of respondents	Number of responses (per respondent)	Burden per response (minutes)	Burden per respondent	Total annual burden (hours)
CISS: Interviews with Individuals Involved in Crashes	32,850	32,850 (1)	20	20 minutes	10,950
CISS: Collection of Police Records from Sampled Jurisdictions ...	412	21,424 (52)	3	156 minutes (2.6 hours)	1,071
CISS: Collection of Police Records from Non-Sampled Jurisdictions.	775	1,550 (2)	15	30 minutes	388
CISS: Collection of Medical Records	628	21,763 (34.665)	10	5.78 hours	3,627
CISS: Access to Tow Yards	2,510	14,508 (5.78)	5	28.9 minutes	1,209
SCI: Interviews with Individuals Involved in Crashes	200	200 (1)	20	20 minutes	67
SCI: Collection of Police Records	100	100 (1)	10	10 minutes	17
SCI: Collection of Medical Records	100	100 (1)	10	10 minutes	17

¹ If NHTSA intends to conduct a special study that is not remote, it will seek separate clearance.

TABLE 1—SUMMARY OF BURDEN HOUR ESTIMATES—Continued

Information collection title	Number of respondents	Number of responses (per respondent)	Burden per response (minutes)	Burden per respondent	Total annual burden (hours)
SCI: Access to Tow Yards	100	100 (1)	5	5 minutes	8
Special Studies: Collection of Police Records	1,000	1,000 (1)	10	10 minutes	167
Total	38,675	17,521

Estimated Total Annual Burden Cost All Programs: \$0.

There is no capital, start-up, or annual operation and maintenance costs involved in this collection of information. The respondents would not incur any reporting costs from the information collection beyond the labor costs associated with the burden hours. The respondents also would not incur any recordkeeping burden or recordkeeping costs from the information collection.

Public Comments Invited: You are asked to comment on any aspects of this information collection, including (a) whether the proposed collection of information is necessary for the proper performance of the functions of the Department, including whether the information will have practical utility; (b) the accuracy of the Department’s estimate of the burden of the proposed information collection; (c) ways to enhance the quality, utility and clarity of the information to be collected; and (d) ways to minimize the burden of the

collection of information on respondents, including the use of automated collection techniques or other forms of information technology.
Authority: The Paperwork Reduction Act of 1995; 44 U.S.C. chapter 35, as amended; 49 CFR 1.49; and DOT Order 1351.29.

Chou-Lin Chen,
Associate Administrator, National Center for Statistics and Analysis.
 [FR Doc. 2025-06118 Filed 4-9-25; 8:45 am]
BILLING CODE 4910-59-P



FEDERAL REGISTER

Vol. 90

Thursday,

No. 68

April 10, 2025

Part II

The President

Notice of April 8, 2025—Continuation of the National Emergency With Respect to Somalia

Presidential Documents

Title 3—**Notice of April 8, 2025****The President****Continuation of the National Emergency With Respect to Somalia**

On April 12, 2010, by Executive Order 13536, the President declared a national emergency pursuant to the International Emergency Economic Powers Act (50 U.S.C. 1701 *et seq.*) to deal with the unusual and extraordinary threat to the national security and foreign policy of the United States constituted by the deterioration of the security situation and the persistence of violence in Somalia; acts of piracy and armed robbery at sea off the coast of Somalia, which have been the subject of United Nations Security Council resolutions; and violations of the arms embargo imposed by the United Nations Security Council.

On July 20, 2012, the President issued Executive Order 13620 to take additional steps to deal with the national emergency declared in Executive Order 13536 in view of United Nations Security Council Resolution 2036 of February 22, 2012, and Resolution 2002 of July 29, 2011, and to address: exports of charcoal from Somalia, which generate significant revenue for al-Shabaab; the misappropriation of Somali public assets; and certain acts of violence committed against civilians in Somalia, all of which contribute to the deterioration of the security situation and the persistence of violence in Somalia.

The situation with respect to Somalia continues to pose an unusual and extraordinary threat to the national security and foreign policy of the United States. For this reason, the national emergency declared on April 12, 2010, and the measures adopted on that date and on July 20, 2012, to deal with that threat, must continue in effect beyond April 12, 2025. Therefore, in accordance with section 202(d) of the National Emergencies Act (50 U.S.C. 1622(d)), I am continuing for 1 year the national emergency declared in Executive Order 13536.

This notice shall be published in the *Federal Register* and transmitted to the Congress.

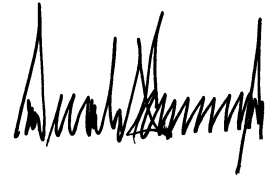
A handwritten signature in black ink, appearing to be a stylized name, possibly 'Donald Trump', written in a cursive script.

THE WHITE HOUSE,
April 8, 2025.

[FR Doc. 2025-06289
Filed 4-9-25; 11:15 am]
Billing code 3395-F4-P

Reader Aids

Federal Register

Vol. 90, No. 68

Thursday, April 10, 2025

CUSTOMER SERVICE AND INFORMATION

Federal Register/Code of Federal Regulations	
General Information, indexes and other finding aids	202-741-6000
Laws	741-6000
Presidential Documents	
Executive orders and proclamations	741-6000
The United States Government Manual	741-6000
Other Services	
Electronic and on-line services (voice)	741-6020
Privacy Act Compilation	741-6050

ELECTRONIC RESEARCH

World Wide Web

Full text of the daily Federal Register, CFR and other publications is located at: www.govinfo.gov.

Federal Register information and research tools, including Public Inspection List and electronic text are located at: www.federalregister.gov.

E-mail

FEDREGTOC (Daily Federal Register Table of Contents Electronic Mailing List) is an open e-mail service that provides subscribers with a digital form of the Federal Register Table of Contents. The digital form of the Federal Register Table of Contents includes HTML and PDF links to the full text of each document.

To join or leave, go to <https://public.govdelivery.com/accounts/USGPOOFR/subscriber/new>, enter your email address, then follow the instructions to join, leave, or manage your subscription.

PENS (Public Law Electronic Notification Service) is an e-mail service that notifies subscribers of recently enacted laws.

To subscribe, go to <http://listserv.gsa.gov/archives/publaws-l.html> and select *Join or leave the list (or change settings)*; then follow the instructions.

FEDREGTOC and **PENS** are mailing lists only. We cannot respond to specific inquiries.

Reference questions. Send questions and comments about the Federal Register system to: fedreg.info@nara.gov

The Federal Register staff cannot interpret specific documents or regulations.

FEDERAL REGISTER PAGES AND DATE, APRIL

14329-14410.....	1
14411-14548.....	2
14549-14714.....	3
14715-14896.....	4
14897-15110.....	7
15111-15200.....	8
15201-15300.....	9
15301-15392.....	10

CFR PARTS AFFECTED DURING APRIL

At the end of each month the Office of the Federal Register publishes separately a List of CFR Sections Affected (LSA), which lists parts and sections affected by documents published since the revision date of each title.

3 CFR	141.....	14738
Proclamations:		
10908.....	14705	
10909.....	14897	
10910.....	15201	
10911.....	15203	
10912.....	15205	
10913.....	15207	
Executive Orders:		
12171 (amended by EO 14251).....	14553	
14250.....	14549	
14251.....	14553	
14252.....	14559	
14253.....	14563	
14254.....	14699	
14255.....	14701	
14256.....	14899	
14257.....	15041	
14258.....	15209	
Administrative Orders:		
Notices:		
Notice of March 28, 2025.....	14329	
Notice of April 8, 2025.....	15391	
10 CFR		
30.....	15211	
40.....	15211	
60.....	15211	
61.....	15211	
63.....	15211	
70.....	15211	
72.....	15211	
590.....	14411	
Proposed Rules:		
72.....	14917	
12 CFR		
1610.....	14412	
14 CFR		
39.....	14331, 14561, 14569, 14571, 14574, 14715, 14717, 14719, 14723, 14903, 15111, 15114, 15116, 15301, 15304, 15306, 15310	
71.....	14334, 15312, 15313, 15314, 15315	
97.....	14334, 14336, 14576, 14578	
Proposed Rules:		
Ch. I.....	14595	
39.....	14343, 14346, 14589, 14920, 14922, 14924, 14927, 14929, 15318, 15321	
47.....	14592	
71.....	14349, 14593, 15124, 15125	
Ch. II.....	14595	
Ch. III.....	14595	
16 CFR		
Proposed Rules:		
Ch. II.....	15324	
23 CFR		
Proposed Rules:		
Ch. I.....	14595	
Ch. II.....	14595	
Ch. III.....	14595	
27 CFR		
Proposed Rules:		
4.....	14932	
5.....	14932	
7.....	14932	
24.....	14932	
25.....	14932	
27.....	14932	
29 CFR		
4044.....	14579, 15211	
33 CFR		
100.....	14338	
117.....	14726, 14728, 14905	
165.....	14581	
Proposed Rules:		
Ch. IV.....	14595	
100.....	14739, 14933	
165.....	15127	
34 CFR		
Proposed Rules:		
Ch. VI.....	14741	
39 CFR		
111.....	14338	
40 CFR		
52.....	14341, 14414, 14583, 14730, 15119	
180.....	14907, 14911	
751.....	14415	
Proposed Rules:		
52.....	14426, 14935, 14939, 15213	
81.....	14939	
174.....	14954	
180.....	14954	
46 CFR		
Proposed Rules:		
Ch. II.....	14595	
47 CFR		
73.....	14736, 15212, 15316	
Proposed Rules:		
54.....	14429, 15129	
48 CFR		
501.....	15212	

552.....15212	49 CFR	Ch. III.....14595	648.....14915
Proposed Rules:	Proposed Rules:	Ch. V.....14595	679.....14586
Ch. 12.....14595	Subtitle A.....14595	Ch. VI.....14595	Proposed Rules:
	Subtitle B.....14595	50 CFR	300.....15129
	Ch. I.....14595	92.....14417	648.....14350, 14597
	Ch. II.....14595	300.....14422	679.....14771

LIST OF PUBLIC LAWS

Note: No public bills which have become law were received by the Office of the Federal Register for inclusion

in today's **List of Public Laws**.

Last List March 20, 2025

Public Laws Electronic Notification Service (PENS)

PENS is a free email notification service of newly

enacted public laws. To subscribe, go to https://portalguard.gsa.gov/__layouts/PG/register.aspx.

Note: This service is strictly for email notification of new laws. The text of laws is not available through this service. **PENS** cannot respond to specific inquiries sent to this address.